

NOTES

1. ALL DIMENSIONS IN INCHES
[] DIMENSIONS IN MILLIMETERS
2. TOLERANCES ON
2 PL. DECIMAL = ±0.03
3 PL. DECIMAL = ±0.005
ANGLES = ±0°-30'
UNLESS OTHERWISE SPECIFIED.
3. MATERIAL: 1/16" THICK SILICONE,
50-60 DUROMETER.

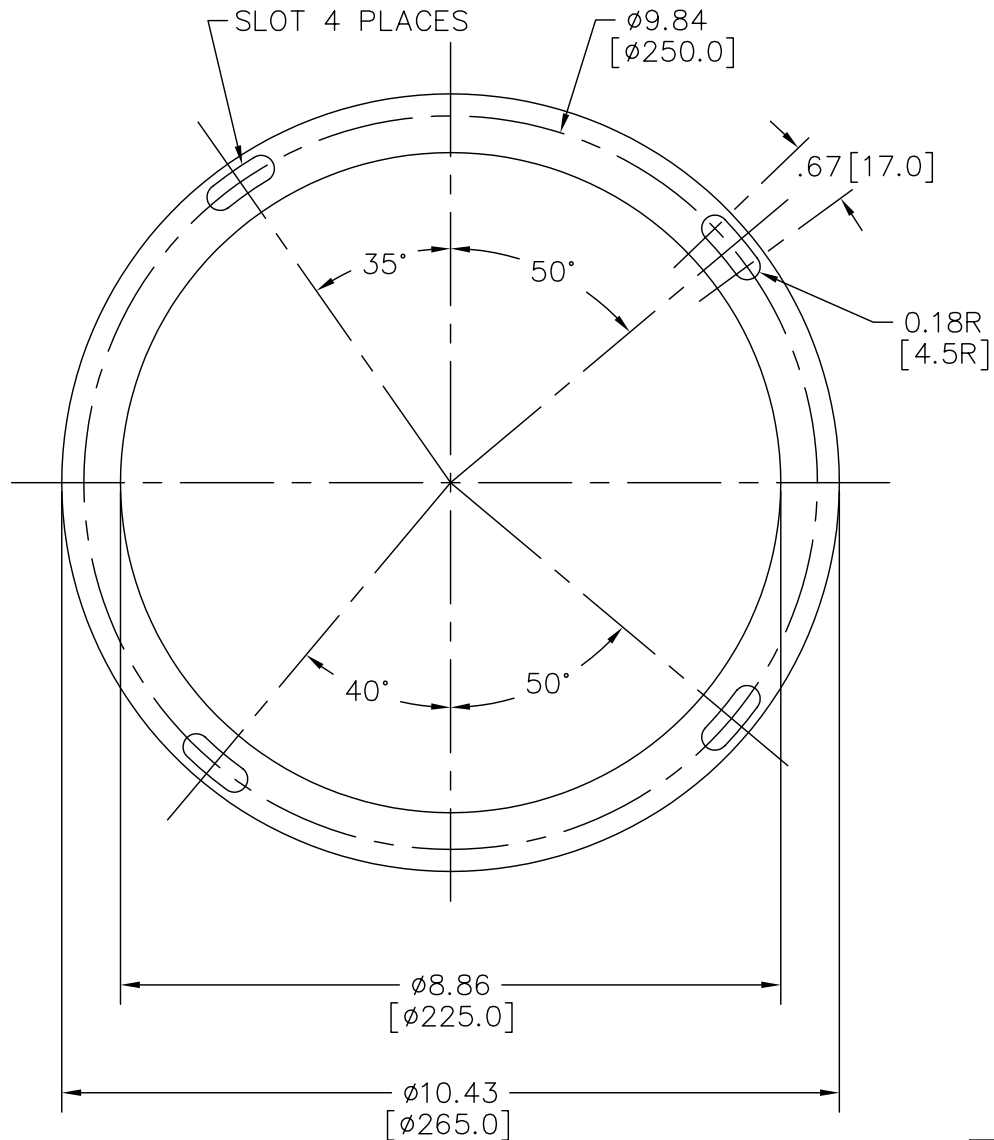

USE DIMENSIONS ONLY - DO NOT SCALE		0	FOR CONSTRUCTION	MAM	RDC	MAR 30/05
DIMENSIONS ARE IN INCHES		Rev.	Revision / EON Description	Drawn	Appr.	Date
Third Angle Projection	Product Group	Tolerance Unless Otherwise Noted: UOS		Scale:	Size:	
	MASS DYNAMICS	1 Place Decimal ± 0.03 Angles: ± 0.5°		1:1	C	
	Date:	30/03/05				
	Drawn:	M. MORRISSEY		TITLE: GASKET,FRNT,SIDEMOUNT 1/16" THK FABRICATION DETAIL E-40 FLOWMETERS		
	Checked:	J. MARETT				
	Approved:	R. CROSS				
	Location:	PETERBOROUGH				
FOR INTERNAL USE ONLY	SIEMENS MILLTRONICS PROCESS INSTRUMENTS INC. Peterborough, Ontario, Canada	DRAWING No: 22600022		Rev:	0	
	File No. 2260002200	Plot at: 1=1	Sheet 1	Of 1		