

Instruction Manual • September 2003



**milltronics**

MILLFLO

**SIEMENS**

## Safety Guidelines

Warning notices must be observed to ensure personal safety as well as that of others, and to protect the product and the connected equipment. These warning notices are accompanied by a clarification of the level of caution to be observed.

## Qualified Personnel

This device/system may only be set up and operated in conjunction with this manual. Qualified personnel are only authorized to install and operate this equipment in accordance with established safety practices and standards.

**Warning:** This product can only function properly and safely if it is correctly transported, stored, installed, set up, operated, and maintained.

**Note:** Always use product in accordance with specifications.

**Copyright Siemens Milltronics Process Instruments Inc. 2003. All Rights Reserved**

**Disclaimer of Liability**

This document is available in bound version and in electronic version. We encourage users to purchase authorized bound manuals, or to view electronic versions as designed and authored by Siemens Milltronics Process Instruments Inc. Siemens Milltronics Process Instruments Inc. will not be responsible for the contents of partial or whole reproductions of either bound or electronic versions.

While we have verified the contents of this manual for agreement with the instrumentation described, variations remain possible. Thus we cannot guarantee full agreement. The contents of this manual are regularly reviewed and corrections are included in subsequent editions. We welcome all suggestions for improvement.

Technical data subject to change.

MILLTRONICS® is a registered trademark of Siemens Milltronics Process Instruments Inc.

**Contact SMPI Technical Publications at the following address:**

Technical Publications  
Siemens Milltronics Process Instruments Inc.  
1954 Technology Drive, P.O. Box 4225  
Peterborough, Ontario, Canada, K9J 7B1  
Email: [techpubs@siemens-milltronics.com](mailto:techpubs@siemens-milltronics.com)

For the library of SMPI instruction manuals, visit our Web site: [www.siemens-milltronics.com](http://www.siemens-milltronics.com)

# Table of Contents

---

<b>Milltronics Millflo Solids Flowmeter .....</b>	<b>1</b>
<b>The Manual .....</b>	<b>1</b>
<b>Specifications .....</b>	<b>2</b>
<b>Operation .....</b>	<b>4</b>
Components .....	4
Horizontal Sensing Plate .....	4
Negative Displacement .....	5
<b>Installation .....</b>	<b>6</b>
Preparation .....	6
Welding .....	6
Load Cell Handling .....	6
Disassembly .....	7
Installation of Shipping Stop .....	7
Installation .....	8
Millflo Outline and Dimensions .....	9
Millflo Wiring .....	10
Calibration .....	11
<b>Applications .....</b>	<b>13</b>
Material Feed .....	13
Flowmeter In-Feed Chutes .....	15
<b>Maintenance .....</b>	<b>18</b>
Periodic Recalibration .....	18
Checks .....	18
Spare Parts .....	18



# Milltronics Millflo Solids Flowmeter

---

The Milltronics Millflo solids flowmeter is a low to medium-capacity flowmeter for various product sizes, densities, and fluidities in restricted spaces. This low-cost compact unit improves processing, increases operating efficiency, and helps provide significant cost savings.

Operating with a microprocessor-based integrator package, the Millflo provides a display of flowrate, totalized flow, and alarms. Outputs are 0/4 to 20 mA proportional to rate and open collector output for remote totalization.

Dry bulk solids enter the flowguide producing a mechanical deflections as they strike the flowmeter sensing plate before continuing through the process unhindered. A strain gauge loadcell converts the horizontal force of the deflection into an electrical signal. The integrator processes this into a display of flowrate and integrated total weight. The process is immune to the effect of product buildup as only horizontal force is measured.

The Millflo features easy installation into standard pipe sizes, simple operation, and fast and accurate flow response.

The Millflo is an accurate and repeatable force sensor and its performance depends on the consistency of the material flow into the flowmeter and the quality of the installation.

## The Manual

---

This manual covers the installation, operation, and maintenance of the Milltronics Millflo solids flowmeter.

Please refer to this manual for proper installation and operation of any component of the system to which the Millflo is applied. Adhering to the installation and operating procedures will ensure a quick and trouble free installation and allows for the maximum accuracy and reliability of your system. Because the Millflo is used in conjunction with an integrator, refer to the integrator's manual also.

If you have any questions, comments, or suggestions about the manual's contents, please email us at [techpubs@siemens-milltronics.com](mailto:techpubs@siemens-milltronics.com).

For the complete library of Siemens Milltronics manuals, go to [www.siemens-milltronics.com](http://www.siemens-milltronics.com).

# Specifications

---

## Nominal Sizes

- 100 mm (4"), 150 mm (6"), 200 mm (8"), 250 mm (10"), 300 mm (12")

## Flow Rate

- 1 t/h to 230 t/h (1 STPH to 250 STPH) dependent upon range (see page 3) and product bulk density

## Product

- fine powder to 13 mm (1/2 inch) (see page 3)

## Operating Temperature

- -40 to 65 °C (-40 to 150 °F)

## Repeatability

- $\pm 0.2\%$

## Accuracy

- $\pm 1\%$  of full scale

## Construction

- assembly:
  - all welded housing and flowguide
- material:
  - mild steel, painted
  - optional: 304 (1.4301) or 316 (1.4404) stainless steel
- gasketing:
- silicone rubber
- sensing plate:
  - 304 (1.4301) stainless steel
  - optional:
    - 316 (1.4404) stainless steel
    - wear resistant coatings
    - low friction coating

## Load Cell

- stainless steel parallelogram
- temperature:
  - -40 to 85 °C (-40 to 185 °F) maximum range
  - 0 to 65 °C (32 to 150 °F) internally compensated
- output:
  - 2 mV / V excitation at rated load cell capacity

## Approvals

- CE

## Weight

- see page 3

## Flowmeter Range

- the following ranges and load cell sizes have been specified

Size (inlet)	Min. Flow	Max. Flow	Particle Size	Load Cell Size	Weight
4"	0 - 1 STPH 0 - 1 t/h	0 - 15 STPH 0 - 14 t/h	6 mm (1/4")	2 or 5 lb.	20 kg (45 lb.)
6"	0 - 4.4 STPH 0 - 4t/h	0 - 38 STPH 0 - 35t/h	10 mm (3/8")	5 or 10 lb.	32 kg (70 lb.)
8"	0 - 20 STPH 0 - 18 t/h	0 - 88 STPH 0 - 80 t/h	10 mm (3/8")	10 or 20 lb.	90 kg (200 lb.)
10"	0 - 50 STPH 0 - 45 t/h	0 - 14 STPH 0 - 13 t/h	13 mm (1/2")	20 or 50 lb.	113 kg (250 lb.)
12"	0 - 100 STPH 0 - 90 t/h	0 - 250 STPH 0 - 230 t/h	13 mm (1/2")	100 lb.	136 kg (300 lb.)

Maximum flowrates are based on material densities of 1.6 t /m<sup>3</sup> (100 lb./ft<sup>3</sup>).

# Operation

## Components

The Millflo reacts to the horizontal component of force created by the impact of material on the sensing plate. The Millflo consists of two physical components:

- the housing which includes the flowguide and the outlet. It supports the sensing assembly and guides the material flow.
- the sensing assembly, which includes the sensing plate and the load cell.

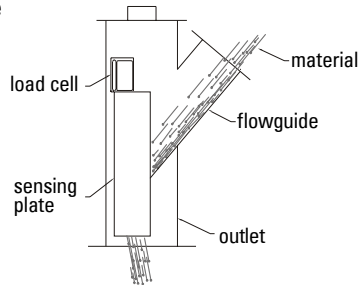

## Horizontal Sensing Plate

The material travels down the flowguide, striking the sensing plate and discharging through the outlet. The force exerted on the sensing plate has both a vertical and horizontal component. The design of the load cell is such that it reacts to the horizontal component only; the vertical component is ignored.

The sensing plate is displaced proportionally to the material flow and is not susceptible to material build up, so long as it does not bridge across to the housing. Positive displacement of the load cell is limited by the positive stop incorporated in the design of the load cell.

The displacement of the load cell is sensed by its strain gauges. These convert the excitation signal from the electronic integrator to produce a signal proportional to material flow.

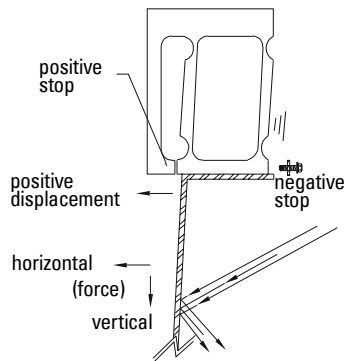



# Negative Displacement

A negative stop protects the load cell against excessive negative displacement which could functionally destroy it. The negative stop is factory set so that the output signal is limited to -20 mV when the load cell is forced to travel in the negative direction.

Under no-flow conditions, the load cell/sensing plate assembly is at rest at static zero. Under this condition, the negative stop should not contact the load cell, and the output signal from the load cell will be approximately -5 to 0 mV DC.

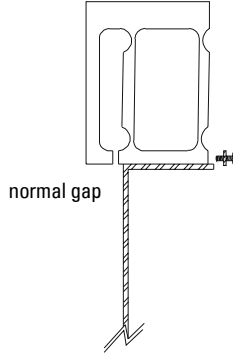
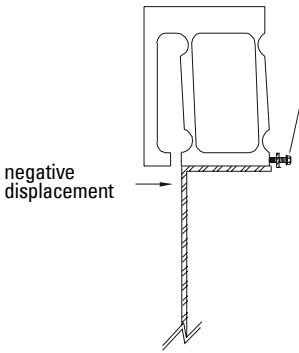

# Installation

## Preparation

Prepare the site in accordance to the Siemens Milltronics drawing(s) provided. If no drawings were provided or if there is confusion or doubt as to the Milltronics Millflo's installation, please consult your Siemens Milltronics representative.

When unpacking the Millflo, avoid subjecting the unit to mechanical shock. Excessive mechanical shock can cause damage to the housing or load cell/sensing plate assembly. The Millflo is generally shipped assembled with the sensing plate arrested to prevent damage to the load cell.

The Millflo should be visually inspected for shipping damage. If damage is suspected, contact your Siemens Milltronics representative and the shipping carrier.

When handling the Millflo, ensure the shipping stop is in place to secure the sensing plate. Never subject the Millflo to shock by hitting it when trying to position it.

## Welding

**WARNING:** Use extreme caution when arc welding in the area of the flowmeter to ensure that no welding current flows through the flowmeter, risking destruction of the load cell.

Remove the sensing plate and load cell before welding.

## Load Cell Handling

The load cell tolerates very little negative displacement, or it may be functionally destroyed. When handling the load cell, care must be taken not to force the gap open.

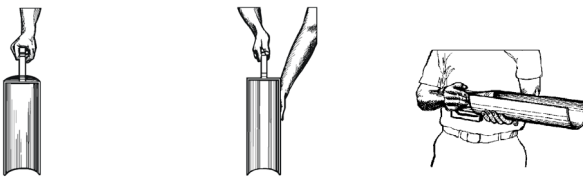

**SUPPORT LOAD CELL THROUGHOUT HANDLING IN NON-VERTICAL POSITIONS.**

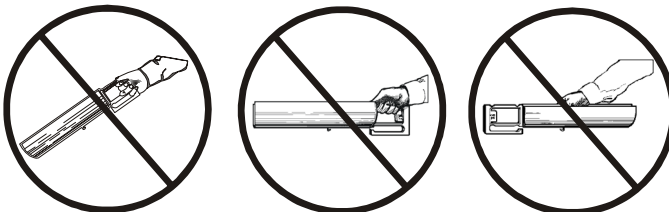

**IMPROPER HANDLING MAY FUNCTIONALLY DESTROY LOAD CELL**

# Disassembly

Remove the load cell/sensing plate assembly from the housing prior to installation.

1. Remove the access cover, loosen the shipping rod nuts as shown, and then remove. Retain calibration weight cable for use in the calibration procedure.
2. Secure access door.
3. Remove and hold top cover/ junction box assembly. Avoid applying stress to the load cell cable connected through the cover to the junction box.
4. Hold the load cell by the upper cross piece. (See *Load Cell Handling* on page 6).
5. Remove load cell mounting screws (2 places), and then lift load cell/sensing plate assembly up and out of the housing, keeping the sensing assembly vertical.
6. Set the assemblies aside in a safe place.

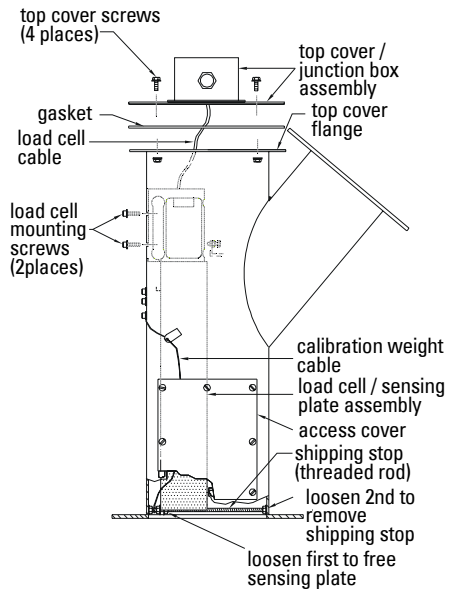

**IMPORTANT:** While transporting, support the load cell / sensing plate assembly as shown in *Load Cell Handling* on page 6.

## Installation of Shipping Stop

Whenever the unit is to be moved, the shipping stop should be reinstalled to prevent damage to the load cell/sensing plate assembly.

1. With the sensing plate resting in its static position, insert threaded rod as shown.
2. Tighten the two end nuts against the housing to secure the rod in place.
3. Turn the two opposing sensing plate locking nuts toward the sensing plate, maintaining the sensing plate in its static position. Tighten nuts to secure sensing plate.

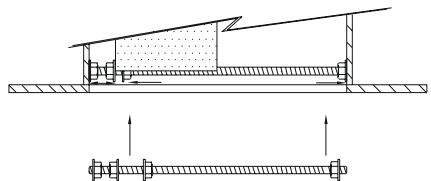

# Installation

1. Set the Millflo housing in place ensuring that the flowguide and outlet gaskets are correctly located.
2. The housing must be vertical within  $1^\circ$  in two planes  $90^\circ$  apart.
3. Bolt the flowguide and outlet flanges to the process piping.
4. If the load cell/sensing plate assembly was not removed prior to beginning the installation procedure, the shipping stop must be removed. Refer to *Disassembly* on page 7 to remove the shipping stop.

If the load cell/sensing plate assembly was removed, reverse the disassembly procedure to reassemble the load cell/sensing assembly into the housing and to replace the cover/junction box assembly on to the top access flange. Do not reinstall the shipping stop. Exercise caution while handling the load cell/sensing plate assembly. Refer to the diagrams in the *Load Cell Handling* section on page 6.

5. Wire the unit in accordance with Siemens Milltronics supplied connection diagrams or as described in the integrator instruction manual.

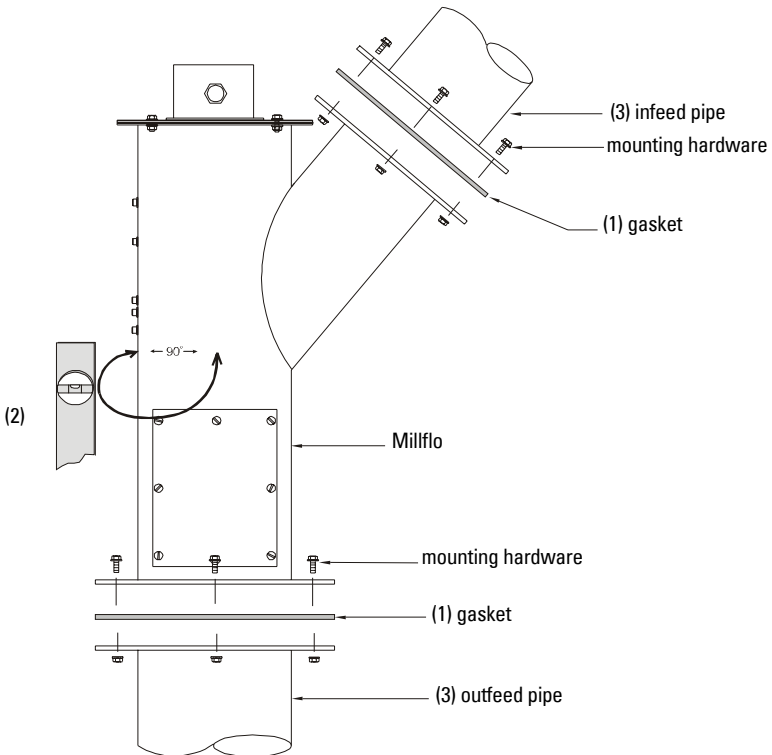

**NOTE: All items other than Millflo supplied by customer**

# Milflo Outline and Dimensions

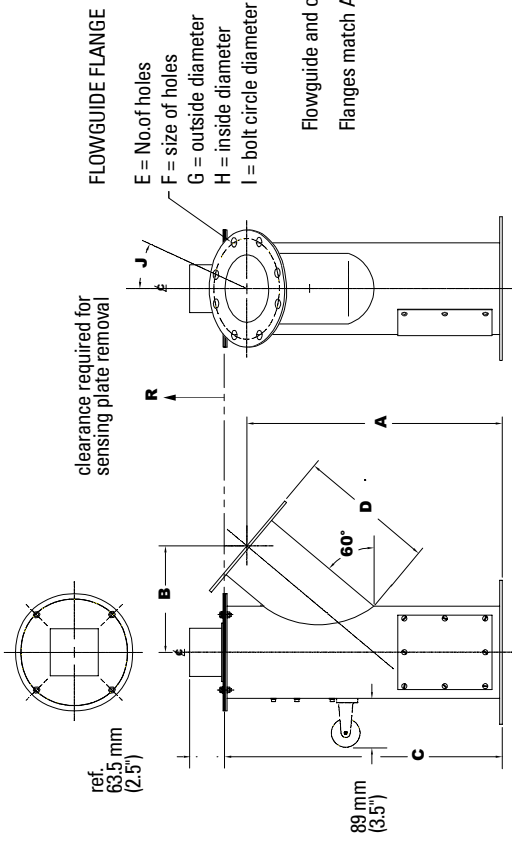

## FLOWGUIDE FLANGE

- E = No. of holes
- F = size of holes
- G = outside diameter
- H = inside diameter
- I = bolt circle diameter

Flowguide and outlet: DIN versions are available.  
Flanges match ANSI patterns

## OUTLET FLANGE

- K = No. of holes
- L = size of holes
- M = outside diameter
- N = inside diameter
- P = bolt circle diameter

Size	Milflo Dimensions										Flange (Infeed)					Flange (Outfeed)				
	A	B	C	D	E	F	G	H	I	J	K	L	M	N	P	Q	R			
100 mm (4")	597 mm (23.5")	203 mm (8")	584 mm (23")	338 mm (13.3")	8	19 mm (0.75")	229 mm (9")	108 mm (4.26")	191 mm (7.5")	22.5°	8	22 mm (0.875")	279 mm (11")	162 mm (6.37")	241 mm (9.5")	22.5°	413 mm (16.25")			
150 mm (6")	838 mm (33")	254 mm (10")	836 mm (33")	435 mm (17.1")	8	22 mm (0.875")	279 mm (11")	162 mm (6.36")	241 mm (9.5")	22.5°	8	22 mm (0.875")	343 mm (13.5")	212 mm (8.33")	286 mm (11.3")	22.5°	660 mm (26")			
200 mm (8")	1188 mm (46")	356 mm (14")	1168 mm (46")	577 mm (22.7")	8	22 mm (0.875")	343 mm (13.5")	212 mm (8.33")	286 mm (11.3")	22.5°	6	25 mm (1")	483 mm (19")	315 mm (12.39")	432 mm (17")	30°	711 mm (28")			
250 mm (10")	1321 mm (52")	406 mm (16")	1321 mm (52")	683 mm (27.3")	6	25 mm (1")	406 mm (16")	285 mm (10.42")	362 mm (14.25")	30°	6	28 mm (1.125")	533 mm (21")	346 mm (13.62")	476 mm (18.75")	30°	813 mm (32")			
300 mm (12")	1575 mm (62")	483 mm (19")	1575 mm (62")	838 mm (33")	6	25 mm (1")	483 mm (19")	316 mm (12.38")	422 mm (16.6")	30°	8	29 mm (1.125")	597 mm (23.5")	394 mm (15.5")	540 mm (21.25")	22.5°	914 mm (36")			

# Millflo Wiring

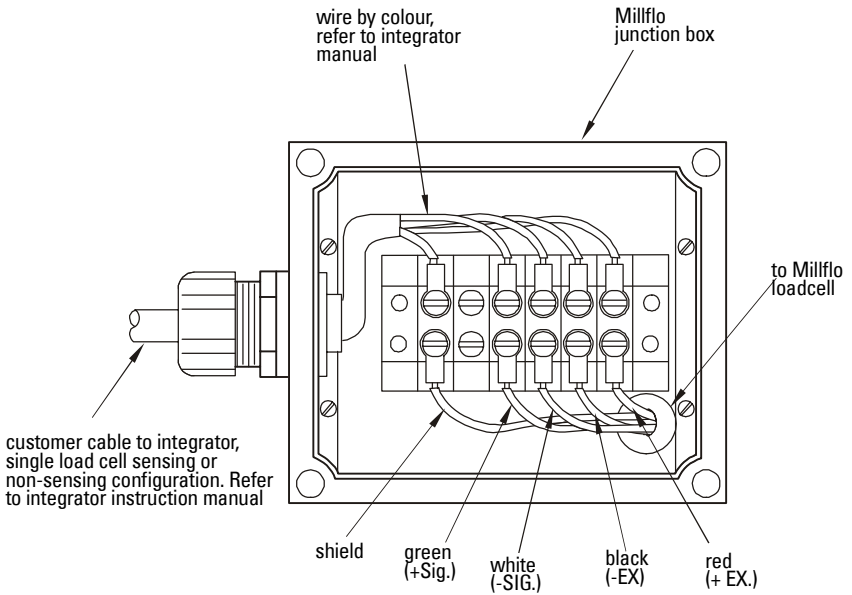

# Calibration

## General

After the Millflo has been properly installed, calibration of the solids flowmeter system should be done in conjunction with the integrator. Refer to the integrator instruction manual for programming and calibration. The calibration is initially done using a test weight. Material tests are recommended to achieve maximum accuracy.

## Test Rate

The test rate is the material flowrate represented by the test weight. The test weight is used to simulate the horizontal forces of the material hitting the sensing plate.

### CALCULATION OF TEST WEIGHT AND TEST RATE

Select the test weight to represent a calibration point of 60% to 80% of the Design flowrate based on the Millflo Calibration Constant of 45 g / T/H (tons per hour).<sup>1</sup>

Test Weight = Design Flowrate x Calibration Point x Calibration Constant

$$\text{Test Rate} = \frac{\text{Test Weight}}{\text{Calibration Constant}}$$

For Example:

If the Design Flowrate is 6 T/H, then

$$\begin{aligned}\text{Test Weight 60\%} \\ &= 6 \text{ T/H} \times 60\% \times 45 \text{ g / T/H} \\ &= 162 \text{ g}\end{aligned}$$

$$\begin{aligned}\text{Test Weight 80\%} \\ &= 6 \text{ T/H} \times 80\% \times 45 \text{ g / T/H} \\ &= 216 \text{ g}\end{aligned}$$

Therefore the test weight should be between 162 g and 216 g.

If an available test weight of 200 g is used, then

$$\begin{aligned}\text{Test Rate} &= \frac{200\text{g}}{45 \text{ g T/H}} \\ &= 4.444 \text{ T/H}\end{aligned}$$

---

<sup>1</sup> The Calibration Constant represents an average of a range of values covering various material flow arrangements and materials handled by the Millflo. It is an approximate value to be used in the calculation of the Test Rate. Through the running of material tests, the Test Rate may be factored to obtain an optimum value which should lie in the range of 50% to 100% of the Design Rate. The Test Rate should never exceed 100% of the Design Rate.

## Zero

Perform the zero calibration as described in the Calibration section of the integrator instruction manual.

## Span

1. Install the calibration pulley and bracket assembly to the flowmeter housing.
2. Hang the test weight over the calibration pulley using the test weight cable.
3. Perform the span calibration as described in the calibration section of the integrator instruction manual.
4. After the span calibration has been completed, remove the test weight and pulley assembly and store them.

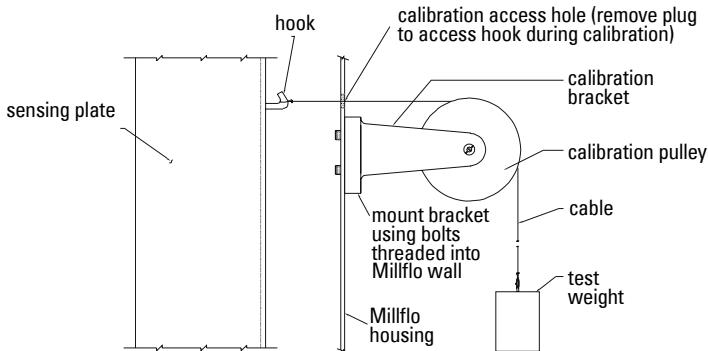

## Material Test

Calibration of the flowmeter by test weight is not a dynamic simulation and yields only an approximate span calibration. Effective material flow, friction, and velocity can only be reproduced by running actual material tests.

At least two 5 minute samples should be taken to ensure repeatability.

Refer to *Material Test* and subsequent *Factoring* of the flowmeter sections of the integrator manual.

## Re-Rating

After material tests have been done and a decision is made to re-rate the Millflo at a higher or lower capacity, (with 20% of the design rate specified at the time of purchase) only the design rate parameter of the integrator needs to be changed. Following that, a recalibration of the zero and span can be performed using the old test weight and test rate. New material tests will not be required.



# Applications

---

**Note:** For best performance and limited maintenance requirements, keep in mind material compatibility and flow patterns.

Ideal material characteristics:

- low cohesion (flows well through chutes, similar to a liquid)
- low adhesion (does not stick to surfaces)
- low abrasion (will not wear out chutes, flowguide, or sensing plate)
- low causticity (will not damage internal flowmeter components)

## Location

Materials with low moisture content generally have excellent flow and adhesion characteristics. In processes where material moisture content varies, select a flowmeter location where the moisture content is lowest.

## Linings

- Sensing plate and flowguide non-stick linings are often used for flour (wheat), starch, and material with similar characteristics.
- Sensing plate and flowguide abrasion resistant linings are often used for barley, corn, soya beans, wheat, and material with similar hardness and particle mass. Abrasive materials are best monitored at low velocity.

## Material Feed

Ideal material in-feed characteristics

- constant and relatively low material velocity
- uniform material flowrate (not pulsing)
- negligible air flow through the flowmeter
- flowguide 17% to 50% full during operation

## Feed Conditions

- A gravity-fed flowmeter generally provides accurate readings.
- A mechanically fed flowmeter may not provide a consistent feed, affecting flowmeter performance. A consistent feed provides the most accurate readings.
- A reverse flowguide transition is preferred for high or variable velocity feeder material discharges. (Refer to *Flowmeter Infeed Chutes* on page 15.)
- A larger loadcell compensates for slight to moderate material pulsing at greater than 1 pulse per second. If heavily pulsing feeder discharges at less than 1 pulse per second, consult Siemens Milltronics or your local distributor.
- Use a flowmeter discharge chute suitable so that material cannot backup into the flowmeter housing.

## Screw Conveyor

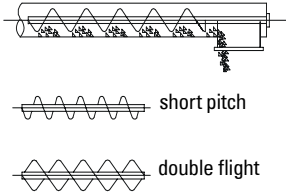

- Most common type of material feeder
- Short pitch and/or double flight screws are preferred. They reduce the batch size (and increase the frequency) of the material discharge pulses. Alternatively, the flights of a standard screw may be cut back, ending before the discharge opening.
- A reverse flowguide transition should be considered for variable operating speeds or constant speeds above 40 rpm.

## Rotary Feeder

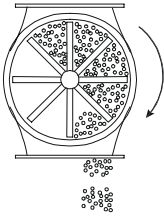

- Provides an air seal between the upstream and/or downstream process, and the flowmeter
- Required when the material is pneumatically conveyed or flowmeter/process isolation is required.
- Use a reverse flowguide transition for variable operating speeds or constant speeds above 10 rpm.

## Bucket Elevator

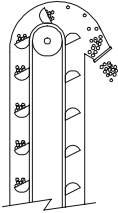

- Common to grain applications
- Slow elevators (typically chain drive) often produce heavily pulsing material discharge, requiring feeder discharge damping. Generally not suitable for the Millflo.
- Fast elevators (typically reinforced belt drive) often require a deadbox to reduce material velocity. High frequency of pulses make it suitable for the Millflo.

## Conveyor Belt

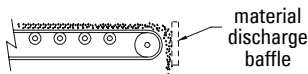

- Conveyor belts generally produce a non-pulsing material discharge, ideal for flowmeter operation.
- A reverse flowguide transition (and/or material discharge baffle) is often required for variable belt speeds or constant speeds in excess of 1 m/s (200 feet/minute).

## Vibratory Feeder

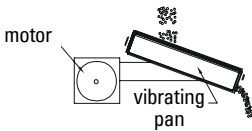

- Vibratory (pan) feeders produce a non-pulsing material discharge.
- A reverse flowguide transition should be considered for variable speed varieties.

## Flowmeter In-Feed Chutes

The flowmeter in-feed chute delivers the material from the bin or feeder discharge to the flowmeter flowguide. For optimal performance, in-feed chute is set to condition the material flow to minimize the following:

- abrasion
- velocity variation
- feeder discharge trajectory variation
- pulsing

## Feeder/Flowguide Transition

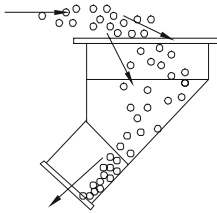

- A reverse flowguide transition reverses the direction of the bin or feeder material discharge before the material enters the flowmeter flowguide.
- Reversing direction forces the material into a desirable flow pattern, as opposed to permitting material to be flung from the feeder directly into the flowguide. This transition is especially important for high or variable speed feeders.

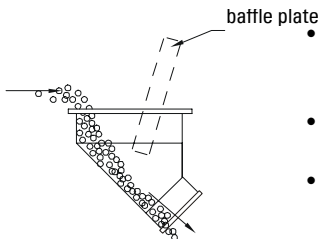

- A forward flowguide transition maintains the material in the same direction between the bin or feeder discharge and the flowmeter flowguide.
- This transition is acceptable for a low and constant velocity feeder.
- To use a forward flowguide transition for a high or variable speed feeder application, install a baffle plate.

## Short Fall Chute

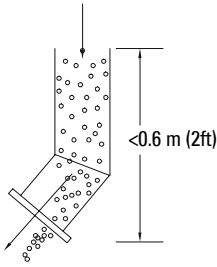

- A short fall chute is when the bin or feeder discharge to flowmeter flowguide fall is less than 0.6 m (2 ft) from the material infeed.
- The short fall chute presents ideal measurement conditions because material velocity due to gravity is minimum.
- The chute center line and angle should coincide with that of the flowguide for a distance greater than or equal to the flowguide diameter (before the flowguide inlet).

## Long Fall Chute

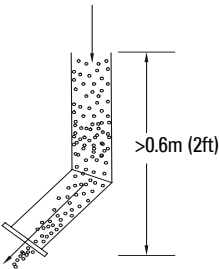

- A long fall chute is when the bin or feeder discharge/flowguide fall is more than 0.6 m (2 ft) from the material infeed.
- The long fall chute presents problematic conditions because material velocity is increased, increasing flowmeter component abrasion.
- Increased distances after chute-angle changes (to settle material into desirable flow patterns) are also required.

## Dogleg

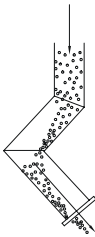

- Use a dogleg to reduce the detrimental effect of high or variable material velocity, and when a long fall chute is used.
- For abrasive material, line the chute with an abrasion resistant material or use an in-feed deadbox.

## Deadbox

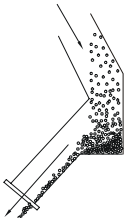

- Install a deadbox where the chute angle changes, causing the material to strike upon itself, rather than on the chute surface
- Deadboxes conditions:
  - high feeder discharge velocity
  - variable discharge
  - abrasive material
- Locate deadboxes where long-fall chute angles change.

## In-Feed/Discharge Air Pressure

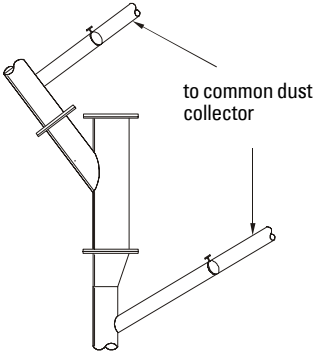

- Vent the in-feed and discharge chutes to a common dust collector if a material in-feed/discharge differential air pressure is anticipated and rotary airlock feeders are not used.
- A tuning gate can be installed in each vent to balance the air pressure.
- If a dust collector is not used, an air bypass chute can be installed between the flowmeter in-feed and discharge chutes.

## Flowguide Capacity

Refer to the following chart to ensure the flowguide capacity is suitable.

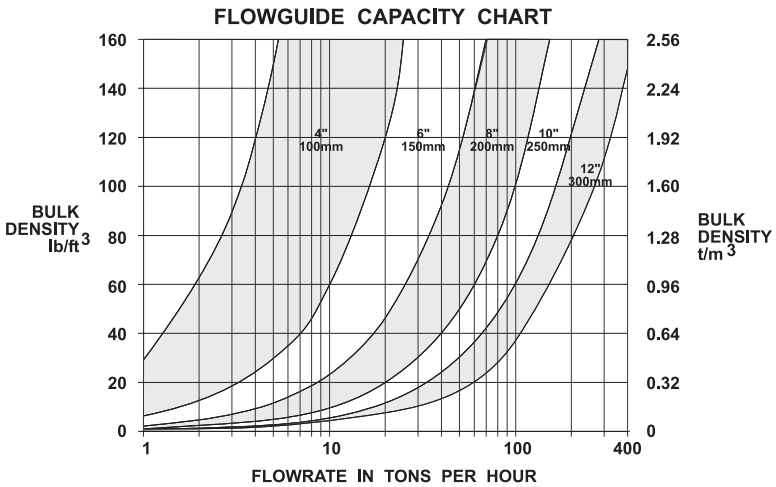

**Note:** If the material bulk density and flowrate is near a Millflo infeed diameter upper limit, choose the next largest diameter.

# Maintenance

---

## Periodic Recalibration

If the flowmeter is properly installed, the zero and span calibrations will require limited attention. However, to maintain the accuracy of your flowmeter's operation, the zero and span should be periodically redone. The frequency of recalibration is highly dependent upon the application in which the flowmeter is being used and the severity of its operating conditions. Initially frequent recalibrations should be performed (noting the deviations), then tapering off in frequency as time and experience dictate.

Refer to the *Programming* and *Calibration* sections of the integrator manual.

## Checks

If material sticks to the sensing plate, incorporate a program to ensure that the impingement area remains clean. If sticking of the material persists, contact your Siemens Milltronics representative.

Check for material bridging across the load cell or sensing plate to the housing which can restrict the free movement of either component.

Do not strike the flowmeter, its components, or adjacent piping to dislodge material.

Check for wearing of the sensing plate. If wear is excessive contact your Siemens Milltronics representative.

## Spare Parts

The following are the recommended spare parts. As each may be available in more than one option, consult Siemens Milltronics for assistance in ordering spare parts. In all correspondence please quote the Milltronics Serial Number of the unit for which the parts are required.

- load cell
- sensing plate

### Unit Repair and Excluded Liability

All changes and repairs must be done by qualified personnel and applicable safety regulations must be followed. Please note the following:

- The user is responsible for all changes and repairs made to the device.
- All new components must be provided by the Siemens Milltronics Process Instruments Inc.
- Restrict repair to faulty components only.
- Do not re-use faulty components.





[www.siemens-milltronics.com](http://www.siemens-milltronics.com)

Siemens Milltronics Process Instruments Inc.  
1954 Technology Drive, P.O. Box 4225  
Peterborough, ON, Canada K9J 7B1  
Tel: (705) 745-2431 Fax: (705) 741-0466  
Email: [techpubs@siemens-milltronics.com](mailto:techpubs@siemens-milltronics.com)

© Siemens Milltronics Process Instruments Inc. 2003  
Subject to change without prior notice



Printed in Canada

**Rev. 1.0**