

# Communications

SmartLinx Module - PROFIBUS DP

Operating Instructions · 02/2011

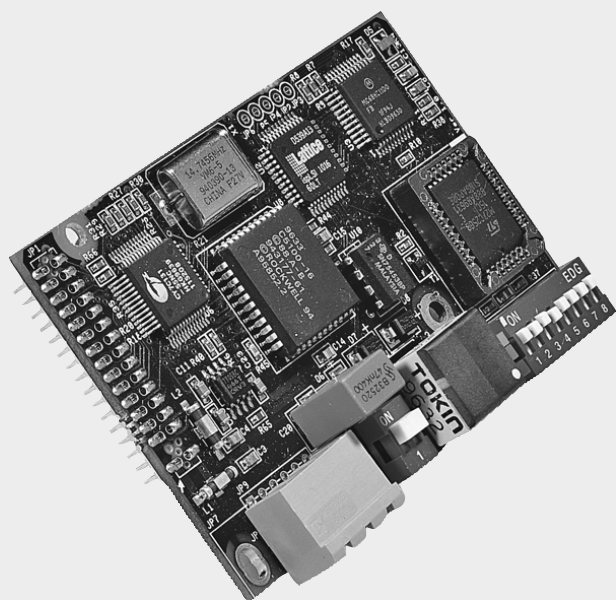

Milltronics

**SIEMENS**

**Safety Guidelines:** Warning notices must be observed to ensure personal safety as well as that of others, and to protect the product and the connected equipment. These warning notices are accompanied by a clarification of the level of caution to be observed.

**Qualified Personnel:** This device/system may only be set up and operated in conjunction with this manual. Qualified personnel are only authorized to install and operate this equipment in accordance with established safety practices and standards.

**Unit Repair and Excluded Liability:**

- The user is responsible for all changes and repairs made to the device by the user or the user's agent.
- All new components are to be provided by Siemens Milltronics Process Instruments.
- Restrict repair to faulty components only.
- Do not reuse faulty components.

**Warning:** Cardboard shipping package provides limited humidity and moisture protection. This product can only function properly and safely if it is correctly transported, stored, installed, set up, operated, and maintained.

**This product is intended for use in industrial areas. Operation of this equipment in a residential area may cause interference to several frequency based communications.**

**Note:** Always use product in accordance with specifications.

**Copyright Siemens AG 2011. All Rights Reserved**

**Disclaimer of Liability**

This document is available in bound version and in electronic version. We encourage users to purchase authorized bound manuals, or to view electronic versions as designed and authored by Siemens Milltronics Process Instruments. Siemens Milltronics Process Instruments will not be responsible for the contents of partial or whole reproductions of either bound or electronic versions.

While we have verified the contents of this manual for agreement with the instrumentation described, variations remain possible. Thus we cannot guarantee full agreement. The contents of this manual are regularly reviewed and corrections are included in subsequent editions. We welcome all suggestions for improvement.

Technical data subject to change.

MILLTRONICS® is a registered trademark of Siemens Milltronics Process Instruments.

**Contact SMPI Technical Publications**

**at the following address:**

Technical Publications  
Siemens AG  
Siemens Milltronics Process Instruments  
1954 Technology Drive, P.O. Box 4225  
Peterborough, Ontario, Canada, K9J 7B1  
Email: [techpubs.smpi@siemens.com](mailto:techpubs.smpi@siemens.com)

**European Authorized Representative**

Siemens AG  
Industry Sector  
76181 Karlsruhe  
Deutschland

- For a selection of Siemens Milltronics level measurement manuals, go to: **[www.siemens.com/processautomation](http://www.siemens.com/processautomation)**. Under Process Instrumentation, select *Level Measurement* and then go to the manual archive listed under the product family.
- For a selection of Siemens Milltronics weighing manuals, go to: **[www.siemens.com/processautomation](http://www.siemens.com/processautomation)**. Under Weighing Technology, select *Continuous Weighing Systems* and then go to the manual archive listed under the product family.

# Table of Contents

---

Safety Notes.....	1
The Manual .....	1
Technical Support.....	2
<b>SmartLinx PROFIBUS DP .....</b>	<b>3</b>
<b>Specifications .....</b>	<b>4</b>
<b>Installation.....</b>	<b>5</b>
Compatibility.....	5
Software Compatibility.....	5
Hardware Compatibility.....	6
Cable Connector.....	8
Termination Switch .....	10
<b>Operation .....</b>	<b>11</b>
Error Status LEDs .....	11
Error Conditions of the Red Diagnostics Light .....	12
Operation LED .....	12
<b>Communication Setup .....</b>	<b>13</b>
GSD Files.....	13
Baud Rate .....	13
Bus Address.....	13
Configuring the Slave Device.....	14
Map Element Selection .....	15
P762 Map Element Selection parameter.....	15
Module Identification .....	17
P794 SmartLinx Module Type.....	17
P795 SmartLinx Protocol .....	17
P634: Communication Totalizer Resolution.....	18
<b>Application Layer .....</b>	<b>19</b>
Parameter Indexes .....	19
Primary Index.....	19
Secondary Index .....	20
Data Access Methods .....	20
Direct Access.....	20
Multiple Parameter Access (MPA) .....	21
Single Parameter Access (SPA).....	22
Data Map: Level Products .....	24
Write Block.....	24
Read Block.....	27
Data Map: Mass Dynamic Products .....	30
Write Block.....	30
Read Block.....	34

Data Types.....	40
Integer.....	40
Bit Values.....	40
Unsigned Double Precision Integer (UINT32).....	41
Split Values.....	41
Text Messages.....	42
Relay Function Codes (P111 in Level Products Only).....	43
<b>Troubleshooting .....</b>	<b>45</b>
Generally.....	45
Technical Support or Product Feedback.....	45
<b>Appendix A – Reducing the amount of data being transferred over the Bus .....</b>	<b>46</b>
Level Products.....	46
Write Block.....	47
Read Block.....	49
Mass Dynamics Products.....	51
Write Block.....	52
Read Block.....	54
<b>Index.....</b>	<b>57</b>

# Safety Notes

Special attention must be paid to warnings and notes highlighted from the rest of the text by grey boxes.



**WARNING:** relates to a caution symbol on the product, and means that failure to observe the necessary precautions can result in death, serious injury, and/or considerable material damage.



**WARNING:** means that failure to observe the necessary precautions can result in death, serious injury, and/or considerable material damage.

**CAUTION:** means that failure to observe the necessary precautions can result in considerable material damage.

**Note:** means important information about the product or that part of the operating manual.

## The Manual

### Note:

- Please follow the installation and operating procedures for a quick, trouble-free installation and to ensure the maximum accuracy and reliability of your Siemens Milltronics SmartLinx PROFIBUS DP module.
- This manual applies to the SmartLinx PROFIBUS DP module only.

This manual will help you install and connect a Siemens Milltronics SmartLinx PROFIBUS DP module, and set it up for communication with a master device on a PROFIBUS DP network. The manual is targeted at a technical audience in the industrial communications field with a sound working knowledge of PROFIBUS DP.

We always welcome questions, comments, or suggestions about manual content, design, and accessibility.

Please direct your questions or comments to [techpubs.smpi@siemens.com](mailto:techpubs.smpi@siemens.com). For the complete library of Siemens Milltronics manuals, go to [www.siemens.com/processautomation](http://www.siemens.com/processautomation).

# Technical Support

Support is available 24 hours a day.

To find your local Siemens Automation Office address, phone number and fax number go to:

[www.siemens.com/automation/partner](http://www.siemens.com/automation/partner)

- Click on the tab **Contacts by Product** then drill down to find your product group (**+Process Automation > +Process Instrumentation > +Level Measuring Instruments**).
- Select the team **Technical Support**. Click on **Next**.
- Click on the appropriate continent, then select the country followed by the city. Click on **Next**.

For on-line technical support go to:

[www.siemens.com/automation/support-request](http://www.siemens.com/automation/support-request)

- Enter the device name or order number, then click on **Search**, and select the appropriate product type. Click on **Next**.
- You will be prompted to enter a keyword describing your issue. Then either browse the relevant documentation, or click on **Next** to email a detailed description of your issue to Siemens Technical Support staff.

**Siemens IA/DT Technical Support Center:** phone +49 (0)911 895 7222

# SmartLinX PROFIBUS DP

**Note:** This product is intended for use in industrial areas. Operation of this equipment in a residential area may cause interference to several frequency based communications.

The Siemens Milltronics SmartLinX<sup>1</sup> PROFIBUS DP module is a plug-in communications card designed to interface a Siemens Milltronics SmartLinX-compatible instrument to a PROFIBUS DP network.

Only those instruments which support the PROFIBUS DP protocol can use this card. See *Compatible Instruments*: on page 4 for a list of SmartLinX-compatible Siemens Milltronics instruments.

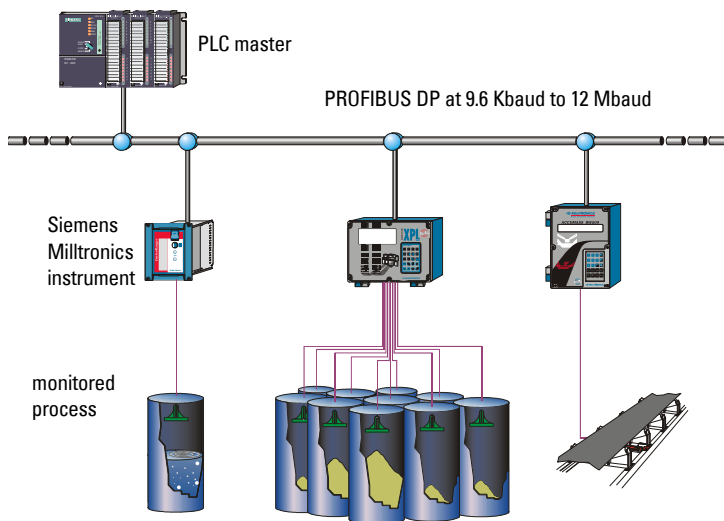

PROFIBUS is an open standard controlled by PROFIBUS industry groups worldwide. More information is available on the web site at [www.profibus.com](http://www.profibus.com).

**Note:** Siemens Milltronics does not own the PROFIBUS DP protocol. All information regarding that protocol is subject to change without notice.

<sup>1</sup> SmartLinX<sup>®</sup> is a registered trademark of Siemens Milltronics Process Instruments Inc.

# Specifications

---

## Application:

- compatible with a master device on a PROFIBUS bus

## Compatible Instruments:

- AiRanger XPL Plus / SITRANS LU 10
- AiRanger DPL Plus / SITRANS LU 02
- AiRanger SPL / SITRANS LU 01
- CraneRanger
- InterRanger DPS 300
- EnviroRanger ERS 500
- Milltronics BW500
- Milltronics BW500/L
- Milltronics SF500
- MultiRanger 100/200
- HydroRanger 200

## Communication Settings:

- baud rate: 9.6 Kbaud to 12 Mbaud, automatically detected

## Connection:

- varies by Siemens Milltronics SmartLinx<sup>®</sup> instrument, (see page 8)

## Termination:

- switch selectable, open or special active termination as per PROFIBUS specification  
(see *Termination Switch* on page 10)

## Cable:

- Belden PROFIBUS cable 3079A, or equivalent



# Installation

The SmartLinx module is either shipped already installed in the Siemens Milltronics instrument or separately for on-site installation. Refer to the manual of your Siemens Milltronics instrument for details on module location and physical installation.

## Compatibility

For the SmartLinx PROFIBUS card there are different hardware and software configurations available depending on the equipment used.

## Software Compatibility

If a device is SmartLinx ready, it will work with the correct SmartLinx card for that device. However, if the firmware version is a lower number than the one listed below, the Map Element Selection Parameter (P762) will not be available. Also, for the BW500, BW500/L, and SF500, the read block will be a smaller size.

Product	Software Rev.	Product	Software Rev.
AiRanger XPL Plus / SITRANS LU 10	5.23	Milltronics BW500/L	3.13
AiRanger DPL Plus / SITRANS LU 02		Milltronics BW500	3.05
		Milltronics SF500	
AiRanger SPL / SITRANS LU 01		MultiRanger 100	1.04
InterRanger DPS 300		MultiRanger 200	1.03
	HydroRanger 200		
	EnviroRanger ERS 500	5.06	

## Retrofits

If you are replacing an older SmartLinx device with a new SmartLinx device, and you are using any product other than the BW500, BW500/L, or SF500, then you can use the default values for P762.

If you are replacing a BW500, BW500/L, or SF500 with a new device, then set P762 primary index 15 = 0, and P762 primary index 16 = 0.

# Hardware Compatibility

All available SmartLinX card configurations are shown here for reference.

## The card shown below is compatible with the following Siemens Milltronics units:

- AiRanger XPL Plus / SITRANS LU 10
- AiRanger DPL Plus / SITRANS LU 02
- AiRanger SPL / SITRANS LU 01
- CraneRanger
- InterRanger DPS 300

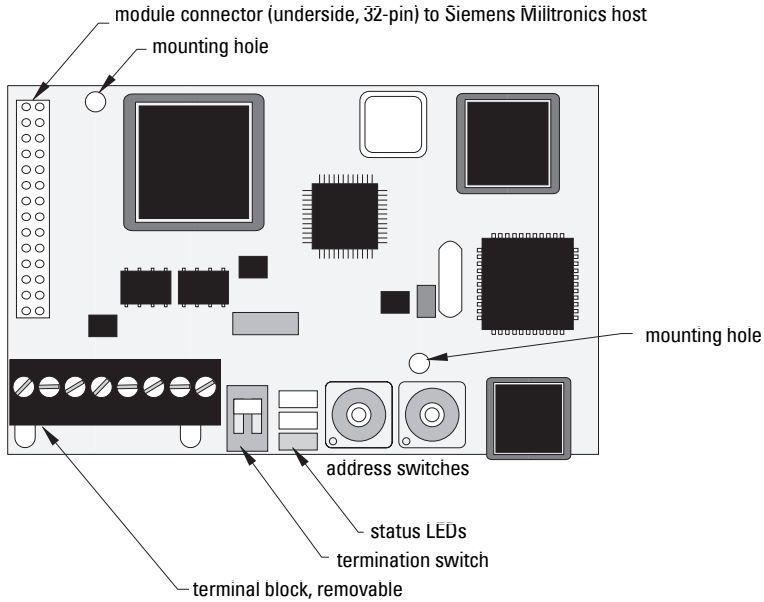

**The card shown below is compatible with the following Siemens Milltronics units:**

- EnviroRanger ERS 500 (Wall Mount)
- Milltronics SF500
- Milltronics BW500
- MultiRanger 100/200
- Milltronics BW500/L
- HydroRanger 200

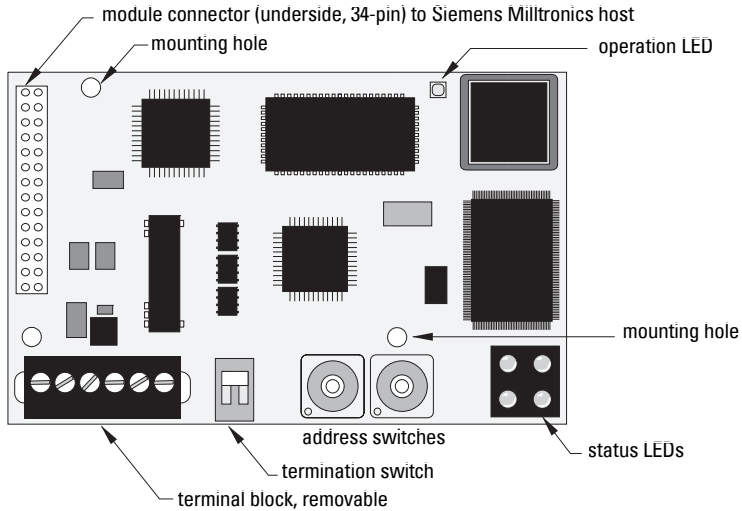

**Note:**

- Install the SmartLinx card so that the mounting holes align and the pin connectors will mate correctly.
- Correct cable routing is important for electromagnetic noise suppression. Follow the routing instructions contained your unit's instruction manual.

**The card shown below is compatible with EnviroRanger ERS 500 (Rack or Panel Mount)**

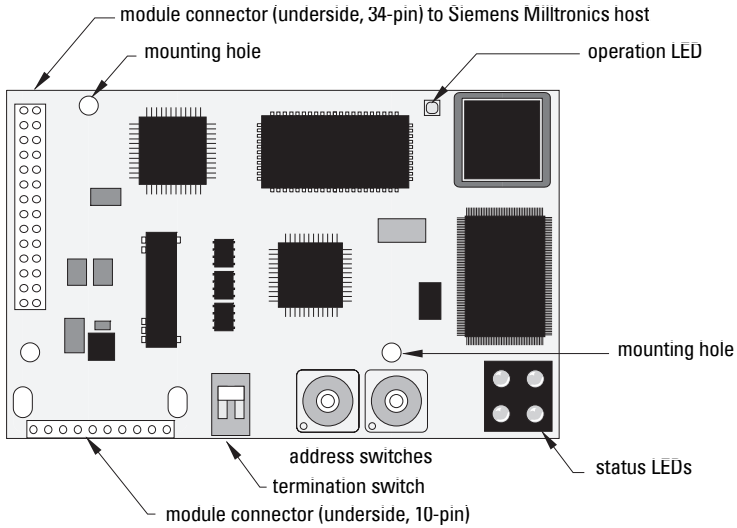

## Cable Connector

Connect using Belden PROFIBUS cable 3079A or equivalent and terminate according to PROFIBUS DP specification and conventions.

### AiRanger / SITRANS LU Series, CraneRanger, InterRanger DPS 300

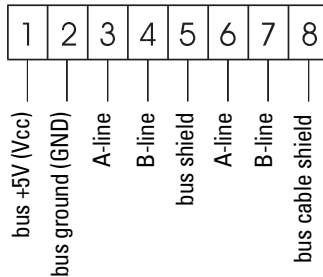

**Note:** To daisy-chain devices, connect both the outgoing and the incoming wires to terminals 3 and 4. Then if you have to remove the connector, the bus will still be active.

**EnviroRanger ERS 500 (Wallmount), Milltronics BW500, Milltronics BW500/L, Milltronics SF500, MultiRanger 100/200, HydroRanger 200**

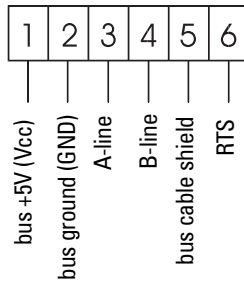

**Note:**

- To daisy-chain devices with the BW500, BW500/L or SF500, connect both wires to the existing A-line and B-line terminals.
- RTS is used in some equipment to determine the direction of transmission. In normal applications only A-line, B-line, and shield, are used.

**EnviroRanger ERS 500 (Rack or Panel Mount)**

When using a SmartLinX card with the EnviroRanger (rack or panel mount) all wiring is made to the EnviroRanger terminal board. The PROFIBUS connections map to the EnviroRanger terminal board as shown:

EnviroRanger	Connection
65	Gnd_bus
66	RTS <sup>1</sup>
68	A
69	B
71	V_bus +5V
67	bus cable shield

1. RTS is used in some equipment to determine the direction of transmission. In normal applications only A-line, B-line, and shield, are used.

# Termination Switch<sup>1</sup>

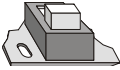
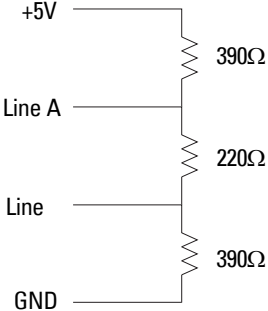
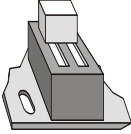
Termination	Setting	Switch Position
open (not used)	off	
	on	

PROFIBUS DP requires termination of the bus at both end points. See the PROFIBUS DP specifications for details.

<sup>1</sup> The termination switch is not present on all cards.

# Operation

Communication on the PROFIBUS DP link is indicated by the SmartLinX LEDs.

## Error Status LEDs

**AiRanger / SITRANS LU Series, CraneRanger, InterRanger DPS 300**

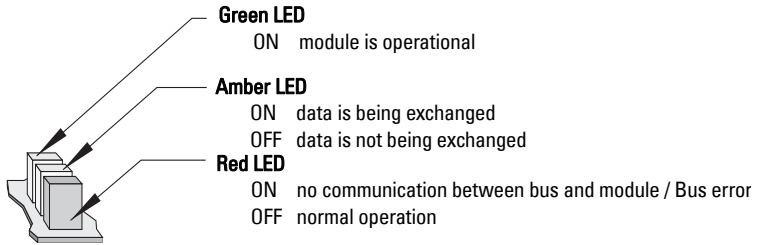

**EnviroRanger ERS 500, Milltronics BW500, Milltronics BW500/L, Milltronics SF500, MultiRanger 100/ 200, HydroRanger 200**

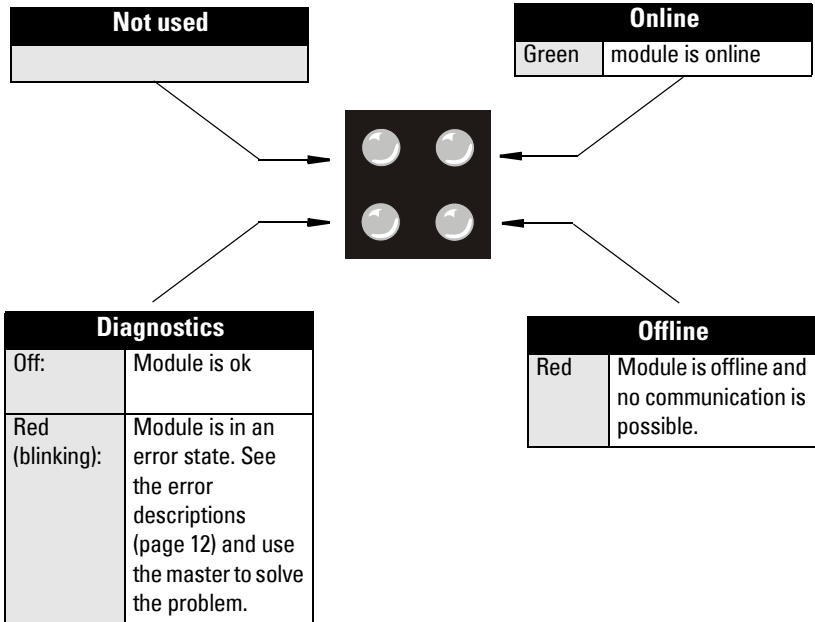

# Error Conditions of the Red Diagnostics Light

## 1Hz – Error in Configuration

Indicates that the I/O length variable set during initialization is not equal to the length set during configuration of the network. See *Configuring the Slave Device* on page 14 for lengths supported by the SmartLinx module, and see your PLC documentation for setting the I/O length variable.

## 2Hz – Error in User Parameter Data

Indicates that the length and / or contents of the user parameter data set during initialization of the module is greater than the length and/or contents set during configuration of the network. See *Configuring the Slave Device* on page 14 for supported lengths.

## 4Hz – Error in Initialization

Consult your Siemens Milltronics representative.

# Operation LED

**EnviroRanger ERS 500, Milltronics BW500, Milltronics BW500/L, Milltronics SF500, MultiRanger 100/200, HydroRanger 200**

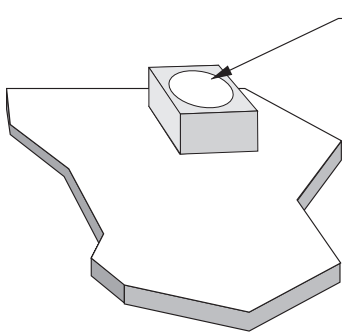

LED

- blinks orange as the module is initialized
- blinks green during normal operation



# Communication Setup

---

The SmartLinX PROFIBUS DP module is a slave on the bus, and does not use any Siemens Milltronics instrument parameters for configuration. Set the rotary switches on the module to the desired slave address: other settings are provided in the GSD file or are automatically detected.

## GSD Files

PROFIBUS master devices require a configuration file for each slave device on the network. This file configures the master for the capabilities and limitations of the slave. For the SmartLinX PROFIBUS DP module these files are:

- AiRanger / SITRANS LU Series      hms\_1002.gsd
- BW500, BW500/L, SF500,      hms1003.gsd  
  HydroRanger 200,  
  MultiRanger 100/200, and ERS 500

Both files are supplied on the floppy disk that is shipped with the module.

The file hms\_1002.gsd uses the manufacturer's I.D. number of 1002 hexadecimal (4,098 decimal). The file hms1003.gsd uses the manufacturer's I.D. number 1003 hexadecimal (4,099 decimal).

## Baud Rate

The SmartLinX PROFIBUS module automatically configures itself to the correct baud rate for the PROFIBUS DP network. Follow the PROFIBUS guidelines with regards to bus length and baud rate.

## Bus Address

Set the two rotary switches to the address for this slave.

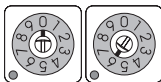
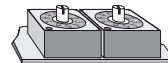

Use a slave address switch in the range 03 to 99. This example shows the value "06".

# Configuring the Slave Device

Use the configuration software (or any equivalent master commands) to configure the slave. Refer to the information that came with the PROFIBUS master. The Siemens Milltronics instrument appears as a modular type slave, and should be configured as shown below.

After you import the GSD file, you can find the hardware in the hardware catalogue. If you are using Step 7, go to PROFIBUS DP > Additional Field Devices > General.

- For AiRanger / SITRANS LU products, select **AB-DT-PDR**.
- For all other products, select **Anybus-S\_PDP**.

Then define two universal modules: one input module and one output module.

The data size of the input and output modules is dependent on P762, and on the type of unit the module is plugged into, (either Level or Mass Dynamics). (The following instructions assume that P762 is set to the default values shown in the chart on page 16.)

## **Level Products (includes AiRanger / SITRANS LU Series, ERS 500, MultiRanger 100/200, HydroRanger 200)**

- 42 words input (see *Write Block* on page 24)
- 13 words output (see *Read Block* on page 27)
- read and write data as 16-bit words (see *Data Types* on page 40)

## **Mass Dynamics Products (includes BW500, SF500)**

- 34<sup>1</sup> words input (see *Write Block* on page 30)
- 19 words output (see *Read Block* on page 34)
- read and write data as 16-bit words (see *Data Types* on page 40)

## **Mass Dynamics Products (BW500/L)**

- 23 words input (see *Write Block* on page 30)
- 10 words output (see *Read Block* on page 34)
- read and write data as 16-bit words (see *Data Types* on page 40)

If your PROFIBUS master is not capable of handling the block sizes listed above then use multiple smaller blocks. (See next page for examples.)

---

<sup>1</sup> 34 is the correct value for BW500/SF500 units that have firmware V 3.05 or greater and have all the values of P762 turned on. For older units, the input size is 31 words.

**Example:**

An S5-115U with an IM 308C master would use the following:

**For Level products:**

**Inputs:** 3 address blocks of 16, 16, and 10 words

**Outputs:** 1 address block of 13 words

**For Mass Dynamics products:**

**Inputs:** 3 address blocks of 16 words, 16 words, and 2 words<sup>1</sup>

**Outputs:** 2 address blocks of 16 and 3 words

**Notes:**

- Data is read and written with the most significant byte (MSB) first.
- The address and size of the Reads and Writes in the PLC must match the Siemens Milltronics device (see above). If the PLC size is smaller than the Siemens Milltronics size, an error will be displayed and only the first portion of the data will be read.
- PROFIBUS DP diagnostic bytes are not supported, however, some diagnostic information can be accessed via reading and writing the data areas. See *Application Layer* on page 19.

## Map Element Selection

### P762 Map Element Selection parameter

*P762 allows you to select what elements to include in the Input and Output Tables. By selecting only the data required, you can reduce the amount of data being transferred over the bus.*

**Notes:**

- P762 should only be modified by an advanced user who wants to limit the amount of data being transferred. See *Appendix A – Reducing the amount of data being transferred over the Bus* on page 46 for more details.
- Changes do not take effect until after a power cycle.

The chart on page 16 gives the default values for this parameter. If the default values are used then the configuration and Data Maps (see pages 24 and 30) in the main body of this manual remain correct. If any of these values is changed, then the Data Maps will be shortened and the configuration will change. Please see Appendix A on page 46 for details on how to use P762.

---

<sup>1</sup> This applies to BW500/SF500 units that have firmware V 3.05 or greater and have all the values of P762 turned on--it does not apply to older units.

**AiRanger / SITRANS LU,  
EnviroRanger, MultiRanger**      **BW500, BW500/L, SF500**

P762 Index	Name of area	Default value	Range	Name of area	Default value		Range
					SF500, BW500	BW500/L	
1	Instrument status	1	0 = No 1 = Yes	Instrument status	1	1	0 = No 1 = Yes
2	Reading	10	0 = No 1...10 = include that number of items	Rate	1	1	0 = No 1 = Yes
3	Alarm	10	0 = No 1...10 = include that number of items	Load	1	1	0 = No 1 = Yes
4	Point-on-priority	1	0 = No 1 = Yes	Speed	1	1	0 = No 1 = Yes
5	MPA	1	0 = No 1 = Yes	Total	1	1	0 = No 1 = Yes
6	SPA	1	0 = No 1 = Yes	Relay Status	1	1	0 = No 1 = Yes
7	Operating Mode	1	0 = No 1 = Yes	DI Status	1	1	0 = No 1 = Yes
8				SPA	1	1	0 = No 1 = Yes
9				Command Control	1	1	0 = No 1 = Yes
10				MultiSpan	1	0	0 = No 1 = Yes
11				PID	1	0	0 = No 1 = Yes
12				Batch	1	0	0 = No 1 = Yes
13				Batch Prewarn	1	0	0 = No 1 = Yes
14				Word Order	1	1	0 = No 1 = Yes
15				Status 2	1 <sup>1</sup>	1	0 = No 1 = Yes
16				Batch Total	1 <sup>1</sup>	0	0 = No 1 = Yes

1. For firmware V 3.05, the default is 0. For all higher versions, the default is 1.

# Module Identification

Parameters P794 and P795 are used together to identify the module type and protocol used.

## P794 SmartLinX Module Type (Read only)

Identifies the module used.

Value	Module
0	No module present
1	Anybus DT module
2	Anybus S module

## P795 SmartLinX Protocol (Read only)

Identifies the protocol used: the value varies according to the module, and whether it is a type 1 or type 2.

Siemens Milltronics Instrument	Card	P794 value	P795 value
ERS 500, BW500, BW500/L, SF500, MultiRanger 100/200	AB RIO	1	72
	PROFIBUS DP	2	1
	DeviceNet	2	37
AiRanger, SITRANS LU	AB RIO	1	72
	PROFIBUS DP	1	0
	DeviceNet	1	24
	Modbus RTU	1	57
	Modem Card	1	133

# P634: Communication Totalizer Resolution

Parameter P634 is used to set the number of fixed decimal places for Total 1 and Total 2 for SmartLinX communication.

**Note:** P634 applies only to Milltronics BW500, Milltronics BW500/L and Milltronics SF500.

P634 Index	Description	Value	# of decimal places	
Primary Index 1	Total 1 for SmartLinX communication	3	*	3
		2		2
		1		1
		0		0
Primary Index 2	Total 2 for SmartLinX communication	3	*	3
		2		2
		1		1
		0		0

\* Factory setting

This section describes the meaning of data read from and written to the Siemens Milltronics SmartLinX instrument slave memory. The output words (PLC master Write operation) and input words (PLC master Read operation) are described in the Data Map for Level Products on page 24 and the Data Map for Mass Dynamic Products on page 30.

## Parameter Indexes

Most parameters used on Siemens Milltronics SmartLinX instruments are indexed. Indexing allows a parameter to relate to more than one input or output. For example, many parameters are indexed by measurement point while others are indexed by relay output or discrete input.

The way that indexes are handled in the memory map depends on the data access method used.

## Primary Index

An index that relates to an input or output is called a Primary Index. (On some older Siemens Milltronics products the primary index is called a point.)

**Example:**

$$P111[3] = 52$$

means P111 (Relay Control Function) for relay 3 is set to value 52.

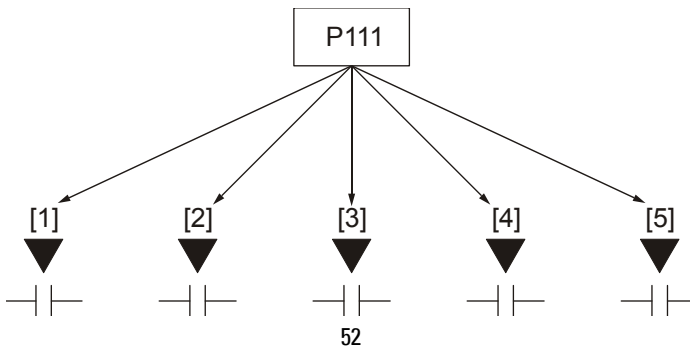

## Secondary Index

Sometimes a parameter requires a second index to allow for multiple values on an indexed input or output. For example a measurement point which calculates a reading on volume can require characterization breakpoints. These breakpoints are given on a secondary index (the primary index relates to the transducer input).

An index that relates to a previously indexed parameter is called a secondary index. (On some older Siemens Milltronics products the secondary index is called a mark.)

### Example:

$$P054[1,3] = 1.6m$$

means P054 (Breakpoint Levels) for breakpoint 3 on transducer 1 is set to 1.6m

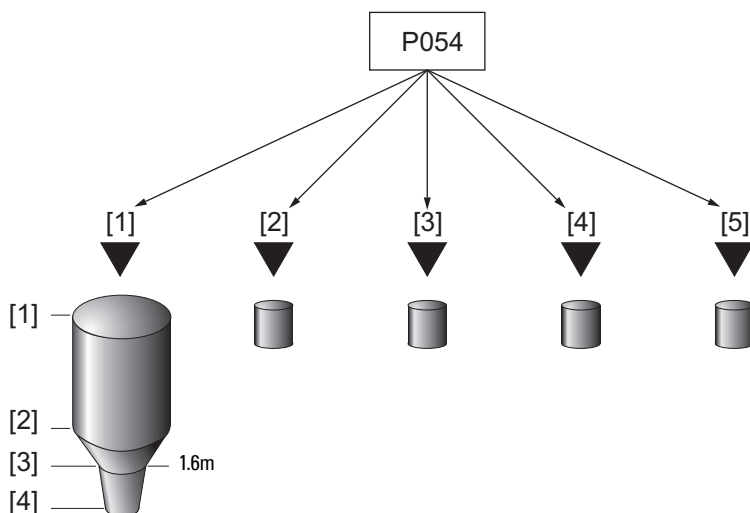

## Data Access Methods

There are three different methods used in the memory mapping to give access to the SmartLinX Instrument parameter table. They are:

- Direct Access
- Multiple Parameter Access (MPA)
- Single Parameter Access (SPA)

### Direct Access

Certain values are mapped directly into words. These words can be monitored continuously but they are not configurable.



## Multiple Parameter Access (MPA)

**Note:**

- MPA is used on Level products only.
- In Siemens Milltronics' products, the memory is arranged as Parameter number, Primary Index, Secondary Index.

This is a hand-shaking method where the user specifies the parameter number, secondary index, decimal place, and format, then the SmartLinx writes into a certain area all 10 primary indexes of that parameter.

### Using Multiple Parameter Access (MPA)

1. In the output table of the PLC (Write Block) write the values for the parameter number, secondary Index, decimal place and format in the correct location.
2. Monitor the Input table of the PLC (Read Block), and watch for the values you wrote to appear in the appropriate locations of the Read block, then go to Step 3.
3. Read the requested values in the appropriate location of the Read Block. These values are continuously updated. Continue reading from these words until values for another parameter are required. At that time, go to step 1.

**Note:** MPA values are only updated in Run mode (word 12 = 0).

### Parameter Indexing with MPA

#### Primary Index

The primary index is implicit in the memory address. MPA values are returned through words 21 to 30 of the Read block (see page 27).

#### Secondary Index

The secondary index is nearly always left at zero. See the Siemens Milltronics SmartLinx-compatible instrument manual for information on parameters, including those which require a secondary index.

## Single Parameter Access (SPA)

**Note:** SPA is used on both Level and Mass Dynamics products.

This is a hand-shaking method where the PLC specifies:

- parameter number
- primary index
- secondary index
- decimal place
- format
- read/write flag
- value

With this method any value in the Siemens Milltronics product can be read or written.

**Note:** Parameter P999 (Master Reset) is not accessible via the SmartLinX interface on Level products.

### Using Single Parameter Access (SPA)

SPA allows continuous monitoring or demand programming of a parameter.

#### Reading a Parameter

1. Set the Read/Write flag in the output table (Write Block) to 0, "Read"
2. Write the Parameter Number, Primary Index, Secondary Index, Decimal Place, and Format in the correct locations.

**Note:** If there is no secondary index, then place a 0 in this location.

3. Monitor the Input table of the PLC (Read Block) and watch for the values you wrote to appear in the appropriate locations, then go to Step 4.
4. Read the requested parameter value in the Input table (Read Block). These values are continuously updated. Continue reading from these words until values for other parameters are required. At that time, go back to step 1.

## Writing a Parameter

1. Set the Read/Write flag in the output table (Write Block) to **0**, "Read."
2. Write the Parameter Number, Primary Index, Secondary Index, Decimal Place, and Format in the correct locations.
3. Write the new value of the parameter into the correct location of the output memory (Write Block)
4. Verify the unit is in program mode (not needed for BW500, BW500/L and SF500). For Level see bit 10 of status word in Read Block.
5. If the unit is not in program mode, write a **1** to the operating mode word in the output memory (Write Block). Please note that writing a **1** will only work if the word is currently a **0**; if not, you need to change it to **0** before writing a **1** so it can take effect.
6. Set the Read/Write flag in the output table (Write Block) to a **1** "write."
7. Monitor the Input table of the PLC (Read Block) and watch for the values you wrote to appear in the appropriate locations.
8. Set Read/Write flag back to **0**.
9. Place unit in Run mode.

**Note:** Parameters for Level Products should only be written to while the unit is in PROGRAM mode. If the level instrument is still in RUN mode, the written value might be ignored.

# Data Map: Level Products

**Note:** The data maps shown for the Write and Read Blocks apply if P762 is set to the default values (see page 15). If any of these values is changed, the data map will be shortened and the configuration will change. (See *Appendix A – Reducing the amount of data being transferred over the Bus*, on page 46.)

This section describes the meaning of the data read from and written to the Siemens Milltronics SmartLinX instrument.

## Write Block

Word	Description	Access	Data Type
0	measurement point-on-priority	direct	bitmapped
1	parameter number	MPA	integer
2	secondary index (mark)		integer
3	decimal place		integer
4	format		0/1
5	parameter number	SPA	integer
6	primary index (point)		integer
7	secondary index (mark)		integer
8	new value		integer
9	decimal place		integer
10	format		0/1
11	read/write flag		0/1
12	operating mode	direct	0/1

### Word 0: Point-on-Priority

Bits 00-09 set the priority status of corresponding indexed points 1 to 10.

bit	09	08	07	06	05	04	03	02	01	00
index	10	9	8	7	6	5	4	3	2	1

bit status    **0** = normal  
                   **1** = priority

For example, if bits 00 and 02 are set to **1**, then points 3 and 1 are on priority scan. All other bits are reserved and contain **0**.

bit	09	08	07	06	05	04	03	02	01	00
index	0	0	0	0	0	0	0	1	0	1

The Siemens Milltronics instrument must be configured to use word 0 to control point-on-priority. For each point, set parameter P720 to **1**, to permit priority control for that point.

**Note:** Point-on-priority only applies to the AiRanger XPL+/SITRANS LU 10.

### Word 1: Parameter Number, MPA

Specifies the parameter number for the returned values in words 21 to 30 (see *Read Block* on page 27).

### Word 2: Secondary Index, MPA

Specifies the secondary index for the parameter specified by word 1. This word is ignored for parameters that don't use multiple indexes (see *Parameter Indexes* on page 19 for more information).

### Word 3: Decimal Place, MPA

Specifies the number of decimal places to shift the returned values in words 21 to 30 of the Read Block. Positive values indicate that the decimal place shifts to the left, and negative values indicate that the decimal place shifts to the right.

For example:

word 3 = **1**: all returned values have the decimal place shifted 1 space to the left and a returned value of 5,213 is interpreted as 521.3

word 3 = **-1**: a returned value of 5,213 is interpreted as 52,130

### Word 4: Format, MPA

Sets the format for the returned values in words 21 to 30.

**0** = normal

**1** = percent

**Note:** When the format is selected as "percent" the decimal place value (word 3 of the Write block) is ignored and two decimal places are always used. For example, a value of 5947 represents 59.47%.

### Word 5: Parameter, SPA

Specifies the parameter number for Single Parameter Access (SPA), see page 22.

### Word 6: Primary Index, SPA

Specifies the primary index number for the parameter in word 5.

### Word 7: Secondary Index, SPA

Specifies the secondary index for the parameter in word 5. This word is ignored for parameters that don't use multiple indexes (see *Parameter Indexes* on page 19 for more information).

## Word 8: New Value, SPA

This word contains the value written to the specified parameter and index. The format of this word is specified by words 9 to 10.

To write a value, ensure word 11 = 1 and word 12 = 1 (see also: *Data Types* on page 40).

## Word 9: Decimal Place, SPA

This word specifies the number of decimal places for the value in word 8 of the Write Block, and word 38 of the Read Block. Positive values indicate that the decimal place shifts to the left, and negative values indicate that the decimal place shifts to the right.

For example:

word 9 = 1: all returned values have the decimal place shifted 1 space to the left and a returned value of 5,213 is interpreted as 521.3

word 9 = -1: a returned value of 5,213 is interpreted as 52,130

## Word 10: Format, SPA

This word sets the format for the value in word 8 of the Write Block and word 38 of the Read Block.

0 = normal

1 = percent

## Word 11: Read/Write Flag, SPA

This word instructs the read/write application of word 8.

0 = read parameter as described by words 5, 6, 7, 9, and 10; word 8 ignored

1 = set parameter to the value described by words 5 to 10

## Word 12: Operating Mode

This word sets the operating mode of the Siemens Milltronics SmartLinX instrument.

The operating mode can get out of sync if the remote instrument resets back to run mode locally. This can happen due to a time-out or through local programming. The mode is always reported correctly through the Read block. (See bit 10 of *Word 0: Instrument Status* on page 27.)

To reset the instrument to program mode, write 0 to synchronize the SmartLinX module with the instrument and then write 1 to set the instrument to program mode.

0 = run mode

1 = program mode

## Read Block

Values in words 0 to 20, and word 41, are directly available: no write operation is required to request them.

Values in words 21 to 41 are determined by the write operation that requested them, either MPA or SPA (see *Write Block* on page 24).

Words	Description	Access	Data Type
0	instrument status		bitmapped
1-10	point reading	direct	integer
11-20	point alarm and status		bitmapped
21-30	returned values		integer
31	decimal place		integer
32	format	MPA	0/1
33	parameter number		integer
34	secondary index		integer
35	parameter		integer
36	primary index		integer
37	secondary index		integer
38	returned value	SPA	integer
39	decimal place		integer
40	format		0/1
41	read/write flag		0/1

### Word 0: Instrument Status

Bit	Description																						
00 to 09	Measurement Point Status Indicates the operation of measurement points 1 to 10.																						
	<table border="1"> <thead> <tr> <th>bit</th> <th>09</th> <th>08</th> <th>07</th> <th>06</th> <th>05</th> <th>04</th> <th>03</th> <th>02</th> <th>01</th> <th>00</th> </tr> </thead> <tbody> <tr> <td>index</td> <td>10</td> <td>9</td> <td>8</td> <td>7</td> <td>6</td> <td>5</td> <td>4</td> <td>3</td> <td>2</td> <td>1</td> </tr> </tbody> </table>	bit	09	08	07	06	05	04	03	02	01	00	index	10	9	8	7	6	5	4	3	2	1
	bit	09	08	07	06	05	04	03	02	01	00												
index	10	9	8	7	6	5	4	3	2	1													
<p><b>0</b> = operational</p> <p><b>1</b> = non-operational</p> <p>'Non-operational' means that either the point is not configured or there is an error in the reading. Further information is available in the Point Alarm and Status words (Words 11 to 20).</p>																							
10	Operating Mode <b>0</b> = Siemens Milltronics SmartLinX instrument in <b>RUN</b> mode <b>1</b> = Siemens Milltronics SmartLinX instrument in <b>PROGRAM</b> mode																						
11 to 15	Reserved. (These bits are reserved and set to 0.)																						

## Words 1 to 10: Point Reading

These words contain the value of parameter P920 (Reading) for points 1 to 10, respectively. The reading is expressed as a percent of full scale, multiplied by 100, giving a range of -20,000 to 20,000 which corresponds to -200.00% to 200.00%. Refer to the Siemens Milltronics SmartLinx instrument documentation for a definition of "P920."

**Note:** These values may contain numeric level data for inoperative or malfunctioning points: refer to read word 0, and read words 11 to 20, for the actual operational status of the measurement points.

## Words 11 to 20: Point Alarm and Status

These words contain the corresponding alarm and status bits for indexed measurement points 1 to 10, respectively.

### Bit status:

0 = false

1 = true

Bit	description
00	point not configured
01	point failsafe timer expired
02	point failed (cable shorted, open, or transceiver problem)
03	point temperature sensor failed
04 to 12	reserved for future use
13	level emptying
14	level filling
15	scan mode priority

### If the product is an AiRanger/SITRANS LU Version 5.19 or above, only:

Bit	Description
04	Low-Low Alarm (1 = ON)
05	Low Alarm (1=ON)
06	High Alarm (1 = ON)
07	High-High Alarm (1 = ON)

These words contain values requested by writing to words 1 to 4 of the Write Block. The type of data and format are specified with that request, and returned in Read words 31 to 34.



## Words 31 and 32; 33 and 34: Decimal Place, Format, Parameter Number and Secondary Index, MPA

These words contain the last values written to Write block words 1 and 4. These words indicate what information is contained in Read block words 21 to 30. These words are provided since there can be a delay between writing a request via a Write, and the appearance of the requested values.

Use these words as an indicator that the requested information is updated.

## Words 35 to 37 and 39 to 41: Parameter Number/Primary Index/Secondary Index and Decimal Place/Format/Read Write Flag, SPA

These words contain the last values written to words 5 to 7 and 9 to 11 of the Write block. They confirm that the parameter value has been written. These words are not updated until the value has been successfully transferred and stored in the Siemens Milltronics SmartLinx instrument.

See Write formats on page 25 for details.

### Word 38: Returned Value, SPA

This word contains the current value of the parameter identified by words 35 to 37 and 39 to 40, regardless of the value of word 11 (Write flag).

If this value does not change when a new value is written to word 8 (Parameter Value) then check the following:

1. Words 5 to 7 and 9 to 10 of the Write block **should match** words 35 to 37 and 39 to 40 of the Read block: if not, then the instrument hasn't responded yet.
2. If words 5 to 7 and 9 to 10 of the Write block **do** match words 35 to 37 and 39 to 40, of the Read block, then the parameter value has not been updated. Check that the Siemens Milltronics SmartLinx instrument is in **PROGRAM** mode and that the program lock (P000) is not on, then try again.

# Data Map: Mass Dynamic Products

**Note:** The data maps shown for the Write and Read Blocks apply if P762 is set to the default values (see page 15). If any of these values is changed, the data map will be shortened and the configuration will change (see *Appendix A – Reducing the amount of data being transferred over the Bus*, on page 46).

This section describes the meaning of the data read from and written to the Siemens Milltronics SmartLinX instrument.

## Write Block

### BW500 and SF500

Description	Start	End	Size	Data Type
parameter number, SPA	0	0	1	integer
primary index, SPA	1	1	1	integer
secondary index, SPA	2	2	1	integer
new value, SPA	3	4	2	UINT32
decimal place, SPA	5	5	1	integer
format, SPA	6	6	1	integer
read/write flag, SPA	7	7	1	integer
command control	8	8	1	bitmapped
multispan selection	9	9	1	1-4
PID 1 setpoint value	10	11	2	UINT32
PID 2 setpoint value	12	13	2	UINT32
batch setpoint value	14	15	2	UINT32
batch prewarn setpoint value	16	17	2	UINT32
word order	18	18	1	0/1

**Note:**

- All the 32 bit numbers (except for the SPA numbers) have a fixed decimal place of 3 digits. For example PID 1 setpoint value of 3,245 is a value of 3.245 in the BW500 and the SF500.
- To make a change to any parameter in the BW500 or the SF500 using SmartLinX, P799 Communications Control must be set to 1.

<b>Description</b>	<b>Start</b>	<b>End</b>	<b>Size</b>	<b>Data Type</b>
parameter number, SPA	0	0	1	integer
primary index, SPA	1	1	1	integer
secondary index, SPA	2	2	1	integer
new value, SPA	3	4	2	UINT32
decimal place, SPA	5	5	1	integer
format, SPA	6	6	1	integer
read/write flag, SPA	7	7	1	integer
command control	8	8	1	bitmapped
word order	9	9	1	0/1

**Note:** To make a change to any parameter in the BW500/L using SmartLinX, P799 Communications Control must be set to 1.

**Parameter, SPA**

Specifies the parameter number for Single Parameter Access (SPA), see page 22.

**Primary Index, SPA**

Specifies the primary index number for the parameter specified by word 0.

**Secondary Index, SPA**

Specifies the secondary index for the parameter specified by word 0. This word is ignored for parameters that don't use multiple indexes.

**New Value, SPA**

The new value of the specified parameter and index.

**Decimal Place, SPA**

This word specifies the number of decimal places for the value in words 3 and 4. Positive values indicate that the decimal place shifts to the left, and negative values indicate that the decimal place shifts to the right.

For example:

word 5 = 1: all returned values have the decimal place shifted 1 space to the left and a returned value of 5,213 is interpreted as 521.3

word 5 = -1: a returned value of 5,213 is interpreted as 52,130

**Format, SPA**

This word is always set to 0.

**Read/Write Flag, SPA**

This word determines whether the instrument will allow parameter values to be written.

0 = Read

1 = Write

## Command Control, Operational Commands

The command control word is used to control the unit. Each bit gives access to a command or state as if the operator was using the keypad.

Bits initiating a command (6 to 11) must change state in order to cause the command to begin. For example, to reset totalizer 1, Bit 8 must be cleared to **0**, then set to **1**. It can stay set or clear for any period.

### BW500 and SF500

Bit #	Description	Bit Clear (0)	Bit Set (1)
00	PID 1 mode	manual	auto
01	PID 1 freeze	no	yes
02	PID 1 setpoint source	local	remote
03	PID 2 mode	manual	auto
04	PID 2 freeze	no	yes
05	PID 2 setpoint source	local	remote
06	zero	no change	start
07	span	no change	start
08	reset totalizer 1	no change	reset
09	reset totalizer 2	no change	reset
10	reset batch totalizer	no change	reset
11	print		print
12	reserved		
13	reserved		
14	reserved		
15	reserved		

### BW500/L

Bit #	Description	Bit Clear (0)	Bit Set (1)
06	zero	no change	start
07	span	no change	start
08	reset totalizer 1	no change	reset
09	reset totalizer 2	no change	reset
10	reserved		
11	print		print
12	reserved		
13	reserved		
14	reserved		
15	reserved		

### Bit 00 and 03: PID Mode (BW500 and SF500 only)

Sets the mode of PID control to either manual (output determined by P410 – PID Manual) or auto (output determined by PID control in instrument).

## **Bit 02 and 05 Setpoint Source (BW500 and SF500 only)**

Controls the location of the setpoint. If it is set as “local,” then the setpoint used is internal to the BW500 or SF500. If the setpoint source is set to “remote,” then the setpoint is controlled by a mA input.

For setpoint control through communications this must be set to “local.”

## **Bit 01 and 04: Freeze (BW500 and SF500 only)**

Suspends PID function when PID Mode = 1 (auto) and holds the output at the last value. PID functionality resumes when the freeze bit is cleared.

## **Bit 06: Zero**

Sets the zero point for calibration of the belt scale.

This is a momentary setting that must be reset to **0** once the input is accepted. To check that the input was accepted read word 0, bit 7 (zero status) and ensure it shows **1**. Once it shows a **1** then reset this bit to **0**

## **Bit 07: Span**

Sets the span for calibration of the belt scale.

This is a momentary setting that must be reset to **0** once the input is accepted. To check that the input has been accepted, read word 0, bit 8 (Span Status) and ensure it shows a **1**. Once it shows **1** then reset this bit to **0**.

## **Bit 08: Reset Totalizer 1**

Causes the internal totalizer 1 to be reset to **0**.

This is a momentary setting that must be reset to **0** once the input is accepted. To reset this back to **0**, the use of a timer is recommended.

## **Bit 09: Reset Totalizer 2**

Causes the internal totalizer 2 to be reset to **0**.

This is a momentary setting that must be reset to **0** once the input is accepted. To reset this back to **0**, the use of a timer is recommended.

## **Bit 10: Reset Batch Totalizer (BW500 and SF500 only)**

Causes the batch totalizer to be reset to **0**.

This is a momentary setting that must be reset to **0** once the input is accepted. To reset this back to **0**, the use of a timer is recommended.

## **Bit 11: Print**

Starts print operation. One of the communications ports on your Milltronics Integrator must be configured for a printer.

This is a momentary setting that must be reset to **0** once the input is accepted. To reset this back to **0**, the use of a timer is recommended.

## Multispan Selection (BW500 and SF500)

Sets the current span (1 to 4). Any parameters that relate to span will use this value to determine which span is referenced. See the manual for the BW500 or SF500 for more information on multispan.

## PID Setpoints (BW500 and SF500 only)

Contain the current setpoint values as P415 in the Milltronics BW500 or SF500.

To write these setpoints bits 02 and 05 in word 8 - Control must be set to "local."

## Batch Setpoint (BW500 and SF500 only)

Contain the current setpoint value as P564 in the Milltronics BW500 or SF500.

## Batch Prewarn Setpoint (BW500 and SF500 only)

Contain the current setpoint value as P567 in the Milltronics BW500 or SF500.

## Word Order

This word controls which word comes first in the UINT32 integers. For a value **0**, the most significant word is given first. For a value **1**, the least significant word is given first.

**0** = MSW first

**1** = LSW first

## Read Block

Values returned in the words in the Read are in response to the Write to the Siemens Milltronics SmartLinX instrument.

Words 0 through 20 have values with fixed meanings and formats. This means that you do not have to start communications with a Write in order to use Read, the data is always there.

Words 22 through 29 are values returned in response to writing words 0 through 7 for Single Parameter Access (SPA), see Write Block on page 30.

## BW500 and SF500

Description	Start	End	Size	Type
instrument status 1	0	0	1	bitmapped
rate	1	2	2	UINT32
load	3	4	2	UINT32
speed	5	6	2	UINT32
total 1	7	8	2	UINT32
total 2	9	10	2	UINT32
relay status	11	11	1	bitmapped
discrete input status	12	12	1	bitmapped
multispan selection	13	13	1	integer
PID 1 setpoint value	14	15	2	UINT32
PID 2 setpoint value	16	17	2	UINT32

Description	Start	End	Size	Type
batch setpoint value	18	19	2	UINT32
batch prewarn setpoint value	20	21	2	UINT32
parameter, SPA	22	22	1	integer
primary index, SPA	23	23	1	integer
secondary index, SPA	24	24	1	integer
new value, SPA	25	26	2	UINT32
decimal place, SPA	27	27	1	integer
format, SPA	28	28	1	integer
read / write flag, SPA	29	29	1	1/0
word order	30	30	1	1/0
Instrument Status 2 <sup>1</sup>	31	31	1	bitmapped
batch total <sup>1</sup>	32	33	2	UINT32

- <sup>1</sup> This is only available in firmware V 3.05 or higher. In V 3.05, these locations are "turned off" in P762. In higher firmware, they are defaulted on.

## BW500/L

Description	Start	End	Size	Type
instrument status 1	0	0	1	bitmapped
rate	1	2	2	UINT32
load	3	4	2	UINT32
speed	5	6	2	UINT32
total 1	7	8	2	UINT32
total 2	9	10	2	UINT32
relay status	11	11	1	bitmapped
discrete input status	12	12	1	bitmapped
parameter, SPA	13	13	1	integer
primary index, SPA	14	14	1	integer
secondary index, SPA	15	15	1	integer
new value, SPA	16	17	2	UINT32
decimal place, SPA	18	18	1	integer
format, SPA	19	19	1	integer
read / write flag, SPA	20	20	1	integer
word order	21	21	1	integer
Instrument Status 2 <sup>1</sup>	22	22	1	bitmapped

- <sup>1</sup> This is only available in firmware V 3.05 or higher. In V 3.05, these locations are "turned off" in P762. In higher firmware, they are defaulted on.

## Instrument Status 1

This word is used to feed back the current operating state of the product. Each bit gives the state of different parts of the product, some mutually exclusive, others are not. The state should be checked to verify operation.

### BW500 and SF500

Bit #	Description	Bit Clear (0)	Bit Set (1)
0	PID 1 mode	manual	auto
1	PID 1 freeze	no	yes
2	PID 1 setpoint source	local	remote
3	PID 2 mode	manual	auto
4	PID 2 freeze	no	yes
5	PID 2 setpoint source	local	remote
6	zero	no	in progress
7	span	no	in progress
8	reset totalizer 1	no change	reset
9	reset totalizer 2	no change	reset
10	reset batch totalizer	no change	reset
11	printing	not printing	printing
12	write privileges	no	yes
13	system configured	not configured	run mode
14	mode	calibration mode	run mode
15	totalizing	not totalizing	totalizing

### BW500/L

Bit #	Description	Bit Clear (0)	Bit Set (1)
6	zero	no	in progress
7	span	no	in progress
8	reset totalizer 1	no change	reset
9	reset totalizer 2	no change	reset
10	reserved		
11	printing	not printing	printing
12	write privileges	no	yes
13	system configured	not configured	run mode
14	mode	calibration mode	run mode
15	totalizing	not totalizing	totalizing

### Bits 0 to 5: PID Status (BW500 and SF500 only)

These bits give the status of the product. For example Bit 0 is the mode of the PID 1 controller (if used). It indicates whether the PID is in manual or auto modes.

### Bit 6: Zero Status

Indicates whether the unit is currently performing a Zero calibration.



**Bit 7: Span Status**

Indicates whether the unit is currently performing a Span calibration.

**Bits 8 to 11: Totalizer Status**

Indicate "1" if the reset totalizer or print operations are taking place (these are momentary and will only stay set for a very short period). (Note: Bit 10 applies only to BW500 and SF500.)

**Bit 12: Write Privileges**

Indicates whether the PLC can write parameters/commands to the product. This is controlled by parameter P799.

P799 = 1      PLC may change the Siemens Milltronics SmartLinX instrument's parameters  
 P799 = 0      PLC can only read

**Bit 13: Configuration Status**

Indicates whether the unit is configured (all required parameters have been entered).

**Bit 14: Program Mode**

Indicates program (calibration) mode:

0 = PROGRAM mode  
 1 = RUN mode

**Bit 15: Totalizing Status**

Indicates whether the unit is totalizing.

**Rate**

Contains the current rate reading in engineering units (For a full description of this reading, please refer to your Milltronics Integrator manual).

**Load**

Contains the current load reading in engineering units (For a full description of this reading, please refer to your Milltronics Integrator manual).

**Speed**

Contains the current speed reading in engineering units (For a full description of this reading, please refer to your Milltronics Integrator manual).

**Total 1<sup>1</sup>**

Contains the current value for totalizer 1 in engineering units (For a full description of this reading, please refer to your Milltronics Integrator manual).

<sup>1</sup> The number of fixed decimal places for this value is controlled by P634 primary indexes 1 and 2. The default setting is 3; see page 18 for details.

## Total 2<sup>1</sup>

Contains the current value for totalizer 2 in engineering units. (For a full description of this reading, please refer to your Milltronics Integrator manual).

## Relay Status

Shows the current logical status of all relays.

<b>bit</b>	04	03	02	01	00
<b>relay</b>	05	04	03	02	01

0 = relay not asserted

1 = relay asserted

“Asserted” indicates that the function controlling the relay is in an active state. Relay contacts can open or close based on this state, see your instrument manual for details.

## Discrete Input Status

Shows the current logical status of all discrete inputs.

<b>bit</b>	04	03	02	01	00
<b>input</b>	05	04	03	02	01

0 = discrete input open

1 = discrete input closed

## Multispan Selection (BW500 and SF500 only)

Shows the currently selected span (1 to 4).

## PID 1 Setpoint Value (BW500 and SF500 only)

Contains the current setpoint value for PID 1 in engineering units. (For a full description of this reading, please refer to your Milltronics Integrator manual).

## PID 2 Setpoint Value (BW500 and SF500 only)

Contains the current setpoint value for PID 2 in engineering units. (For a full description of this reading, please refer to your Milltronics Integrator manual).

## Batch Setpoint Value (BW500 and SF500 only)

Contains the value of P564 – Batch Setpoint. (For a full description of this parameter, please refer to your Milltronics Integrator manual).

## Batch Prewarn Setpoint Value (BW500 and SF500 only)

Contains the value of P567: Batch Prewarn Setpoint. (For a full description of this parameter, please refer to your Milltronics Integrator manual).

---

<sup>1</sup> The number of fixed decimal places for this value is controlled by P634 primary indexes 1 and 2. The default setting is 3; see page 18 for details.

## Parameter Number / Primary Index / Secondary Index, SPA; Decimal Place / Format / Read/Write flag, SPA

These words contain the last values written to words 0 to 2 and words 5 to 7 of the Write area. They confirm that the parameter value has been written. These words are not updated until the value has been successfully transferred and stored in the Siemens Milltronics SmartLinX instrument.

Use these words as an indicator that the requested information has been updated.

### Value, SPA

The returned value of the specified parameter and index.

### Word Order

The placement of the most significant word (MSW).

0 = MSW first

1 = MSW second

### Instrument Status 2

This word is used to feed back the current operating state of the product. Each bit gives the state of different parts of the product, some mutually exclusive, others are not. The state should be checked to verify operation.

Bit #	Description	Bit Clear (0)	Bit Set (1)
0	Totalizer 1 overflow	no overflow	overflow condition
1	Totalizer 2 overflow	no overflow	overflow condition

#### Bits 0 Totalizer 1 overflow

If Totalizer 1 has overflowed, (that is, has exceeded the spaces available in SmartLinX), this bit is set. The overflow condition can be changed by reducing Communication Totalizer resolution (P634).

#### Bit 1 Totalizer 2 overflow

If Totalizer 2 has overflowed, (that is, has exceeded the spaces available in SmartLinX), this bit is set. The overflow condition can be changed by reducing Communication Totalizer resolution (P634).

### Batch Totalizer (BW500 and SF500 only)

Contains the current value for the Batch Totalizer in engineering units. (For a full description of this reading, please refer to your Milltronics Integrator manual).

# Data Types

The Siemens Milltronics SmartLinX instrument parameters take on many values in various formats, as discussed in the Siemens Milltronics SmartLinX instrument manual. For the convenience of the programmer, those values are converted to and from 16-bit integer numbers, since those are easily handled by most PLCs.

## Integer

### Level Products

Integer parameter values are by far the most common. For example, parameter P920 (Reading) returns a number representing the current reading (either level or volume, depending on the Siemens Milltronics SmartLinX instrument configuration).

You can request numeric values in units or percent of span, and you can specify the number of decimal places.

Numeric values must be in the range  $-20,000$  to  $+20,000$  to be valid. If a parameter is requested and its value is more than  $+20,000$ , the number  $32,767$  is returned; if it is less than  $-20,000$ , the number  $-32,768$  is returned. If this happens, increase the number of decimal places for that parameter.

If a parameter cannot be expressed in terms of percent (e.g. span), or has no meaningful value, the special number  $22,222$  is returned. Try requesting the parameter in units, or refer to the Siemens Milltronics SmartLinX instrument manual to understand the format and use of the requested parameter.

### Mass Dynamics Products

Integers used on the Mass Dynamics products can have any valid value. So, the entire range from  $-32,768$  to  $32,767$  or  $0$  to  $65,535$  is available and no values are used as error conditions.

## Bit Values

Bits are packed into registers in groups of 16 bits (1 word). In this manual bits are numbered from 00 to 15, with bit 00 referring to the least significant bit and bit 15 referring to the most significant bit.

15	14	13	12	11	10	09	08	07	06	05	04	03	02	01	00
MSB															LSB

## Unsigned Double Precision Integer (UINT32)

**Note:** Used for Mass Dynamics products only.

Large numbers are put into unsigned 32-bit integers. By default they are set up so that the first word (register) is the most significant word (MSW) and the second word (register) is the least significant word (LSW) depending on the setting of the word order bit.

For example, when reading words 7 and 8 on the Mass Dynamics block (Total 1), the 32 bits would look as follows:

word 7			word 8		
15	MSW	0	15	LSW	0
31	32-bit integer value (UINT32)				0

The whole is read as a 32-bit integer.

## Split Values

**Note:** Used for Level products only

Certain parameters are actually a pair of numbers separated by a colon, in the format xx:yy.

**One example is P807, Transducer Noise, where:**

xx = the average noise value in dB.  
yy = the peak noise in dB.

The number which corresponds to xx:yy, either for reading or setting a parameter, is determined by the following formula:

**For storing to the Siemens Milltronics device:**

value =  $(xx + 128) \times 256 + (yy + 128)$

**For reading from the Siemens Milltronics device:**

xx =  $(\text{value} / 256) - 128$   
yy =  $(\text{value} \% 256) - 128$

**Where:**

% is the modulus operator.

The modulus can be computed by following these steps:

value<sub>1</sub> = value / 256  
value<sub>2</sub> = remainder of value<sub>1</sub>  
value<sub>3</sub> = value<sub>2</sub> x 256  
yy = value<sub>3</sub> - 128

**It may simplify programming to notice:**

xx = (most significant byte of value) – 128  
 yy = (least significant byte of value) – 128

## Text Messages

**Note:** Used for Level products only

If a Siemens Milltronics device parameter returns a text message, that message is converted to an integer and provided in the register. The numbers are shown in the table below:

Number	Text Message as displayed on LCD
22222	invalid value
30000	off
30001	on
30002	≡ ≡ ≡ ≡
30003	□ □ □ □ (parameter does not exist)
30004	err
30005	err1
30006	open
30007	shrt
30008	pass
30009	fail
30010	hold
30011	lo
30012	hi
30013	de
30014	en
30015	- - - - (parameter has not been set)
-32768	value is less than -20,000
32767	value is greater than 20,000

## Relay Function Codes (P111 in Level Products Only)

If a Siemens Milltronics instrument parameter returns a relay function code, that message is converted to a number and provided in the register. The numbers are shown in the table below.

See the Siemens Milltronics SmartLinX instrument manual for full information on P111.

Relay Function Code	Number	P111
off, relay not used	0	0
undesignated level alarm	1	1
low-low level alarm	2	1 – LL
low level alarm	3	1 – L
high level alarm	4	1 – H
high-high level alarm	5	1 – HH
in bounds alarm	6	2
in bounds alarm	7	2 – B1
in bounds alarm	8	2 – B2
out of bounds alarm	9	3
out of bounds alarm	10	3 – B1
out of bounds alarm	11	3 – B2
rate of level change alarm	12	4
rate of level change alarm	13	4 – R1
rate of level change alarm	14	4 – R2
temperature alarm	15	5
loss of echo (LOE) alarm	20	6
transducer cable fault alarm	16	7
pump efficiency alarm	17	8
clock failure alarm	18	9
time of day alarm	19	10
pump failure alarm	21	11
totalizer	22	40
flow sampler	23	41
fixed duty assist	25	50
fixed duty backup	26	51
alternate duty assist	30	52
alternate duty backup	31	53
service ratio duty assist	35	54
service ratio duty backup	36	55
first in first out (FIFO)	40	56
time	45	60
overflow	50	61
aeration	55	62
gate	60	63

<b>Relay Function Code</b>	<b>Number</b>	<b>P111</b>
flush valve	65	64
communication	66	65
pump failure alarm	70	11
power failure alarm	71	12
unknown function	200	



## Generally

In all cases, first check P794 and P795, to verify that you have the correct card for your device. Next check that the SmartLinX module has passed its on-going built-in self test (Siemens Milltronics SmartLinX instrument parameter P790). The result should be “pass.”

If “fail” is indicated, either the module is defective, or the module connector on the Siemens Milltronics SmartLinX instrument is defective.

If “err1” is indicated, the Siemens Milltronics software doesn’t recognize the ID number of the installed module. Please contact Siemens Milltronics or your distributor for instructions and/or upgraded Siemens Milltronics SmartLinX instrument software.

Make sure the Siemens Milltronics device is set to a unique address, and does not conflict with any other slave(s) on the bus.

Check the configuration of the scanning master, and make sure it is functioning properly.

**1. If you have configured the Siemens Milltronics device in the Master and downloaded it to the processor, but the device is not coming online:**

- Check which GSD file you use, and make sure you used the correct one (see *GSD Files* on page 13).
- Check the wiring to the card. In particular, check that you have line A and B connected correctly.
- Verify that you set the correct address on the card. Also, please note that the card does not see a charge until the power has been cycled.
- Verify that the Read and Write Block sizes are correct. This is particularly important if you are using P762.

**2. If the network was working fine until you connected to the Siemens Milltronics device, at which time other devices dropped out:**

- Check the termination switch on the PROFIBUS card. The network cable has to be terminated at both ends of the LAN, but not in between.
- Check your grounding. The PROFIBUS specifications require that all devices be on the same ground. Improper grounding can cause strange effects.

## Technical Support or Product Feedback

For product feedback or technical support, please contact your local Siemens Milltronics representative or e-mail us at [www.siemens.com/automation/support-request](http://www.siemens.com/automation/support-request).

# Appendix A – Reducing the amount of data being transferred over the Bus

You can limit the amount of data being transferred over the Bus, and save both bandwidth and memory, by using P762. However, when you reduce the size of the data map, the configuration will change. If the data block sizes in the device do not match what is configured in the master, no communications will occur. Therefore it is critical to calculate the size of the new map. The calculation is different for level applications and for mass dynamics applications.

The following sections provide explanations and examples of the calculation required, together with a worksheet to use as a template. The first section explains how it works with level products, and the second explains how it works with mass dynamics products. In each section, the Write Block map is calculated first, followed by the Read Block.

## Level Products

The SmartLinx map<sup>1</sup> is controlled by the values of the indices of P762. By turning on an index (setting the value to one or more), you activate both the read and write blocks associated with that index. The table below shows which values in the read/write blocks are turned on by each P762 index.

Name of area	P762 Point	Value	Read area turned On	Write area turned on
Status	1	1	Instrument status	-----
Reading	2	1 -10	1-10 point readings	-----
Alarm	3	1-10	1-10 point alarm and status	-----
Point-on-priority	4	1	-----	Measurement point-on-priority
MPA	5	1	Returned Values (1-10)	Parameter number
			Decimal place	Secondary index
			Format	Decimal place
			Parameter number	Format
			Secondary index	-----

<sup>1</sup> For examples of the data maps before modification, see pages 49 and 51.

SPA	6	1	Parameter Number	Parameter Number
			Primary index	Primary index
			Secondary index	Secondary index
			Returned Value	New Value
			Decimal Place	Decimal Place
			Format	Format
			Read/Write	Read/ Write
Operating Mode	7	1	-----	Operating Mode

## Write Block

The standard Write block is made up of the following sections: point-on-priority, MPA, SPA, and operating mode. If any of these sections is 'turned off' by setting the corresponding part of P762 to a zero, the new map will shift down accordingly and the size will be reduced by that amount. Multiply the parameter value by the memory size, then add up the results to get the total.

### Write Block Template for Level Products

Name of area	P762 Point	value	Memory size for Write block per value	Result of multiplying value * memory size
Status	1		0	
Reading	2		0	
Alarm	3		0	
Point-on-priority	4		1	
MPA	5		4	
SPA	6		7	
Operating mode	7		1	
			Total words:	

### Example 1:

If you want only Point status, and to read the first 7 point readings, the chart is:

Name of area	P762 Point	value	Memory size for Write block per value	value * memory size
Status	1	1	0	0
Reading	2	7	0	0
Alarm	3	0	0	0
Point-on - priority	4	0	1	0
MPA	5	0	4	0
SPA	6	0	7	0
Operating mode	7	0	1	0
			Total words:	0

The output data block (Write block) is now 0 words in size (0 bytes).

### No map

### Example 2:

If you want only SPA, then the chart is:

Name of area	P762 Point	value	Memory size for Write block per value	value * memory size
Status	1	0	0	0
Reading	2	0	0	0
Alarm	3	0	0	0
Point-on - priority	4	0	1	0
MPA	5	0	4	0
SPA	6	1	7	7
Operating mode	7	0	1	0
			Total words:	7

The output data block (Write block) is now 7 words in size (14 bytes) and the Word numbers have shifted to a lower value

### New Write Block Data Map

Word	Description
0	Parameter number
1	Parameter primary index
2	Parameter secondary index
3	Parameter value
4	Decimal place
5	Format
6	Read / Write flag

## Original Write Block Data Map for Level Products

Words	Description	Access	Data Type
0	measurement point-on-priority	direct	bitmapped
1	parameter number	MPA	integer
2	parameter secondary index <sup>1</sup>		integer
3	decimal place		integer
4	format		0/1
5	parameter number	SPA	integer
6	parameter primary index		integer
7	parameter secondary index		integer
8	parameter value		integer
9	decimal place		integer
10	format		0/1
11	read/write flag		0/1
12	operating mode	direct	0/1

1. The primary index is implicit in the address of the returned parameter values.

## Read Block

The standard Read block is made up of the following sections: status, reading, alarm, MPA, and SPA. If any of these sections is 'turned off' by setting the corresponding part of P762 to a zero, the new map will shift down accordingly and the size will be reduced by that amount for the Read block. Multiply the parameter value by the memory size, then add up the results to get the total.

### Read Block Template for Level Products

Name of area	P762 Point	value	Memory size for Read block per value	Result of multiplying value * memory size
Status	1		1	
Reading	2		1	
Alarm	3		1	
Point-on-priority	4		0	
MPA	5		14	
SPA	6		7	
Operating mode	7		0	
			Total Words:	

### Example 1:

If you want only Instrument status, and to read the first 7 point readings, then the chart is:

Name of area	P762 Point	value	Memory size for Read block per value	value * memory size
Status	1	1	1	1
Reading	2	7	1	7
Alarm	3	0	1	0
Point-on-priority	4	0	0	0
MPA	5	0	14	0
SPA	6	0	7	0
Operating mode	7	0	0	0
			Total words:	8

The input data block (Read block) is now 8 words in size (16 bytes), and the Word numbers have shifted to a lower value.

### New Read Block Data map:

Word	Description
0	Instrument status
1	Reading for point 1
2	Reading for point 2
3	Reading for point 3
4	Reading for point 4
5	Reading for point 5
6	Reading for point 6
7	Reading for point 7

### Example 2:

If you want only SPA, then the chart is:

Name of area	P762 Point	value	Memory size for Read block per value	value * memory size
Status	1	0	1	0
Reading	2	0	1	0
Alarm	3	0	1	0
Point-on-priority	4	0	0	0
MPA	5	0	14	0
SPA	6	1	7	7
Operating mode	7	0	0	0
			Total words:	7

The input data block (Read block) is now 7 words in size (14 bytes), and the Word numbers have shifted to a lower value.

### New Read Block Data map:

Word	Description
0	Parameter number
1	Parameter primary index
2	Parameter secondary index
3	Parameter returned value
4	Decimal place
5	Format
6	Read/Write flag

## Original Read Block Data map for Level Products

Words	Description	Access	Data Type
0	instrument status		bitmapped
1-10	point reading	direct	integer
11-20	point alarm and status		bitmapped
21-30	returned values		integer
31	decimal place		integer
32	format	MPA	0/1
33	parameter number		integer
34	parameter secondary index		integer
35	parameter		integer
36	parameter primary index		integer
37	parameter secondary index		integer
38	value	SPA	integer
39	decimal place		integer
40	format		0/1
41	read/write flag		0/1

## Mass Dynamics Products

The SmartLinx map<sup>1</sup> is controlled by the values of the indices of P762. By turning on an index (setting the value to one or more), you activate both the read and write blocks associated with that index. The table below shows which values in the read/write blocks are turned on by each P762 index.

Name of area	P762 Point	Value		Read area turned On	Write area turned on
		BW500, SF500	BW500/L		
status	1	1	1	instrument status	-----
rate	2	1	1	rate	-----
load	3	1	1	load	-----
speed	4	1	1	speed	-----
total	5	1	1	total 1	-----
				total 2	
relay status	6	1	1	relay status	-----
DI status	7	1	1	discrete input status	-----

<sup>1</sup> For examples of the data maps before modification, see pages 54 and 55

SPA	8	1	1	parameter number	parameter number
				primary index	primary index
				secondary index	secondary index
				returned value	new value
				decimal place	decimal place
				format	format
read/write	read/ write				
command control	9	1	1	-----	command control
multispan	10	1	0 <sup>1</sup>	-----	multispan selection
PID	11	1	0 <sup>1</sup>	-----	PID 1 setpoint value
				-----	PID 2 setpoint value
batch	12	1	0 <sup>1</sup>	-----	batch setpoint value
batch prewarn	13	1	0 <sup>1</sup>	-----	batch prewarn setpoint value
word order	14	1	1	word order	word order
status 2	15	1	1	instrument status 2	-----
batch total	16	1	0 <sup>1</sup>	batch total	-----

1. For the BW500/L, P762 indexes with values shown as 0 cannot be turned on.

## Write Block

The standard Write block is made up of the following sections: SPA, command control, multispan, PID, batch, batch prewarn, word order. If any of these sections is 'turned off' by setting the corresponding part of P762 to a zero, the new map will shift down accordingly and the size will be reduced by that amount. Multiply the parameter value by the memory size, then add up the results to get the total

### Write Block Template for Mass Dynamic Products

Name of area	P762 Point	value	Memory size for Write block per value	Result of multiplying value * memory size
status	1		0	
rate	2		0	
load	3		0	
speed	4		0	
total	5		0	
relay status	6		0	



Name of area	P762 Point	value	Memory size for Write block per value	Result of multiplying value * memory size
DI status	7		0	
SPA	8		8	
command control	9		1	
multispan	10		1	
PID	11		4	
batch	12		2	
batch prewarn	13		2	
word order	14		1	
status 2	15		0	
batch total	16		0	
			total words:	

### Example 1:

If you want only rate, load, and batch prewarn, then the chart is:

Name of area	P762 Point	value	Memory size for Write block per value	value * memory size
status	1	0	0	0
rate	2	1	0	0
load	3	1	0	0
speed	4	0	0	0
total	5	0	0	0
relay status	6	0	0	0
DI status	7	0	0	0
SPA	8	0	8	0
command control	9	0	1	0
multispan	10	0	1	0
PID	11	0	4	0
batch	12	0	2	0
batch prewarn	13	1	2	2
word order	14	0	1	0
status 2	15	0	0	0
batch total	16	0	0	0
			total words:	2

The input data block (Write block) is now 2 words in size (4 bytes) and the Word numbers have shifted to a lower value:

### New Write Block Data Map:

Word	Description
0-1	Batch prewarn

## Original Write Block Data Map for Mass Dynamic Products

Description	Start	End	Size	Data Type
parameter number, SPA	0	0	1	integer
primary index, SPA	1	1	1	integer
secondary index, SPA	2	2	1	integer
value, SPA	3	4	2	UINT32
decimal place, SPA	5	5	1	integer
format, SPA	6	6	1	integer
read / write flag, SPA	7	7	1	integer
command control	8	8	1	bitmapped
multispan selection	9	9	1	1-4
PID 1 setpoint value	10	11	2	UINT32
PID 2 setpoint value	12	13	2	UINT32
batch setpoint value	14	15	2	UINT32
batch prewarn setpoint value	16	17	2	UINT32
word order	18	18	1	0/1

## Read Block

The standard Read block is made up of the following sections: status, rate, load, speed, total, relay status, DI status, multispan, PID, batch, batch prewarn, SPA, word order. If any of these sections is 'turned off' by setting the corresponding part of P762 to a zero, the new map will shift down accordingly and the size will be reduced by that amount, for the Read block. Multiply the parameter value by the memory size, then add up the results to get the total.

### Read Block Template for Mass Dynamic Products

Name of area	P762 Point	value	Memory size for Read block per value	Result of multiplying value * memory size
status	1		1	
rate	2		2	
load	3		2	
speed	4		2	
total	5		4	
relay status	6		1	
DI status	7		1	
SPA	8		8	
command control	9		0	
multispan	10		1	
PID	11		4	
batch	12		2	
batch prewarn	13		2	

word order	14		1	
status 2	15		1	
batch total	16		2	
			Total words:	

### Example 1

If you want only rate, load, and batch prewarn, the chart is:

Name of area	P762 Point	value	Memory size for Read block per value	value * memory size
status	1	0	1	0
rate	2	1	2	2
load	3	1	2	2
speed	4	0	2	0
total	5	0	4	0
relay status	6	0	1	0
DI status	7	0	1	0
SPA	8	0	8	0
command control	9	0	0	0
multispan	10	0	1	0
PID	11	0	4	0
batch	12	0	2	0
batch prewarn	13	1	2	2
word order	14	0	1	0
status 2	15	0	1	0
batch total	16	0	2	0
			<b>total words:</b>	<b>6</b>

The input data block (Read block) is now 6 words in size (12 bytes) and the Word numbers have shifted to a lower value:

#### New Read Block Data Map

Word	Description
0-1	rate
2-3	load
4-5	batch prewarn

#### Original Read Block Data Map for Mass Dynamic Products

Description	Start	End	Size	Type
instrument status	0	0	1	bitmapped
rate	1	2	2	UINT32
load	3	4	2	UINT32
speed	5	6	2	UINT32
total 1	7	8	2	UINT32

Description	Start	End	Size	Type
total 2	9	10	2	UINT32
relay status	11	11	1	bitmapped
discrete input status	12	12	1	bitmapped
multispan selection	13	13	1	integer
PID 1 setpoint value	14	15	2	UINT32
PID 2 setpoint value	16	17	2	UINT32
batch setpoint value	18	19	2	UINT32
batch prewarn setpoint value	20	21	2	UINT32
parameter, SPA	22	22	1	integer
primary index, SPA	23	23	1	integer
secondary index, SPA	24	24	1	integer
value, SPA	25	26	2	UINT32
decimal place, SPA	27	27	1	integer
format, SPA	28	28	1	integer
read / write flag, SPA	29	29	1	1/0
word order	30	30	1	1/0
instrument status 2 <sup>1</sup>	31	31	1	bitmapped
batch total <sup>1</sup>	32	33	2	UINT32

<sup>1</sup> This is only available in firmware V 3.05 or higher

# Index

---

## A

- AiRanger Series
  - connection 8
  - operation 11

- Alarm and Status 28
- Application Layer 19

## B

- Batch Prewarn Setpoint 34
- Batch Pre-Warn Setpoint Value 38
- Batch Setpoint 34
- Batch Setpoint Value 38
- Baud Rate 13
- Bit Values 40
- Bus Address 13

## C

- Cable
  - connector 8
  - routing 7
- Command Control, Operational Commands 32
- Communication Setup 13
- Communication Speed 13
- Compatibility 5
- Compatible Instruments 4
- Configuration
  - files 13
  - slave device 14
- Configuration Status 37
- CraneRanger
  - connection 8
  - operation 11

## D

- Data Access Methods 20
- Data Map
  - level products 24
  - mass dynamics products 30
- Data Types 40
  - Bit Values 40
  - integer 40
  - mass dynamic products 40
  - Numeric 40
  - P111 Values 43
  - Split Values 41
  - text messages 42
  - UIN32 41
- Decimal Place 25, 26, 29, 31
- Direct Access 20

- Discrete Input Status 38

## E

- EnviroRanger ERS 500
  - Operation 11, 12
- EnviroRanger ERS 500 (rack and panel)
  - connection 9
- EnviroRanger ERS 500 (wall mount)
  - connection 9
- Error Conditions 12
- Error Status LED's 11

## F

- Flag 29
- Format 25, 26, 29, 31
- Freeze 33

## G

- GSD Files 13

## I

- Index 29
  - alarm and status 28
  - direct access 20
  - MPA 21
  - point reading 28
  - primary 19
  - secondary 20
- Indexed Parameters 19
- Installation 5
- Instrument
  - compatibility 5
- Instrument Status 36
- Integer 40
- InterRanger DPS 300
  - connection 8
  - operation 11

## L

- LED's
  - Error state 11
- LEDs 11
- level products
  - data map 24
- Load 37

## M

- manual 1
  - overview 1
- Mark 20
- Mass Dynamics
  - data map 30
- Master Reset 22
- Measurement Point Status 27
- Milltronics BW 500
  - connection 9

- Milltronics BW500
  - Operation 11, 12
- MPA
  - overview 21
  - parameter indexing 21
  - using 21
- Multiple Parameter Access 20, 21
- Multispan Selection 34, 38
- N**
- Network Address 13
- Numeric Values 40
- O**
- Operating Mode 26
- Operation 11
- Operation LED 12
- P**
- P999 22
- Parameter 25, 31
- Parameter Indexes 19
- parameter indexing 22
- Parameter Number 25, 29, 39
- Parameter Number and Secondary Index 29
- Parameter Secondary Index 25
- PID 1 Setpoint Value 38
- PID Mode 32
- PID Setpoints 34
- PID Status 36, 39
- Point 19, 29
- Point Alarm and Status 28
- Point Reading 28
- Point-on-Priority 24
- Primary Index 19, 25, 31, 39
- Print 33
- Print Status 37
- Program Mode 37
- R**
- Rate 37
- Read
  - level products 27
  - mass dynamics products 34
- Read/Write Flag 26
- Reading 28
  - MPA 21
  - SPA 22
- Relay Function Codes 43
- Relay Status 38
- Returned Values 28
- S**
- Secondary Index 20, 25, 31, 39
- Setpoint Source 33
- Setup
  - communication 13
- Single Parameter Access 22
- SmartLinx® Profibus DP 1
- SPA
  - overview 22
  - reading 22
  - using 22
  - writing 23
- Span 33
- Span Status 37
- Specifications 4
- Speed 37
- Split Values 41
- Status 11
- T**
- target audience 1
- Terminal Block
  - connector 8
- Termination Switch 10
- Text Messages 42
- Total 1 37
- Total 2 38
- Totalizer Reset 33
- Totalizer Status 37
- Totalizing Status 37
- Troubleshooting 45
- U**
- UINT32 41
- Unsigned Double Precision Integer 41
- Using
  - MPA 21
  - SPA 22
- V**
- Value 26, 29, 31, 39
- W**
- Wiring
  - connector 8
- Word Order 39
- Write
  - level products 24
  - mass dynamics products 30, 31
- Write Privileges 37
- Writing 23
- Z**
- Zero 33
- Zero Status 36

## For more information

[www.siemens.com/level](http://www.siemens.com/level)

[www.siemens.com/weighing](http://www.siemens.com/weighing)

Siemens AG  
Industry Sector  
1954 Technology Drive  
P.O. Box 4225  
Peterborough, ON  
Canada K9J 7B1

email: [techpubs.smpi@siemens.com](mailto:techpubs.smpi@siemens.com)

[www.siemens.com/processautomation](http://www.siemens.com/processautomation)

Subject to change without prior notice  
7ML19981AQ03 Rev. 3.3

© Siemens AG 2011



7 M L 1 9 9 8 1 A Q 0 3  
Printed in Canada