

Instruction Manual • February 2003

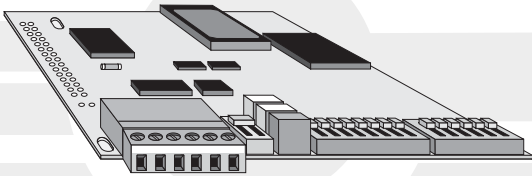

# smartlinx interface module

---

## DEVICENET

**MILLTRONICS**

## Safety Guidelines

Warning notices must be observed to ensure personal safety as well as that of others, and to protect the product and the connected equipment. These warning notices are accompanied by a clarification of the level of caution to be observed.

## Qualified Personnel

This device/system may only be set up and operated in conjunction with this manual. Qualified personnel are only authorized to install and operate this equipment in accordance with established safety practices and standards.

**Warning:** This product can only function properly and safely if it is correctly transported, stored, installed, set up, operated, and maintained.

**Note:** Always use product in accordance with specifications.

**Copyright Siemens Milltronics Process Instruments Inc. 2003. All Rights Reserved**

**Disclaimer of Liability**

This document is available in bound version and in electronic version. We encourage users to purchase authorized bound manuals, or to view electronic versions as designed and authored by Siemens Milltronics Process Instruments Inc. Siemens Milltronics Process Instruments Inc. will not be responsible for the contents of partial or whole reproductions of either bound or electronic versions.

While we have verified the contents of this manual for agreement with the instrumentation described, variations remain possible. Thus we cannot guarantee full agreement. The contents of this manual are regularly reviewed and corrections are included in subsequent editions. We welcome all suggestions for improvement.

Technical data subject to change.

MILLTRONICS® is a registered trademark of Siemens Milltronics Process Instruments Inc.

Contact SMPI Technical Publications at the following address:

Technical Publications  
Siemens Milltronics Process Instruments Inc.  
1954 Technology Drive, P.O. Box 4225  
Peterborough, Ontario, Canada, K9J 7B1  
Email: [techpubs@milltronics.com](mailto:techpubs@milltronics.com)

For the library of SMPI instruction manuals, visit our Web site: [www.milltronics.com](http://www.milltronics.com)

# Table of Contents

---

<b>SmartLinX Device Net</b> .....	<b>1</b>
Technical Support and Product Feedback .....	1
Safety Notes .....	2
The Manual .....	2
<b>Specifications</b> .....	<b>3</b>
<b>Installation</b> .....	<b>4</b>
Compatibility .....	4
Software Compatibility .....	4
Hardware Compatibility .....	5
DIP Switches .....	7
Cable Connector .....	7
<b>Operation</b> .....	<b>9</b>
Error Status LEDs .....	9
Operation LED .....	10
<b>Communication Set-up</b> .....	<b>11</b>
EDS Files .....	12
Sample Code .....	12
Communications Parameters .....	13
Map Element Selection .....	13
Module Identification .....	15
P634: Communication Totalizer Resolution .....	16
<b>Application Layer</b> .....	<b>17</b>
Parameter Indexes .....	17
Primary Index .....	17
Secondary Index .....	18
Data Access Methods .....	18
Direct Access .....	19
Multiple Parameter Access (MPA) .....	19
Single Parameter Access (SPA) .....	20
Data Map 1: AiRanger series, CraneRanger series, and InterRanger DPS 300 .....	21
Write Block .....	21
Read Block .....	24
Data Map 2: EnviroRanger ERS 500, MultiRanger 100/200, HydroRanger 200 .....	27
Write Block .....	27
Read Block .....	30
Data Map 3: Milltronics BW500 and Milltronics SF500 .....	33
Write Block .....	33
Read Block .....	37
Data Types .....	42
Integer .....	42
Bit Values .....	42
Unsigned Double Precision Integer (UINT32) .....	43
Split Values .....	43

Text Messages .....	44
Relay Function Codes (P111 in Level Products Only) .....	45
<b>Troubleshooting .....</b>	<b>47</b>
Generally .....	47
Specifically .....	47
Technical Support or Product Feedback .....	47
<b>Appendix A – Reducing the amount of data being transferred over the Bus .....</b>	<b>48</b>
Level Products .....	48
Write Block .....	49
Read Block .....	51
Mass Dynamics Products .....	53
Write Block .....	54
Read Block .....	56
<b>Index .....</b>	<b>60</b>

# SmartLinX Device Net

The Siemens Milltronics SmartLinX<sup>1</sup> DeviceNet module is a plug-in communications card designed to interface a Siemens Milltronics SmartLinX-compatible instrument to a DeviceNet network.

Only those instruments which support the DeviceNet protocol can use this card. See *Compatibility* on page 4 for a list of compatible Siemens Milltronics SmartLinX instruments.

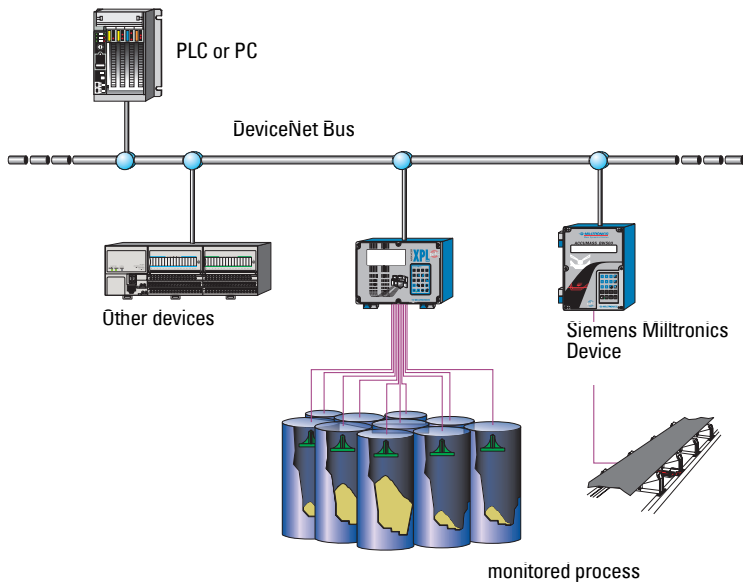

DeviceNet is an open standard controlled by the Open DeviceNet Vendors Association (ODVA). More information is available at the web site [www.odva.org](http://www.odva.org).

**Note:**

Siemens Milltronics does not own the DeviceNet protocol. All information regarding that protocol is subject to change without notice.

## Technical Support and Product Feedback

For product feedback or technical support, please contact your local Siemens Milltronics representative or e-mail us at [SmartLinX@siemens-milltronics.com](mailto:SmartLinX@siemens-milltronics.com)

<sup>1</sup> SmartLinX<sup>®</sup> is a registered trademark of Siemens Milltronics Process Instruments Inc.

# Safety Notes

Special attention must be paid to warnings and notes highlighted from the rest of the text by grey boxes.

**!** **WARNING:** means that failure to observe the necessary precautions can result in death, serious injury, and/or considerable material damage.

**CAUTION:** means that failure to observe the necessary precautions can result in considerable material damage.

**Note:** means important information about the product or that part of the operating manual.

## The Manual

### Notes:

- Please follow the installation and operating procedures for a quick, trouble-free installation and to ensure the maximum accuracy and reliability of your Siemens Milltronics SmartLinx DeviceNet module.
- This manual applies to SmartLinx DeviceNet only.

This manual will help you install and connect a Siemens Milltronics SmartLinx<sup>®</sup> DeviceNet module and set it up for communication within a DeviceNet network. The manual is targeted at a technical audience in the industrial communications field with a sound working knowledge of DeviceNet.

We always welcome questions, comments, or suggestions about manual content, design, and accessibility.

Please direct your questions or comments to [techpubs@siemens-milltronics.com](mailto:techpubs@siemens-milltronics.com). For the complete library of Siemens Milltronics manuals, go to [www.siemens-milltronics.com](http://www.siemens-milltronics.com).

# Specifications

---

## Application

- compatible with a master instrument on a REV. 2.00 DeviceNet bus

## Compatible Instruments

- AiRanger XPL Plus / SITRANS LU 10
- AiRanger DPL Plus / SITRANS LU 02
- AiRanger SPL / SITRANS LU 01
- InterRanger DPS 300
- EnviroRanger ERS 500
- Milltronics BW500
- Milltronics SF500
- MultiRanger 100/200
- HydroRanger 200

## Communication Settings (parameter defined)

baud rate:

- 125 Kbps, 250 Kbps, or 500 Kbps

network address:

- 0 to 63

## Connection

- terminal block

## Termination

- external  $121\ \Omega$   $\frac{1}{4}$  W resistor required at far ends of the LAN.

## Cable:

- as per DeviceNet specification, REV. 2.00

## Load / Draw

- from bus power: less than 70 mA

# Installation

The SmartLinX module is either shipped installed in the Siemens Milltronics instrument or shipped separately for on-site installation. Refer to the manual of your Siemens Milltronics instrument for details on module location and installation.

## Compatibility

For the SmartLinX Device Net card there are different hardware and software configurations available depending on the equipment used.

## Software Compatibility

If a device is SmartLinX ready, it will work with the correct SmartLinX card for that device. However, if the firmware version is a lower number than the one listed below, the P762 Map Element Selection Parameter will not be available. Also, for the BW500 and the SF500, the read block will be a smaller size.

Product	Software Rev.	Product	Software Rev.
AiRanger XPL Plus / SITRANS LU 10	5.23	Milltronics SF500	3.05
AiRanger DPL Plus / SITRANS LU 02		Milltronics BW500	
AiRanger SPL / SITRANS LU 01		MultiRanger 100	1.04
InterRanger DPS 300		MultiRanger 200	1.03
	HydroRanger 200		
		EnviroRanger ERS 500	5.06

## Retrofits

If you are replacing an older SmartLinX device with a new SmartLinX device, and you are using any product other than the BW500 or SF500, then you can use the default values for P762.

If you are replacing a BW500 or SF500 with a new device, then set P762 primary index 15 = 0, and P762 primary index 16 = 0.



# Hardware Compatibility

All available SmartLinX DeviceNet card configurations are shown here for reference.

**The card shown below is compatible with the following Siemens Milltronics units:**

- AiRanger XPL Plus / SITRANS LU 10
- AiRanger DPL Plus / SITRANS LU 02
- AiRanger SPL / SITRANS LU 01
- InterRanger DPS 300

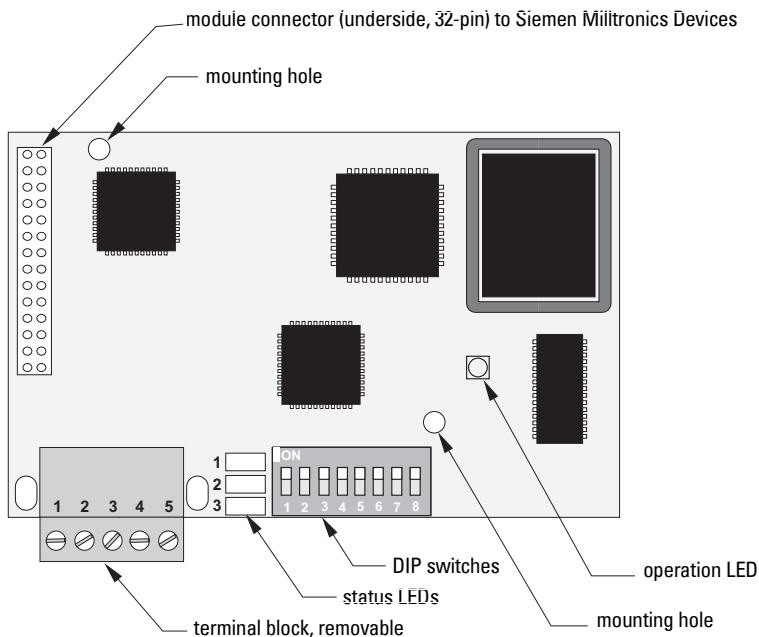

**The card shown below is compatible with the following Siemens Milltronics units**

- Milltronics BW500
- Milltronics SF500
- EnviroRanger ERS 500 (Wall Mount)
- HydroRanger 200
- MultiRanger 100/200

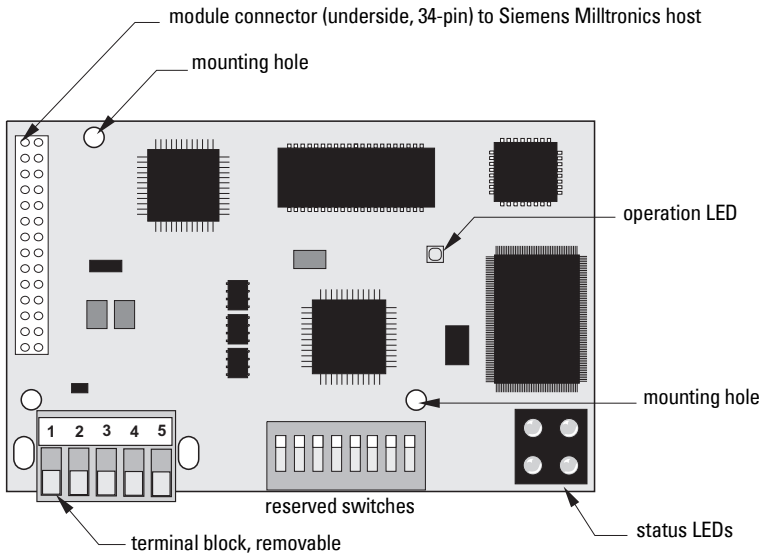

**The card shown below is compatible with the EnviroRanger Rack or Panel Mount**

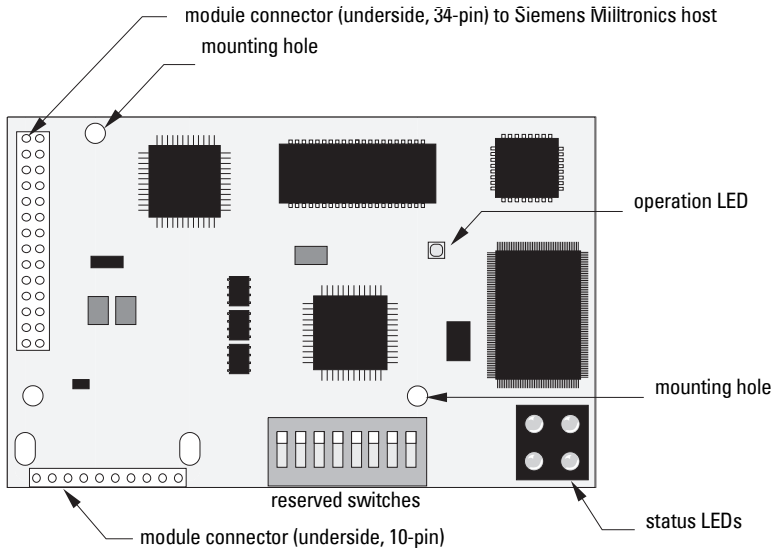

installation

### Notes:

- Install the SmartLinX card so that the mounting holes align and the pin connectors mate correctly
- Correct cable routing is important for electromagnetic noise suppression. Follow the routing instructions contained in the unit's instruction manual.

## DIP Switches

Refer to the following diagram to view the DIP switches. DIP Switches 1 to 8 must be in the ON position to allow the selection of Media Access Control (MAC) ID and data rate.

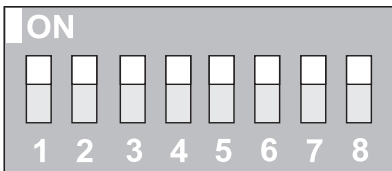

## Cable Connector

**AiRanger / SITRANS LU Series, CraneRanger, InterRanger DPS 300, EnviroRanger ERS 500 (Wall Mount), MultiRanger 100/200, HydroRanger 200, Milltronics BW500, and Milltronics SF500,**

Connect the DeviceNet card using cable which conforms to DeviceNet specifications and terminate according to the network requirements.

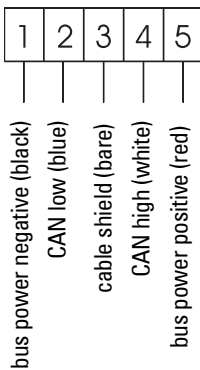

## EnviroRanger ERS 500 (Rack or Panel Mount)

When using a SmartLinX card with the EnviroRanger (Rack or Panel) all wiring is made to the EnviroRanger terminal board. The DeviceNet connections map to the EnviroRanger terminal board as shown:

DeviceNet	ERS Rack or Panel
CAN Low (blue)	66
CAN HIGH (white)	68
V- BUS (black)	69
V+ BUS (red)	71
SHLLD (bare)	73

# Operation

Communication on the DeviceNet network is indicated by the SmartLinX LED's.

## Error Status LEDs

**AiRanger / SITRANS LU Series, CraneRanger, InterRanger DPS 300.**

Refer to the following diagram to view the error status LEDs. There are three LEDs on the DeviceNet circuit card. LED 1 is furthest from the card's edge, LED 2 is in the centre and LED 3 is closest to the edge.

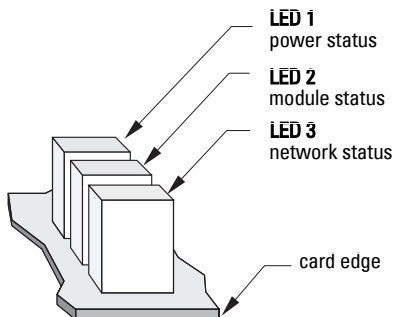

LED	Status of:	Condition	Indication
1	Power	Flashing green	Module is initializing
		Solid green	Module is ready
2	Module	Flashing green	Module is configuring
		Solid green	Module is configured
		Flashing red	Recoverable fault
		Solid red	Critical fault
3	Network	Flashing green	On-line but not connected
		Solid green	On-line and serviceable link
		Flashing red	Recoverable fault

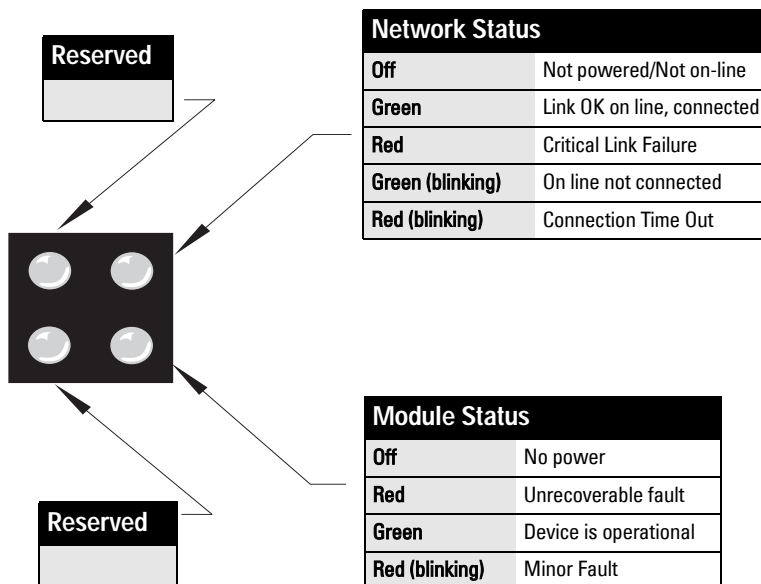

## Operation LED

The operation LED flashes green during normal operation. If the LED does not flash green the module is not operating.

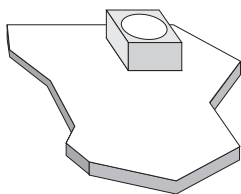

### LED

- blinks orange as the module is initialized
- blinks green during normal operation

**Note:** The location of the Operation LED varies depending on the card that you are using. Refer to the diagrams in the *Installation* section that starts on page 4 for its appropriate location.

# Communication Set-up

---

The SmartLinx DeviceNet module is a slave device on the network. It is a DeviceNet Group 2 server only as determined in the predefined master/slave connection definitions.

The data size of the input and output modules is dependent on P762, and on the type of unit the module is plugged into (see the three categories below). The following instructions assume that P762 is set to the default values shown in the chart on page 13.

There are three categories of device:

1. AiRanger/ SITRANS LU Series, CraneRanger series, and InterRanger DPS 300
2. EnviroRanger ERS 500, MultiRanger 100/200, HydroRanger 200
3. Milltronics BW500, Milltronics SF500

## AiRanger / SITRANS LU Series, CraneRanger and InterRanger DPS 300

This card only supports polled I/O with the following setup:

- I/O connection #1 input size of 64 bytes.
- I/O connection #1 output size of 26 bytes.

Some configurations may also require some of the following information:

- Device Type is 12(0x0c)
- Product code is 7
- Vendor ID is 90 (0x5a)

## EnviroRanger ERS 500, MultiRanger 100/200, HydroRanger 200

This card only supports polled I/O with the following setup:

- I/O connection #1 input size of 84 bytes.
- I/O connection #1 output size of 26 bytes.

Some configurations may also require some of the following information:

- Device Type is 12(0x0c)
- Product code is 12
- Vendor ID is 90 (0x5a)

## Milltronics BW500, Milltronics SF500

This card only supports polled I/O with the following setup:

- I/O connection #1 input size of 68<sup>1</sup> bytes.
- I/O connection #1 output size of 38 bytes.

Some configurations may also require some of the following information:

- Device Type is 12(0x0c)
- Product code is 12
- Vendor ID is 90 (0x5a)

---

<sup>1</sup> 68 is the correct value for BW500/SF500 units that have firmware V 3.05 or greater and have all the values of P762 turned on. For older units, the input size is 62.

# EDS Files

DeviceNet requires an Electronic Data Sheet (EDS) to configure a slave. An EDS contains product specific information and is designed to make configuration easier.

## **AiRanger / SITRANS LU Series, CraneRanger and InterRanger DPS 300**

- The file for the SmartLinx DeviceNet card is called hms-1002.eds and is located on a disk shipped with the card.

## **EnviroRanger ERS 500, MultiRanger 100/200, HydroRanger 200**

- The file for the SmartLinx DeviceNet card is called hms-1003.eds and is located on a disk shipped with the card.

## **Milltronics BW500, Milltronics SF500,**

- The file for the SmartLinx DeviceNet card is called hms-1003.eds and is located on a disk shipped with the card.

## Sample Code

Also on the disk shipped with the card, are some sample PLC programs for the Allen-Bradley PLC5, SLC500, and ControlLogix. These programs are intended as a “guide only.” Siemens Milltronics assumes no responsibilities for their application.

## Set-up Procedure

The set-up procedure will vary depending on the type of equipment used. Generally do the following steps:

1. Import the Siemens Milltronics EDS file into your network configuration software.
2. In the software, configure the Siemens Milltronics instrument at the desired MAC address.
3. Add the Siemens Milltronics instrument to the ScanList of the scanning instrument (DeviceNet master). It would be added as Polled I/O with the Rx and Tx as stated on page 11 for the product you are using.
4. Download the new configuration into the DeviceNet Scanner.
5. Configure the Siemens Milltronics instrument to the correct baud rate and MAC ID (P751, P752) and connect it to the network. Refer to the following section on Specific Parameters.
6. Program the PLC to read and write the information from the scanner. This step varies with the PLC. For example, for the PLC5, set up a block transfer read and a block transfer write. Please see the support disk for example code.



# Communications Parameters

The following parameters must be defined in the Siemens Milltronics instrument to establish successful communication. Instructions on how to set these parameters are found in the associated instrument manual.

## Note:

- f denotes factory setting.

## P751 Baud Rate

Sets the baud rate according to the following table

0	=	125 Kbps f
1	=	250 Kbps
2	=	500 Kbps

## P752 MAC ID

Sets the MAC ID (slave address). Valid addresses range from 0 to 63. The default value is 63.

## Map Element Selection

### P762 Map Element Selection parameter

*P762 allows you to select what elements to include in the Input and Output Tables. By selecting only the data required, you can reduce the amount of data being transferred over the bus.*

## Notes:

- P762 should only be modified by an advanced user who wants to limit the amount of data being transferred. For details, see *Appendix A – Reducing the amount of data being transferred over the Bus* on page 48.
- Changes do not take effect until after a power cycle.

The charts on page 14 give the default values for this parameter. The values differ depending on the category:

- category 1 includes the *AiRanger / SITRANS LU series, CraneRanger series, and InterRanger DPS 300*
- category 2 includes the *EnviroRanger ERS 500, MultiRanger 100/200, and HydroRanger 200*
- category 3 includes the *Milltronics BW500 and Milltronics SF5*
- If the default values are used then the configuration and Data Map (see page 24) in the main body of this manual remain correct. If any of these values is changed, then the Data Map will be shortened and the configuration will change. For details on using P762, see *Appendix A – Reducing the amount of data being transferred over the Bus* on page 48.

**AiRanger / SITRANS LU series, CraneRanger series, and InterRanger DPS 300**      **EnviroRanger ERS 500, MultiRanger 100/200, and HydroRanger 200**

<b>P762 Index</b>	<b>Name of area</b>	<b>Default value</b>	<b>Range</b>	<b>Name of area</b>	<b>Default value</b>	<b>Range</b>
1	Instrument status	1	0 = No 1=Yes	Instrument status	1	0 = No 1=Yes
2	Reading	10	0= No 1...10 = include that number of items	Reading	10	0= No 1...10 = include that number of items
3	Alarm	0	0= No 1...10 = include that number of items	Alarm	10	0= No 1...10 = include that number of items
4	Point on Priority	1	0 = No 1=Yes	Point on Priority	1	0 = No 1=Yes
5	MPA	1	0 = No 1=Yes	MPA	1	0 = No 1=Yes
6	SPA	1	0 = No 1=Yes	SPA	1	0 = No 1=Yes
7	Operating Mode	1	0 = No 1=Yes	Operating Mode	1	0 = No 1=Yes

**Milltronics BW 500 and Milltronics SF 500**

<b>P762 Index</b>	<b>Name of area</b>	<b>Default value</b>	<b>Range</b>
1	Instrument status	1	0 = No 1=Yes
2	Rate	1	0 = No 1=Yes
3	Load	1	0 = No 1=Yes
4	Speed	1	0 = No 1=Yes
5	Total	1	0 = No 1=Yes
6	Relay Status	1	0 = No 1=Yes
7	DI Status	1	0 = No 1=Yes
8	SPA	1	0 = No 1=Yes
9	Command Control	1	0 = No 1=Yes

Milltronics BW 500 and Milltronics SF 500			
10	MultiSpan	1	0 = No 1=Yes
11	PID	1	0 = No 1=Yes
12	Batch	1	0 = No 1=Yes
13	Batch Prewarn	1	0 = No 1=Yes
14	Word Order	1	0 = No 1=Yes
15	Status 2	1 <sup>1</sup>	0 = No 1=Yes
16	Batch Total	1 <sup>1</sup>	0 = No 1=Yes

<sup>1</sup>. For firmware V 3.05, the default is 0. For all higher versions, the default is 1.

## Module Identification

*Parameters P794 and P795 are used together to identify the module type and protocol used.*

### P794 SmartLinX Module Type

*Identifies the module used.*

Value	Module
0	No module present
1	Anybus DT module
2	Anybus S module

### P795 SmartLinX Protocol

*Identifies the protocol used: the value varies according to the module, and whether it is a type 1 or type 2.*

Siemens Milltronics Instrument	Card	P794 value	P795 value
ER-500 BW500 / SF500 MultiRanger 100 / 200	AB RIO	1	72
	Profibus DP	2	1
	DeviceNet	2	37
AiRanger / SITRANS LU	AB RIO	1	72
	Profibus DP	1	24
	DeviceNet	1	34
	Modbus RTU	1	57
	Modem Card	1	133

# P634: Communication Totalizer Resolution

*Parameter P634 is used to set the number of fixed decimal places for Total 1 and Total 2 for SmartLinx communication.*

**Note:** P634 applies only to Milltronics BW500 and Milltronics SF500.

P634 Index	Description	Value	# of decimal places
Primary Index 1	Total 1 for SmartLinx communication	3 *1	3
		2	2
		1	1
		0	0
Primary Index 2	Total 2 for SmartLinx communication	3 *	3
		2	2
		1	1
		0	0

- The asterisk (\*) denotes factory setting.

# Application Layer

This section describes the meanings of data read from, and written to the Siemens Milltronics instrument memory via the SmartLinx DeviceNet connection. The output words (PLC master Write operation) and input words (PLC master Read operation) are described in three areas within this section of the manual. For the AiRanger / SITRANS LU series of products, refer to *Data Map 1: AiRanger / SITRANS LU series, CraneRanger series, and InterRanger DPS 300* on page 21. For the EnviroRanger series, refer to *Data Map 2: EnviroRanger ERS 500, MultiRanger 100/200, HydroRanger 200* on page 27. For the Milltronics BW500, refer to *Data Map 3: Milltronics BW500 and Milltronics SF500* on page 33.

## Parameter Indexes

Most parameters used on Siemens Milltronics instruments are indexed. Indexing allows a parameter to relate to more than one input or output. For example, many parameters are indexed by measurement point while others are indexed by relay output or discrete input.

The way that indexes are handled in the memory map depends on the data access method used.

## Primary Index

An index that relates to an input or output is called a Primary Index. (On some older Milltronics products the primary index is called a point.)

**Example:**

$$P111[3] = 52$$

means P111 (Relay Control Function) for relay 3 is set to value 52

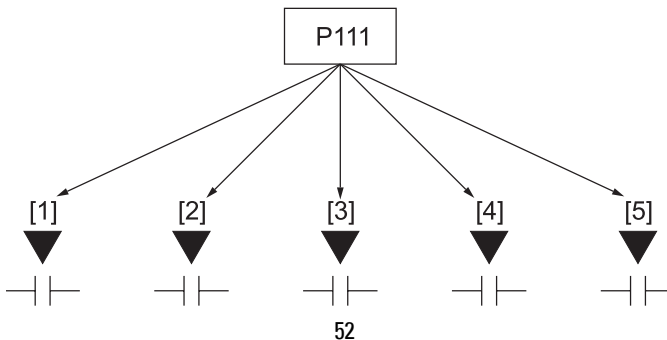

# Secondary Index

Sometimes a parameter requires a second index to allow for multiple values on an indexed input or output. For example a measurement point which calculates a reading on volume can require characterization breakpoints. These breakpoints are given on a secondary index (the primary index relates to the transducer input).

An index that relates to a previously indexed parameter is called a secondary index. (On some older Milltronics products the secondary index is called a mark.)

**Example:**

$$P054[1,3] = 1.6m$$

means P054 (Breakpoint Levels) for breakpoint 3 on transducer 1 is set to 1.6m

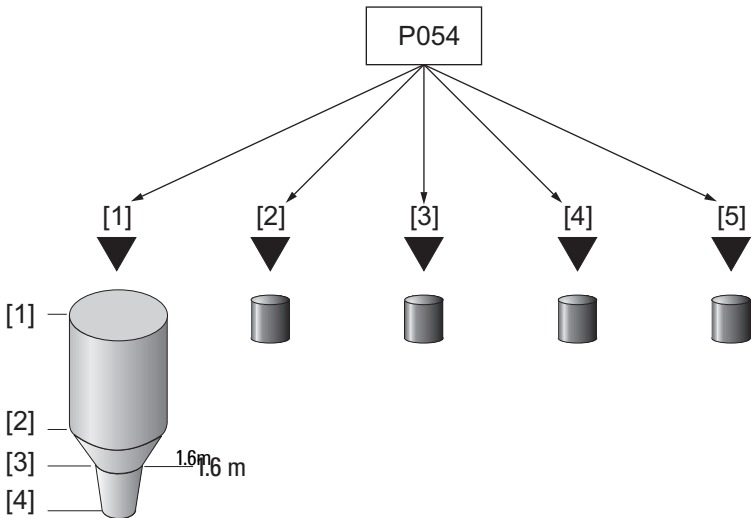

# Data Access Methods

There are three different methods used in the memory mapping to give access to the SmartLinx module parameter table. They are:

- Direct Access
- Multiple Parameter Access (MPA)
- Single Parameter Access (SPA)

## Direct Access

Certain values are mapped directly into words. These words can be monitored continuously but they are not configurable.

## Multiple Parameter Access (MPA)

### Notes:

- MPA is used on Level products only.
- In Siemens Milltronics' products, the memory is arranged as Parameter number, Primary Index, Secondary Index.

This is a hand-shaking method where the user specifies the parameter number, secondary index, decimal place, and format, then the SmartLinx writes into a certain area all 10 primary indexes of that parameter.

## Using Multiple Parameter Access (MPA)

1. In the output table of the PLC (Write Block) write the values for the parameter number, secondary Index, decimal place and format in the correct location.
2. Monitor the Input table of the PLC (Read Block), and watch for the values you wrote to appear in the appropriate locations of the Read block, then go to Step 3.
3. Read the requested values in the appropriate location of the Read Block. These values are continuously updated. Continue reading from these words until values for another parameter are required, then go back to step 1.

**Note:** MPA values are only updated in Run mode (word 12 = 0).

## Parameter Indexing with MPA

### Primary Index

The primary index is implicit in the memory address.

### Secondary Index

The secondary index is nearly always left at zero. See the manual for the Siemens Milltronics SmartLinx instrument for information on parameters, including those which require a secondary index.

# Single Parameter Access (SPA)

**Note:** SPA is used on both Level and Mass Dynamics products.

This is a hand-shaking method where the PLC specifies:

- parameter number
- primary index
- secondary index
- decimal place
- format
- read/write flag
- value

With this method, any value in the Siemens Milltronics product can be read or written.

**Note:** Parameter P999 (Master Reset) is not accessible via the SmartLinX interface on Level products.

## Using Single Parameter Access (SPA)

SPA allows continuous monitoring or demand programming of a parameter.

### Reading a Parameter

1. Set the Read/Write flag in the output table (Write Block) to **0**, "Read"
2. Write the Parameter Number, Primary Index, Secondary Index, Decimal Place and Format in the correct locations.

**Note:** If there is no secondary index, then place a **0** in this location.

3. Monitor the Input table of the PLC (Read Block) and watch for the values you wrote to appear in the appropriate locations, then go to Step 4.
4. Read the requested parameter value in the Input table (Read Block). These values are continuously updated. Continue reading from these words until values for other parameters are required. At that time, go back to step 1.

### Writing a Parameter

1. Set the Read/Write flag in the output table (Write Block) to **0**, "Read"
2. Write the Parameter Number, Primary Index, Secondary Index, Decimal Place and Format in the correct locations.
3. Write the new value of the parameter into the correct location of the output memory (Write Block)
4. Verify the unit is in program mode (not needed for BW500). For Level see bit 10 of status word in Read Block.



5. If the unit is not in program mode, write a 1 to the operating mode word in the output memory (Write Block). Please note that this will only work if the word is already a 0; this only works as a transition.
6. Set the Read / Write flag in the output table (Write Block) to 1 “write.”
7. Monitor the Input table of the PLC (read block) and watch for the values you wrote to appear in the appropriate locations.
8. Set Read / Write flag back to 0.
9. Place unit in Run mode.

**Note:** Parameters for Level Products should only be written to while the unit is in PROGRAM mode. If the level instrument is still in RUN mode, the written value might be ignored.

## Data Map 1: AiRanger / SITRANS LU series, CraneRanger series, and InterRanger DPS 300

### Notes:

- The data maps shown for the Write and Read Blocks apply if P762 is set to the default values (see page 14). If any of these values is changed, the data map will be shortened and the configuration will change. (See *Appendix A – Reducing the amount of data being transferred over the Bus*, on page 48.)
- Refer to the PCL documentation on how to program ‘Reads and Writes’ in your PLC.

This section describes the meaning of the data read from and written to the Siemens Milltronics SmartLinX instrument.

## Write Block

Word	Description	Access	Data Type
0	measurement point on priority	direct	bitmapped
1	parameter number	MPA	integer
2	secondary index (mark)		integer
3	decimal place		integer
4	format		0/1
5	parameter number	SPA	integer
6	primary index (point)		integer
7	secondary index (mark)		integer
8	new value		integer
9	decimal place		integer
10	format		0/1
11	read/write flag		0/1
12	operating mode		direct

## Word 0: Point-on-Priority XPL PLUS

Bits 00-09 set the priority status of corresponding indexed points 1 to 10.

<b>bit</b>	09	08	07	06	05	04	03	02	01	00
<b>index</b>	10	9	8	7	6	5	4	3	2	1

bit status    **0** = normal  
                   **1** = priority

For example, if bits 00 and 02 are set to **1**, then points 3 and 1 are on priority scan. All other bits are reserved and contain 0.

<b>bit</b>	09	08	07	06	05	04	03	02	01	00
<b>index</b>	0	0	0	0	0	0	0	1	0	1

In order to use word 00 to control point-on-priority, you must configure the Siemens Milltronics SmartLinx instrument to permit this. For each point, set Parameter P720 to **1** (manual, BIC-II or SmartLinx SPA) to permit priority control for that point.

**Note:** Point on Priority only applies to the XPL+..

## Word 1: Parameter Number, MPA

Specifies the parameter number for the returned values in words 11 to 20. See *Read Block* on page 24.

## Word 2: Parameter Secondary Index, MPA

Specifies the secondary index for the parameter specified by word 1. This word is ignored for parameters that do not use multiple indexes. See *Parameter Indexes* on page 17 for more information.

## Word 3: Decimal Place, MPA

Specifies the number of decimal places to shift the returned values. This affects words 11 to 20 of the Read Block. Positive values indicate that the decimal place shifts to the left and negative values indicate that the decimal place shifts to the right.

For example:

word 3 = 1: all returned values have the decimal place shifted 1 space to the left and a returned value of 5,213 is interpreted as 521.3.

word 3 = -1: a returned value of 5,213 is interpreted as 52,130.

#### Word 4: Format, MPA

Sets the format for the returned values in word 11 to 20.

0 = normal

1 = percent

**Note:** When the format is selected as “percent,” the decimal place value (word 3 of the Write Block) is ignored and two decimal places are always used. For example, a value of 5947 represents 59.47%.

#### Word 5: Parameter, SPA

Specifies the requested parameter number for Single Parameter Access (SPA). (See page 20.)

#### Word 6: Primary Index, SPA

Specifies the primary index number for the parameter in word 5.

#### Word 7: Secondary Index, SPA

Specifies the secondary index for the parameter in word 5. This word is ignored for parameters that don't use multiple indexes. See *Parameter Indexes* on page 17 for more information.

#### Word 8: Value, SPA

This word contains the value written to the specified parameter and index. The format of this word is specified by words 9 to 10.

To write a value, ensure word 11 = 1 and word 12 = 1. (See also *Data Types* on page 42.)

#### Word 9: Decimal Place, SPA

This word specifies the number of decimal places for the value in word 8 of the Write Block, and also for the parameter value returned in word 28 of the Read Block. Positive values indicate that the decimal place shifts to the left, and negative values indicate that the decimal place shifts to the right.

For example:

word 9 = 1 all returned values have the decimal place shifted 1 space to the left and a returned value of 5,213 is interpreted as 521.3.

word 9 = -1 a returned value of 5,213 is interpreted as 52,130.

#### Word 10: Format, SPA

This word sets the format for the value in word 8 of the Write Block and word 28 of the Read Block.

0 = normal

1 = percent

## Word 11: Read/Write Flag, SPA

This word instructs the read/write application of word 8.

0 = read parameter as described by words 5, 6, 7, 9 and 10; word 8 ignored

1 = set parameter to the value described by words 5 to 10

## Word 12: Operating Mode, SPA

This word sets the operating mode of the Siemens Milltronics SmartLinx instrument.

The operating mode can get out of sync if the remote instrument resets back to run mode locally. This can happen due to a time-out or through local programming. The mode is always reported correctly through the Read block. (See bit 10 of *Word 0: Instrument Status* on page 25.)

To reset the instrument to program mode, write **0** to synchronize the SmartLinx module with the instrument and then write **1** to set the instrument to program mode.

0 = run mode

1 = program mode

## Read Block

Values in words 0 to 10 and word 31 are directly available; no write operation is required to request them.

Values in words 11 to 31 are determined by the write operation that requested them, either MPA or SPA. See *Write Block* on page 21.

Words	Description	Access	Data Type
0	instrument status	Direct	bitmapped
1-10	point reading		integer
11-20	returned values	MPA	integer
21	decimal place		integer
22	format		0/1
23	parameter number		integer
24	parameter secondary index		integer
25	parameter number		integer
26	primary index	SPA	integer
27	secondary index		integer
28	Value Returned		integer
29	decimal place		integer
30	Format		0/1
31	read/write flag		0/1

## Word 0: Instrument Status

Bit	Description										
00 to 09	Measurement Point Status Indicates the operation of measurement points 1 to 10.										
	bit	09	08	07	06	05	04	03	02	01	00
	index	10	9	8	7	6	5	4	3	2	1
	<b>0</b> = operational <b>1</b> = non-operational 'Non-operational' means that either the point is not configured or there is an error in the reading. Point Alarm and Status words are not part of the standard map, but can be added by using P762: see page 48 for details.										
10	Operating Mode <b>0</b> = Siemens Milltronics SmartLinx Instrument in <b>RUN</b> mode <b>1</b> = Siemens Milltronics SmartLinx Instrument in <b>PROGRAM</b> mode										
11-15	Reserved These bits are reserved and set to <b>0</b> .										

## Words 1 to 10: Point Reading

These words contain the value of parameter P920 (Reading) for points 1 to 10, respectively. The reading is expressed as a percent of full scale, multiplied by 100, giving a range of -20,000 to 20,000 which corresponds to -200.00% to 200.00%. Refer to the Siemens Milltronics SmartLinx instrument documentation for a definition of "P920".

### Note:

These values may contain numeric level data for inoperative or malfunctioning points: refer to read word 0 for the actual operational status of the measurement points.

## Words 11 to 20: Returned Values, MPA

These words contain values requested by writing to words 1 to 4 of the Write Block. The type of data and format are specified with that request, and returned in Read words 21 to 24.

## Words 21 and 22; 23 and 24: Decimal Place, Format, Parameter Number and Secondary Index, MPA

These words contain the last values written to Write block words 1 and 4. These words indicate what information is contained in Read block words 11 to 20. These words are provided since there can be a delay between writing a request via a Write, and the appearance of the requested values.

Use these words as an indicator that the requested information is updated.

## Words 25 to 27 and 29 to 31: Parameter Number / Primary Index / Secondary Index and Decimal Place / Format / Read Write Flag, SPA

These words contain the last values written to words 5 to 7 and 9 to 11 of the Write block. They confirm that the parameter value has been written. These words are not updated until the value has been successfully transferred and stored in the Siemens Milltronics SmartLinX instrument.

See Write formats on page 23 for details.

### Word 28: Returned Value, SPA

This word contains the current value of the parameter identified by words 25 to 27 and 29 to 30, regardless of the value of word 11 (Write flag).

If this value does not change when a new value is written to word 8 (Parameter Value) then check the following:

1. Words 5 to 7 and 9 to 10 of the Write block **should match** words 25 to 27 and 29 to 30 of the Read block: if not, then the instrument hasn't responded yet.
2. If words 5 to 7 and 9 to 10 of the Write block **do** match words 25 to 27 and 29 to 30, of the Read block, then the parameter value has not been updated. Check that the Siemens Milltronics SmartLinX instrument is in **PROGRAM** mode and that the program lock (P000) is not on, then try again.

# Data Map 2: EnviroRanger ERS 500, MultiRanger 100/200, HydroRanger 200

**Note:** Refer to the PLC documentation on how to program "reads and writes" in your PLC.

## Write Block

Word	Description	Access	Data Type
0	measurement point on priority	direct	bitmapped
1	parameter number		integer
2	secondary index (mark)	MPA	integer
3	decimal place		integer
4	format		0/1
5	parameter number		integer
6	primary index (point)		integer
7	secondary index (mark)		integer
8	new value	SPA	integer
9	decimal place		integer
10	format		0/1
11	read/write flag		0/1
12	operating mode	direct	0/1

### Word 0: Point-on-Priority

Bits 00-09 set the priority status of corresponding indexed points 1 to 10.

<b>bit</b>	09	08	07	06	05	04	03	02	01	00
<b>index</b>	10	9	8	7	6	5	4	3	2	1

bit status 0 = normal  
1 = priority

For example, if bits 00 and 02 are set to 1, points 3 and 1 are on priority scan. All other bits are reserved and contain 0.

<b>bit</b>	09	08	07	06	05	04	03	02	01	00
<b>index</b>	0	0	0	0	0	0	0	1	0	1

In order to use word 00 to control point-on-priority, you must configure the Siemens Milltronics SmartLinx instrument to permit this. For each point, set Parameter P720 to 1 (manual, BIC-II; or SmartLinx SPA) to permit priority control for that point.

**Note:** Point on Priority only applies to the XPL+.

### Word 1: Parameter Number, MPA

Specifies the parameter number for the returned values in words 21 to 30. See *Read Block* on page 30.

### Word 2: Secondary Index, MPA

Specifies the secondary index for the parameter specified by word 1. This word is ignored for parameters that don't use multiple indexes. See *Parameter Indexes* on page 17 for more information.

### Word 3: Decimal Place, MPA

Specifies the number of decimal places to shift the returned values in words 21 to 30 of the Read Block. Positive values indicate that the decimal place shifts to the left, and negative values indicate that the decimal place shifts to the right.

For example:

- word 3 = 1: all returned values have the decimal place shifted 1 space to the left and a returned value of 5,213 is interpreted as 521.3
- word 3 = -1: a returned value of 5,213 is interpreted as 52,130

### Word 4: Format, MPA

Sets the format for the returned values in words 21 to 30.

0 = normal

1 = percent

**Note:** When the format is selected as "percent" the decimal place value (word 3 of the Write block) is ignored and two decimal places are always used. For example, a value of 5947 represents 59.47%.

### Word 5: Parameter, SPA

Specifies the requested parameter number for Single Parameter Access (SPA). (See page 20.)

### Word 6: Primary Index, SPA

Specifies the primary index number for the parameter in word 5.



## Word 7: Secondary Index, SPA

Specifies the secondary index for the parameter in word 5. This word is ignored for parameters that don't use multiple indexes. See *Parameter Indexes* on page 17 for more information.

## Word 8: Value, SPA

This word contains the value written to the specified parameter and index. The format of this word is specified by words 9 to 10.

To write a value, ensure word 11 = 1 and word 12 = 1. See also *Data Types* on page 42.

## Word 9: Decimal Place, SPA

This word specifies the number of decimal places for the value in word 8 of the Write Block and word 38 of the Read Block. Positive values indicate that the decimal place shifts to the left, and negative values indicate that the decimal place shifts to the right.

For example:

word 9 = 1: all returned values have the decimal place shifted 1 space to the left and a returned value of 5,213 is interpreted as 521.3.

word 9 = -1: a returned value of 5,213 is interpreted as 52,130.

## Word 10: Format, SPA

This word sets the format for the value in word 8 of the Write Block and word 38 of the Read Block.

0 = normal

1 = percent

## Word 11: Read/Write Flag, SPA

This word instructs the read/write application of word 8.

0 = read parameter as described by words 5, 6, 7, 9 and 10; word 8 ignored

1 = set parameter to the value described by words 5 to 10

## Word 12: Operating Mode, SPA

This word sets the operating mode of the Siemens Milltronics SmartLinx instrument.

The operating mode can get out of sync if the remote instrument resets back to run mode locally. This can happen due to a time-out or through local programming. The mode is always reported correctly through the Read block. (See bit 10 of *Word 0: Instrument Status* on page 31.)

To reset the instrument to program mode, write 0 to synchronize the SmartLinx module with the instrument and then write 1 to set the instrument to program mode.

0 = run mode

1 = program mode

# Read Block

Values in words 0 to 20 and 41 are directly available; no write operation is required to request them.

Values in words 21 to 41 are determined by the write operation that requested them, either MPA or SPA. (See *Write Block* on page 27.)

Words	Description	Access	Data Type
0	instrument status		bitmapped
1-10	point reading	direct	integer
11-20	point alarm and status		bitmapped
21-30	returned values		integer
31	decimal place		integer
32	format	MPA	0/1
33	parameter number		integer
34	parameter secondary index		integer
35	parameter		integer
36	parameter primary index		integer
37	parameter secondary index		integer
38	value	SPA	integer
39	decimal place		integer
40	format		0/1
41	read/write flag		0/1

## Word 0: Instrument Status

Bit	Description										
00 to 09	Measurement Point Status Indicates the operation of measurement points 1 to 10										
	bit	09	08	07	06	05	04	03	02	01	00
	index	10	9	8	7	6	5	4	3	2	1
	0 = operational 1 = non-operational 'Non-operational' means that either the point is not configured or there is an error in the reading. Further information is available in the Point Alarm and Status words (words 11 to 20).										
10	Operating Mode <b>0</b> = Siemens Milltronics SmartLinx instrument in <b>RUN</b> mode <b>1</b> = Siemens Milltronics SmartLinx instrument in <b>PROGRAM</b> mode										
11 to 15	Reserved (These bits are reserved and set to <b>0</b> .)										

## Words 1 to 10: Point Reading

These words contain the value of parameter P920 (Reading) for points 1 to 10, respectively. The reading is expressed as a percent of full scale, multiplied by 100, giving a range of -20,000 to 20,000 which corresponds to -200.00% to 200.00%. Refer to the Siemens Milltronics SmartLinx instrument documentation for a definition of "P920."

**Note:** These values may contain numeric level data for inoperative or malfunctioning points: refer to read word 0, and read words 11 to 20 for the actual operational status of the measurement points.

## Words 11 to 20: Point Alarm and Status

These words contain the corresponding alarm and status bits for indexed measurement points 1 to 10, respectively.

### Bit status:

**0** = false

**1** = true

Bit	Description
00	point not in service
01	point failsafe timer expired
02	point failed (cable shorted, open, or transceiver problem)
03	point temperature sensor failed
04 to 12	reserved for future use
13	level emptying
14	level filling
15	scan mode priority

If the product is an AiRanger / SITRANS LU Version 5.23 or above, and P762 is used to turn on the Point Alarm and status bits, then the additional bits are defined:

Bit	Description
04	Low-Low Alarm (1=ON)
05	Low Alarm (1=ON)
06	High Alarm (1=ON)
07	High-High Alarm (1=ON)

### Words 21 to 30: Returned Values, MPA

These words contain values requested by writing to words 1 to 4 of the Write Block. The type of data and format are specified with that request, and returned in Read words 31 to 34.

### Words 31 and 32; 33 and 34: Decimal Place, Format, Parameter Number and Secondary Index, MPA

These words contain the last values written to Write block words 1 and 4. These words indicate what information is contained in Read block words 21 to 30. These words are provided since there can be a delay between writing a request via a Write, and the appearance of the requested values.

Use these words as an indicator that the requested information is updated.

### Words 35 to 37 and 39 to 41: Parameter Number / Primary Index / Secondary Index and Decimal Place / Format / Read Write Flag, SPA

These words contain the last values written to words 5 to 7 and 9 to 11 of the Write block. They confirm that the parameter value has been written. These words are not updated until the value has been successfully transferred and stored in the Siemens Milltronics SmartLinx instrument.

See Write formats on page 28 for details.

### Word 38: Returned Value, SPA

This word contains the current value of the parameter identified by words 35 to 37 and 39 to 40, regardless of the value of word 11 (Write flag).

If this value does not change when a new value is written to word 8 (Parameter Value) then check the following:

1. Words 5 to 7 and 9 to 10 of the Write block **should match** words 35 to 37 and 39 to 40 of the Read block: if not, then the instrument hasn't responded yet.
2. If words 5 to 7 and 9 to 10 of the Write block **do** match words 35 to 37 and 39 to 40, of the Read block, then the parameter value has not been updated. Check that the Siemens Milltronics SmartLinx instrument is in **PROGRAM** mode and that the program lock (P000) is not on, then try again.

# Data Map 3: Milltronics BW500 and Milltronics SF500

**Note:** The data maps shown for the Write and Read Blocks apply if P762 is set to the default values (see page 14). If any of these values is changed, the data map will be shortened and the configuration will change. (See *Appendix A – Reducing the amount of data being transferred over the Bus*, on page 48.)

## Write Block

The words in the write operation allow access to the Siemens Milltronics SmartLinx instruments as Single Parameter Access (SPA) only.

Description	Start	End	Size	Data Type
parameter number, SPA	0	0	1	integer
primary index, SPA	1	1	1	integer
secondary index, SPA	2	2	1	integer
new value, SPA	3	4	2	UINT32
decimal place, SPA	5	5	1	integer
format, SPA	6	6	1	integer
read/write flag, SPA	7	7	1	integer
command control	8	8	1	bitmapped
multispan selection	9	9	1	1-4
PID 1 setpoint value	10	11	2	UINT32
PID 2 setpoint value	12	13	2	UINT32
batch setpoint value	14	15	2	UINT32
batch prewarn setpoint value	16	17	2	UINT32
word order	18	18	1	0/1

### Notes:

- All the 32 bit numbers (except for the SPA numbers) have a fixed decimal place of 3 digits. For example PID 1 setpoint value of 3,245 is a value of 3.245 in the BW500.
- To make a change to any parameter in the BW500 using SmartLinx, P799 Communications Control must be set to 1.

**Word 0: Parameter, SPA**

Specifies the parameter number.

**Word 1: Primary Index, SPA**

Specifies the primary index number for the parameter specified by word 0.

**Word 2: Secondary Index, SPA**

Specifies the secondary index for the parameter specified by word 0. This word is ignored for parameters that don't use multiple indexes.

**Words 3, 4: New Value, SPA**

The new value of the specified parameter and index.

**Word 5: Decimal Place, SPA**

This word specifies the number of decimal places for the value in words 3 and 4. Positive values indicate that the decimal place shifts to the left, and negative values indicate that the decimal place shifts to the right.

If word 5 = 1: all returned values have the decimal place shifted 1 space to the left and a returned value of 5,213 is interpreted as 521.3.

If word 5 = -1: a returned value of 5,213 is interpreted as 52,130.

**Word 6: Format, SPA**

This word is always 0.

**Word 7: Read / Write Flag, SPA**

This word determines whether the instrument will allow parameter values to be written.

**0** = read

**1** = write

## Word 8: Command Control, Operational Commands

The command control word is used to control the unit. Each bit gives access to a command or state as if the operator was using the keypad.

Bits initiating a command (7 to 12) must change state in order to cause the command to begin. For example, to reset totalizer 1, Bit 9 must be set to 0, then changed to 1. It can stay set or clear for any period.

Bit #	Description	Bit Clear (0)	Bit Set (1)
00	PID 1 mode	manual	auto
01	PID 1 freeze	no	yes
02	PID 1 setpoint source	local	remote
03	PID 2 mode	manual	auto
04	PID 2 freeze	no	yes
05	PID 2 setpoint source	local	remote
06	zero	no change	start
07	span	no change	start
08	reset totalizer 1	no change	reset
09	reset totalizer 2	no change	reset
10	reset batch totalizer	no change	reset
11	print		print
12	reserved		
13	reserved		
14	reserved		
15	reserved		

### Bit 00 and 03: PID Mode

Sets the mode of PID control to either manual (output determined by P410 – PID Manual) or auto (output determined by PID control in instrument).

### Bit 02 and 05 Setpoint Source

Controls the location of the setpoint. If it is set as “local,” then the setpoint used is internal to the BW500. If the setpoint source is set to “remote,” then the setpoint is controlled by a mA input.

For setpoint control through communications this must be set to “local.”

### Bit 01 and 04: Freeze

Suspends PID function when PID Mode = 1 (“auto”) and holds the output at the last value. PID functionality resumes when the freeze bit is cleared.

### Bit 06: Zero

Sets the zero point for calibration of the belt scale.

This is a momentary setting that must be reset to “0” once the input is accepted. To check that the input was accepted read word 0, bit 7 (zero status) and ensure it shows a “1.” Once it shows a “1” then reset this bit to “0.”

**Bit 07: Span**

Sets the span for calibration of the belt scale.

This is a momentary setting that must be reset to “0” once the input is accepted. To check that the input was accepted read word 0, bit 8 (Span Status) and ensure it shows a “1.” Once it shows a “1” then reset this bit to “0.”

**Bit 08: Reset Totalizer 1**

Causes the internal totalizer 1 to be reset to 0.

This is a momentary setting that must be reset to “0” once the input is accepted. To reset this back to 0, the use of a timer is recommended.

**Bit 09: Reset Totalizer 2**

Causes the internal totalizer 2 to be reset to 0.

This is a momentary setting that must be reset to “0” once the input is accepted. To reset this back to 0, the use of a timer is recommended.

**Bit 10: Reset Batch Totalizer**

Causes the batch totalizer to be reset to 0.

This is a momentary setting that must be reset to “0” once the input is accepted. To reset this back to 0, the use of a timer is recommended.

**Bit 11: Print**

Starts print operation. One of the communications ports on the BW500 must be configured for a printer.

This is a momentary setting that must be reset to “0” once the input is accepted. To reset this back to 0, the use of a timer is recommended.

**Word 9: Multispan Selection**

Sets the current span (1 to 4). Any parameters that relate to span will use this value to determine which span is referenced. See the manual for the BW500 for more information on multispan.

**Words 10 to 13: PID Setpoints**

Contain the current setpoint values as P415 in the Milltronics BW500.

To write these setpoints bits 02 and 05 in word 8 - Control must be set to “local.”

**Words 14 and 15: Batch Setpoint**

Contain the current setpoint value as P564 in the Milltronics BW500.

**Words 16 and 17: Batch Prewarn Setpoint**

Contain the current setpoint value as P567 in the Milltronics BW500.



## Word 18: Word Order

This word controls which word comes first in the UINT32 integers. For a value 0, the most significant word is given first. For a value 1, the least significant word is given first.

0	MSW first
1	LSW first

## Read Block

Values returned in the words in the read are in response to the write to the Siemens Milltronics SmartLinX instrument.

Words 0 through 20 have values with fixed meanings and formats. This means that you do not have to start communications with a write in order to use read, the data is always there.

Words 22 through 30 are values returned in response to writing words 2 through 7 for Single Parameter Access (SPA).

Description	Start	End	Size	Type
instrument status 1	0	0	1	bitmapped
rate	1	2	2	UINT32
load	3	4	2	UINT32
speed	5	6	2	UINT32
total 1	7	8	2	UINT32
total 2	9	10	2	UINT32
relay status	11	11	1	bitmapped
discrete input status	12	12	1	bitmapped
multispan selection	13	13	1	integer
PID 1 setpoint value	14	15	2	UINT32
PID 2 setpoint value	16	17	2	UINT32
batch setpoint value	18	19	2	UINT32
batch prewarn setpoint value	20	21	2	UINT32
parameter, SPA	22	22	1	integer
primary index, SPA	23	23	1	integer
secondary index, SPA	24	24	1	integer
new value, SPA	25	26	2	UINT32
decimal place, SPA	27	27	1	integer
format, SPA	28	28	1	integer
read / write flag, SPA	29	29	1	1/0
word order	30	30	1	1/0
Instrument Status 2 <sup>1</sup>	31	31	1	bitmapped
Batch Total <sup>1</sup>	32	33	2	UNIT32

1. This is only available in firmware V 3.05 or higher. In V 3.05, these locations are "turned off" in P762. In higher firmware, they are defaulted on.

## Word 0: Instrument Status 1

This word is used to feed back the current operating state of the product. Each bit gives the state of different parts of the product, some mutually exclusive, others are not. The state should be checked to verify operation.

Bit #	Description	Bit Clear (0)	Bit Set (1)
0	PID 1 mode	manual	auto
1	PID 1 freeze	no	yes
2	PID 1 setpoint source	local	remote
3	PID 2 mode	manual	auto
4	PID 2 freeze	no	yes
5	PID 2 setpoint source	local	remote
6	zero	no	in progress
7	span	no	in progress
8	reset totalizer 1	no change	reset
9	reset totalizer 2	no change	reset
10	reset batch totalizer	no change	reset
11	printing	not printing	printing
12	write privileges	no	yes
13	system configured	not configured	run mode
14	mode	calibration mode	run mode
15	totalizing	not totalizing	totalizing

### Bits 0 to 5: PID Status

These bits give the status of the product. For example Bit 0 is the mode of the PID 1 controller (if used). It indicates whether the PID is in manual or auto modes.

### Bit 6: Zero Status

Indicates whether the unit is currently performing a Zero calibration.

### Bit 7: Span Status

Indicates whether the unit is currently performing a Span calibration.

### Bits 8 to 11: Totalizer Status

Indicate "1" if the reset totalizer or print operations are taking place (these are momentary and will only stay set for a very short period).

**Bit 12: Write Privileges**

Indicates whether the PLC can write parameters/commands to the product. This is controlled by parameter P799.

P799 = 1      PLC may change the Siemens Milltronics SmartLinX instrument's parameters  
 P799 = 0      PLC can only read.

**Bit 13: Configuration Status**

Indicates whether the unit is configured (all required parameters entered).

**Bit 14: Program Mode**

Indicates program (calibration) mode:

0 = PROGRAM mode

1 = RUN mode

**Bit 15: Totalizing Status**

Indicates whether the unit is totalizing.

**Words 1, 2: Rate**

Contains the current rate reading in engineering units. (See the Milltronics BW500 manual for a full description of this reading.)

**Words 3, 4: Load**

Contains the current load reading in engineering units. (See the Milltronics BW500 manual for a full description of this reading.)

**Words 5, 6: Speed**

Contains the current speed reading in engineering units. (See the Milltronics BW500 manual for a full description of this reading.)

**Words 7, 8: Total 1<sup>1</sup>**

Contains the current value for totalizer 1 in engineering units. (See the Milltronics BW500 manual for a full description of this reading.)

**Words 9, 10: Total 2<sup>1</sup>**

Contains the current value for totalizer 2 in engineering units. (See the Milltronics BW500 manual for a full description of this reading.)

---

<sup>1</sup> The number of fixed decimal places for this value is controlled by P634 primary indexes 1 and 2. The default setting is 3. (See page 16 for details.)

## Word 11: Relay Status

Shows the current logical status of all relays.

<b>bit</b>	04	03	02	01	00
<b>relay</b>	05	04	03	02	01

0 = relay not asserted

1 = relay asserted

“Asserted” indicates that the function controlling the relay is in an active state. Relay contacts can open or close based on this state, see your instrument manual for details.

## Word 12: Discrete Input Status

Shows the current logical status of all discrete inputs.

<b>bit</b>	04	03	02	01	00
<b>Input</b>	05	04	03	02	01

0 = discrete input open

1 = discrete input closed

## Word 13: Multispan Selection

Shows the currently selected span (1 to 4).

## Words 14, 15: PID 1 Setpoint Value

Contains the current setpoint value for PID 1 in engineering units. (See the Milltronics BW500 manual for a full description of this reading.)

## Words 16, 17: PID 2 Setpoint Value

Contains the current setpoint value for PID 2 in engineering units. (See the Milltronics BW500 manual for a full description of this reading.)

## Words 18, 19: Batch Setpoint Value

Contains the value of P564 – Batch Setpoint. (See the Milltronics BW500 manual for a full description of this parameter.)

## Words 20, 21: Batch Pre-Warn Setpoint Value

Contains the value of P567 – Batch Pre-Warn Setpoint. (See the Milltronics BW500 manual for a full description of this parameter.)

## Words 22 to 24: Parameter Number / Primary Index / Secondary Index, SPA; words 27 to 29: Decimal Place, Format, Read/Write flag

These words contain the last values written to words 0 to 2 and words 5 to 7 of the Write area. They confirm that the parameter value has been written. These words are not updated until the value has been successfully transferred and stored in the Siemens Milltronics SmartLinX instrument.

Use these words as an indicator that the requested information has been updated.

### Words 25, 26: Value, SPA

The value of the specified parameter and index.

### Word 30: Word Order

The placement of the most significant word (MSW).

0 = MSW first

1 = MSW second

### Word 31 Instrument Status 2

This word is used to feed back the current operating state of the product. Each bit gives the state of different parts of the product, some mutually exclusive, others are not. The state should be checked to verify operation.

Bit #	Description	Bit Clear (0)	Bit Set (1)
0	Totalizer 1 overflow	no overflow	overflow condition
1	Totalizer 2 overflow	no overflow	overflow condition

#### Bits 0 Totalizer 1 overflow

If Totalizer 1 has overflowed, (that is, has exceeded the spaces available in SmartLinX), this bit is set. The overflow condition can be changed by reducing Communication Totalizer resolution (P634).

#### Bit 1 Totalizer 2 overflow

If Totalizer 2 has overflowed, (that is, has exceeded the spaces available in SmartLinX), this bit is set. The overflow condition can be changed by reducing Communication Totalizer resolution (P634).

### Word 32 Batch Totalizer

Contains the current value for the Batch Totalizer in engineering units. (See the Milltronics BW500 manual for a full description of this reading).

# Data Types

The Siemens Milltronics SmartLinx instrument parameters take on many values in various formats, as discussed in the Siemens Milltronics SmartLinx instrument manual. For the convenience of the programmer, those values are converted to and from 16-bit integer numbers, since those are easily handled by most PLCs.

## Integer

### Level Products

Integer parameter values are by far the most common. For example, parameter P920 (Reading) returns a number representing the current reading (either level or volume, depending on the Siemens Milltronics SmartLinx instrument configuration).

Numeric values may be requested or set in units or percent of span, and may be specified with a number of decimal places.

Numeric values must be in the range -20,000 to be +20,000 to be valid. If a parameter is requested and its value is more than +20,000, the number 32,767 is returned; if it is less than -20,000, the number -32,768 is returned. If this happens, increase the number of decimal places for that parameter.

If a parameter cannot be expressed in terms of percent (e.g. span), or has no meaningful value, the special number 22,222 is returned. Try requesting the parameter in units, or refer to the Siemens Milltronics SmartLinx instrument manual to understand the format and use of the requested parameter.

### Mass Dynamics Products

Integers used on the Mass Dynamics products can have any valid value. So, the entire range from -32,768 to 32,767 or 0 to 65,535 is available and no values are used as error conditions.

## Bit Values

Bits are packed into registers in groups of 16 bits (1 word). In this manual bits are numbered from 00 to 15, with bit 00 referring to the least significant bit and bit 15 referring to the most significant bit.

15	14	13	12	11	10	09	08	07	06	05	04	03	02	01	00
MSB															LSB

## Unsigned Double Precision Integer (UINT32)

**Note:** Used for Mass Dynamics products only.

Large numbers are put into unsigned 32-bit integers. By default they are set up so that the first word (register) is the most significant word (MSW) and the second word (register) is the least significant word (LSW) depending on the setting of the word order bit.

For example, when reading words 7 and 8 on the Mass Dynamics block (Total 1), the 32 bits would look like the following:

word 7			word 8		
15	MSB	0	15	LSB	0
31	32-bit integer value (UINT32)				0

The whole is read as a 32-bit integer.

## Split Values

**Note:** Used for Level products only

Certain parameters are actually a pair of numbers separated by a colon, in the format xx:yy.

**One example is P807, Transducer Noise, where:**

xx = the average noise value in dB.

yy = the peak noise in dB.

The number which corresponds to xx:yy, either for reading or setting a parameter, is determined by the following formula:

**For storing to the Siemens Milltronics device:**

value =  $(xx + 128) \times 256 + (yy + 128)$

**For reading from the Siemens Milltronics device:**

xx =  $(\text{value} / 256) - 128$

yy =  $(\text{value} \% 256) - 128$

**To compute the modulus where % is the modulus operator:**

value<sub>1</sub> = value / 256

value<sub>2</sub> = remainder of value<sub>1</sub>

value<sub>3</sub> = value<sub>2</sub> x 256

yy = value<sub>3</sub> - 128

It may simplify programming to notice:

xx = (most significant byte of value) - 128

yy = (least significant byte of value) - 128

# Text Messages

**Note:** Used for Level products only

If a Siemens Milltronics device parameter returns a text message, that message is converted to an integer and provided in the register. The numbers are shown in the table below::

Number	Text Message as displayed on LCD
22222	invalid value
30000	off
30001	on
30002	≡≡≡≡
30003	⊠⊠⊠⊠ (parameter does not exist)
30004	err
30005	err1
30006	open
30007	shrt
30008	pass
30009	fail
30010	hold
30011	lo
30012	hi
30013	de
30014	en
30015	- - - - (parameter has not been set)
-32768	value is less than -20,000
32767	value is greater than 20,000



## Relay Function Codes (P111 in Level Products Only)

If a Siemens Milltronics instrument parameter returns a relay function code, that message is converted to a number and provided in the register. The numbers are shown in the table below (see the Siemens Milltronics SmartLinx instrument manual for full information on P111):

Relay Function Code	Number	P111
off, relay not used	0	0
undesignated level alarm	1	1
low-low level alarm	2	1 – LL
low level alarm	3	1 – L
high level alarm	4	1 – H
high-high level alarm	5	1 – HH
in bounds alarm	6	2
in bounds alarm	7	2 – B1
in bounds alarm	8	2 – B2
out of bounds alarm	9	3
out of bounds alarm	10	3 – B1
out of bounds alarm	11	3 – B2
rate of level change alarm	12	4
rate of level change alarm	13	4 – R1
rate of level change alarm	14	4 – R2
temperature alarm	15	5
loss of echo (LOE) alarm	20	6
transducer cable fault alarm	16	7
pump efficiency alarm	17	8
clock failure alarm	18	9
time of day alarm	19	10
pump failure alarm	21	11
totalizer	22	40
flow sampler	23	41
fixed duty assist	25	50
fixed duty backup	26	51
alternate duty assist	30	52
alternate duty backup	31	53
service ratio duty assist	35	54
service ratio duty backup	36	55
first in first out (FIFO)	40	56
time	45	60
overflow	50	61

Relay Function Code	Number	P111
aeration	55	62
gate	60	63
flush valve	65	64
communication	66	65
pump failure alarm	70	11
power failure alarm	71	12
unknown function	200	

# Troubleshooting

---

## Generally

In all cases, first check that the SmartLinX module has passed its on-going built-in self test (Siemens Milltronics SmartLinX instrument parameter P790). The result should be "pass."

If "fail" is indicated, either the module is defective, or the module connector on the Siemens Milltronics SmartLinX instrument is defective.

If "err1" is indicated, the Siemens Milltronics software doesn't recognize the installed module. Please contact Siemens Milltronics or your distributor for instructions and/or upgraded Siemens Milltronics SmartLinX instrument software.

Make sure the Siemens Milltronics instrument is set to a unique address, and does not conflict with any other slave(s) on the bus.

Check the configuration of the scanning master, and make sure it is functioning properly.

If an AiRanger / SITRANS LU is being used, check P795 to make sure that it is equal to 24 (DeviceNet module). If this parameter is showing any other number then you have the wrong SmartLinX card.

## Specifically

1. The card passes the built in self test, but will not connect to the network.
  - Check to make sure P751, P752 are set correctly and that you do not have another instrument on the LAN with the same MAC ID.
  - Check to make sure all 8 DIP switches are set correctly.
  - Check the wiring to the card (or terminal strips)
  - Verify that the Read and Write Block sizes are correct. This is particularly important if you are using P762.
2. The lights on the card indicate that it is OK and communicating, but I cannot see any data in the PLC.
  - When you configured your master, did you map the data into the M files (AB only) and did you add code to the PLC you access then.
  - Some Device net scanners have a control word where you can place the scanner in Ideal Mode. Check that your scanner is in Run mode.

## Technical Support or Product Feedback

For product feedback or technical support, please contact your local Siemens Milltronics representative or e-mail us at [SmartLinX@siemens-milltronics.com](mailto:SmartLinX@siemens-milltronics.com).

# Appendix A – Reducing the amount of data being transferred over the Bus

You can limit the amount of data being transferred over the Bus, and save both bandwidth and memory, by using P762. However, when you reduce the size of the data map, the configuration will change. If the data block sizes in the device do not match what is configured in the master, no communications will occur. Therefore it is critical to calculate the size of the new map. The calculation is different for level applications and for mass dynamics applications.

The following sections provide explanations and examples of the calculation required, together with a worksheet to use as a template. The first section explains how it works with level products, and the second explains how it works with mass dynamics products. In each section, the Write Block map is calculated first, followed by the Read Block.

## Level Products

The Smartlinx map<sup>1</sup> is controlled by the values of the indices of P762. By turning on an index (setting the value to one or more), you activate both the read and write blocks associated with that index. The table below shows which values in the read/write blocks are turned on by each P762 index.

Name of area	P762 Point	Value	Read area turned On	Write area turned on
Status	1	1	Instrument status	-----
Reading	2	1 -10	1-10 point readings	-----
Alarm	3	1-10	1-10 point alarm and status	-----
Point on Priority	4	1	-----	Measurement point on Priority
MPA	5	1	Returned Values (1-10)	Parameter number
			Decimal place	Secondary index
			Format	Decimal place
			Parameter number	Format
			Secondary index	-----
SPA	6	1	Parameter Number	Parameter Number
			Primary index	Primary index
			Secondary index	Secondary index
			Returned Value	New Value
			Decimal Place	Decimal Place
			Format	Format
			Read/Write	Read/ Write
Operating Mode	7	1	-----	Operating Mode

<sup>1</sup> For examples of the data maps before modification, see pages 50 and 52.

# Write Block

The standard Write block is made up of the following sections: point on priority, MPA, SPA, and operating mode. If any of these sections is 'turned off' by setting the corresponding part of P762 to a zero, the new map will shift down accordingly and the size will be reduced by that amount. Multiply the parameter value by the memory size, then add up the results to get the total.

**Write Block Template for Level Products**

Name of area	P762 Point	value	Memory size for Write block per value	Result of multiplying value * memory size
Status	1		0	
Reading	2		0	
Alarm	3		0	
Point on Priority	4		1	
MPA	5		4	
SPA	6		7	
Operating mode	7		1	
			<b>Total words:</b>	

### Example 1:

If you want only Point status, and to read the first 7 point readings, the chart is:

Name of area	P762 Point	value	Memory size for Write block per value	value * memory size
Status	1	1	0	0
Reading	2	7	0	0
Alarm	3	0	0	0
Point on Priority	4	0	1	0
MPA	5	0	4	0
SPA	6	0	7	0
Operating mode	7	0	1	0
			<b>Total words:</b>	<b>0</b>

The output data block (Write block) is now 0 words in size (0 bytes).

No map

### Example 2:

If you want only SPA, then the chart is:

Name of area	P762 Point	value	Memory size for Write block per value	value * memory size
Status	1	0	0	0
Reading	2	0	0	0
Alarm	3	0	0	0
Point on Priority	4	0	1	0
MPA	5	0	4	0
SPA	6	1	7	7
Operating mode	7	0	1	0
			<b>Total words:</b>	<b>7</b>

The output data block (Write block) is now 7 words in size (14 bytes) and the Word numbers have shifted to a lower value

### New Write Block Data Map

Word	Description
0	Parameter number
1	Parameter primary index
2	Parameter secondary index
3	Parameter value
4	Decimal place
5	Format
6	Read / Write flag

### Original Write Block Data Map for Level Products

Words	Description	Access	Data Type
0	measurement point on priority	direct	bitmapped
1	parameter number	MPA	integer
2	parameter secondary index <sup>1</sup>		integer
3	decimal place		integer
4	format		0/1

Words	Description	Access	Data Type
5	parameter number		integer
6	parameter primary index		integer
7	parameter secondary index		integer
8	parameter value	SPA	integer
9	decimal place		integer
10	format		0/1
11	read/write flag		0/1
12	operating mode	direct	0/1

1. The primary index is implicit in the address of the returned parameter values.

## Read Block

The standard Read block is made up of the following sections: status, reading, alarm, MPA, and SPA. If any of these sections is 'turned off' by setting the corresponding part of P762 to a zero, the new map will shift down accordingly and the size will be reduced by that amount for the Read block. Multiply the parameter value by the memory size, then add up the results to get the total.

**Note:** For the AiRanger / SITRANS LU series, CraneRanger, and InterRanger DPS 300, the Read Block size cannot exceed 64 bytes.

### Read Block Template for Level Products

Name of area	P762 Point	value	Memory size for Read block per value	Result of multiplying value * memory size
Status	1		1	
Reading	2		1	
Alarm	3		1	
Point on Priority	4		0	
MPA	5		14	
SPA	6		7	
Operating mode	7		0	
			<b>Total Words:</b>	

### Example 1:

If you want only Instrument status, and to read the first 7 point readings, then the chart is:

Name of area	P762 Point	value	Memory size for Read block per value	value * memory size
Status	1	1	1	1
Reading	2	7	1	7
Alarm	3	0	1	0
Point on Priority	4	0	0	0
MPA	5	0	14	0
SPA	6	0	7	0
Operating mode	7	0	0	0
			<b>Total words:</b>	<b>8</b>

The input data block (Read block) is now 8 words in size (16 bytes), and the Word numbers have shifted to a lower value.

#### New Read Block Data map:

Word	Description
0	Instrument status
1	Reading for point 1
2	Reading for point 2
3	Reading for point 3
4	Reading for point 4
5	Reading for point 5
6	Reading for point 6
7	Reading for point 7

### Example 2:

If you want only SPA, then the chart is:

Name of area	P762 Point	value	Memory size for Read block per value	value * memory size
Status	1	0	1	0
Reading	2	0	1	0
Alarm	3	0	1	0
Point on Priority	4	0	0	0
MPA	5	0	14	0
SPA	6	1	7	7
Operating mode	7	0	0	0
			<b>Total words:</b>	<b>7</b>

The input data block (Read block) is now 7 words in size (14 bytes), and the Word numbers have shifted to a lower value.

#### New Read Block Data map:

Word	Description
0	Parameter number
1	Parameter primary index
2	Parameter secondary index
3	Parameter returned value
4	Decimal place
5	Format
6	Read/Write flag

#### Original Read Block Data map for Level Products

Words	Description	Access	Data Type
0	instrument status		bitmapped
1-10	point reading	direct	integer
11-20	point alarm and status		bitmapped
21-30	returned values		integer
31	decimal place		integer
32	format	MPA	0/1
33	parameter number		integer
34	parameter secondary index		integer



Words	Description	Access	Data Type
35	parameter	SPA	integer
36	parameter primary index		integer
37	parameter secondary index		integer
38	value		integer
39	decimal place		integer
40	format		0/1
41	read/write flag		0/1

## Mass Dynamics Products

The Smartlinx map<sup>1</sup> is controlled by the values of the indices of P762. By turning on an index (setting the value to one or more), you activate both the read and write blocks associated with that index. The table below shows which values in the read/write blocks are turned on by each P762 index.

Name of area	P762 Point	Value	Read area turned On	Write area turned on
Status	1	1	Instrument status	-----
Rate	2	1	Rate	-----
Load	3	1	Load	-----
Speed	4	1	Speed	-----
Total	5	1	Total 1	-----
			Total 2	
Relay Status	6	1	Relay Status	-----
DI Status	7	1	Discrete Input Status	-----
SPA	8	1	Parameter Number	Parameter Number
			Primary index	Primary index
			Secondary index	Secondary index
			Returned Value	New Value
			Decimal Place	Decimal Place
			Format	Format
			Read/Write	Read/ Write
Command Control	9	1	-----	Command Control
Multispan	10	1	-----	Multispan Selection
PID	11	1	-----	PID 1 setpoint value
				PID 2 setpoint value
Batch	12	1	-----	Batch Setpoint Value

<sup>1</sup> For examples of the data maps before modification, see pages 55 and 57

<b>Batch Prewarn</b>	13	1	-----	Batch Prewarn Setpoint Value
<b>Word Order</b>	14	1	Word order	Word order
<b>Status 2</b>	15	1	Instrument Status 2	-----
<b>Batch Total</b>	16	1	Batch Total	-----

## Write Block

The standard Write block is made up of the following sections: SPA, command control, multispan, PID, batch, batch prewarn, word order. If any of these sections is 'turned off' by setting the corresponding part of P762 to a zero, the new map will shift down accordingly and the size will be reduced by that amount. Multiply the parameter value by the memory size, then add up the results to get the total

### Write Block Template for Mass Dynamic Products

Name of area	P762 Point	value	Memory size for Write block per value	Result of multiplying value * memory size
Status	1		0	
Rate	2		0	
Load	3		0	
Speed	4		0	
Total	5		0	
Relay Status	6		0	
DI Status	7		0	
SPA	8		8	
Command Control	9		1	
Multispan	10		1	
PID	11		4	
Batch	12		2	
Batch Prewarn	13		2	
Word Order	14		1	
Satus 2	15		0	
Batch Total	16		0	
			<b>Total words:</b>	

## Example 1:

If you want only rate, load, and batch prewarn, then the chart is:

Name of area	P762 Point	value	Memory size for Write block per value	value * memory size
Status	1	0	0	0
Rate	2	1	0	0
Load	3	1	0	0
Speed	4	0	0	0
Total	5	0	0	0
Relay Status	6	0	0	0
DI Status	7	0	0	0
SPA	8	0	8	0
Command Control	9	0	1	0
Multispan	10	0	1	0
PID	11	0	4	0
Batch	12	0	2	0
Batch Prewarn	13	1	2	2
Word Order	14	0	1	0
Status 2	15	0	0	0
Batch Total	16	0	0	0
			<b>Total words:</b>	2

The input data block (Write block) is now 2 words in size (4 bytes) and the Word numbers have shifted to a lower value:

### New Write Block Data Map:

Word	Description
0-1	Batch prewarn

### Original Write Block Data Map for Mass Dynamic Products

Description	Start	End	Size	Data Type
parameter number, SPA	0	0	1	integer
primary index, SPA	1	1	1	integer
secondary index, SPA	2	2	1	integer
value, SPA	3	4	2	UINT32
decimal place, SPA	5	5	1	integer
format, SPA	6	6	1	integer
read / write flag, SPA	7	7	1	integer
command control	8	8	1	bitmapped
multispan selection	9	9	1	1-4
PID 1 setpoint value	10	11	2	UINT32
PID 2 setpoint value	12	13	2	UINT32
batch setpoint value	14	15	2	UINT32
batch prewarn setpoint value	16	17	2	UINT32
word order	18	18	1	0/1

# Read Block

The standard Read block is made up of the following sections: status, rate, load, speed, total, relay status, DI status, multispan, PID, batch, batch prewarn, SPA, Word order. If any of these sections is 'turned off' by setting the corresponding part of P762 to a zero, the new map will shift down accordingly and the size will be reduced by that amount, for the Read block. Multiply the parameter value by the memory size, then add up the results to get the total.

**Read Block Template for Mass Dynamic Products**

Name of area	P762 Point	value	Memory size for Read block per value	Result of multiplying value * memory size
Status	1		1	
Rate	2		2	
Load	3		2	
Speed	4		2	
Total	5		4	
Relay Status	6		1	
DI Status	7		1	
SPA	8		8	
Command Control	9		0	
Multispan	10		1	
PID	11		4	
Batch	12		2	
Batch Prewarn	13		2	
Word Order	14		1	
Status 2	15		1	
Batch Total	16		2	
			<b>Total words:</b>	

## Example 1

If you want only rate, load, and batch prewarn, the chart is:

Name of area	P762 Point	value	Memory size for Read block per value	value * memory size
Status	1	0	1	0
Rate	2	1	2	2
Load	3	1	2	2
Speed	4	0	2	0
Total	5	0	4	0
Relay Status	6	0	1	0
DI Status	7	0	1	0
SPA	8	0	8	0
Command Control	9	0	0	0
Multispan	10	0	1	0
PID	11	0	4	0
Batch	12	0	2	0

Name of area	P762 Point	value	Memory size for Read block per value	value * memory size
Batch Prewarn	13	1	2	2
Word Order	14	0	1	0
Status 2	15	0	1	0
Batch Total	16	0	2	0
			<b>Total words:</b>	<b>6</b>

The input data block (Read block) is now 6 words in size (12 bytes) and the Word numbers have shifted to a lower value:

#### New Read Block Data Map

Word	Description
0-1	Rate
2-3	Load
4-5	Batch prewarn

#### Original Read Block Data Map for Mass Dynamic Product

Description	Start	End	Size	Type
instrument status	0	0	1	bitmapped
rate	1	2	2	UINT32
load	3	4	2	UINT32
speed	5	6	2	UINT32
total 1	7	8	2	UINT32
total 2	9	10	2	UINT32
relay status	11	11	1	bitmapped
discrete input status	12	12	1	bitmapped
multispan selection	13	13	1	integer
PID 1 setpoint value	14	15	2	UINT32
PID 2 setpoint value	16	17	2	UINT32
batch setpoint value	18	19	2	UINT32
batch prewarn setpoint value	20	21	2	UINT32
parameter, SPA	22	22	1	integer
primary index, SPA	23	23	1	integer
secondary index, SPA	24	24	1	integer
value, SPA	25	26	2	UINT32
decimal place, SPA	27	27	1	integer
format, SPA	28	28	1	integer
read / write flag, SPA	29	29	1	1/0
word order	30	30	1	1/0
instrument status 2 <sup>1</sup>	31	31	1	bitmapped
batch total <sup>1</sup>	32	33	2	UINT32

1. This is only available in firmware V 3.05 or higher





# Index

---

## A

Alarm and Status 31  
 Application Layer 17  
 Audience 2

## B

Batch Prewarn Setpoint 36  
 Batch Pre-Warn Setpoint Value 40  
 Batch Setpoint 36  
 Batch Setpoint Value 40  
 Baud rate (P751) 13  
 Bit Values 42

## C

Cable  
     connector 7  
 Command Control, Operational Commands 35  
 Communication parameters 13  
 Communication Setup 11  
 Compatibility 4  
 Compatible Devices 3  
 Configuration Status 39

## D

Data Access Methods 18  
 Data Map  
     level products 21  
     Milltronics BW 500 33  
 Data Types 42  
     Bit Values 42  
     integer 42  
     Numeric 42  
     P111 Values 45  
     Split Values 43  
     text messages 44  
     UIN32 43  
 Decimal Place 22, 23, 26, 28, 29, 32, 34  
 Device  
     compatibility 4  
 Device Type 11  
 DeviceNet 1  
 DIP Switches 7  
 Discrete Input Status 40

## E

EDS Files 12  
 EnviroRanger ERS 500  
     connection 8

## F

Factory setting 13  
 Flag 26, 32  
 Format 23, 26, 28, 29, 32, 34  
 Freeze 35

## I

Index 26, 32  
     alarm and status 31  
     MPA 19  
     point reading 25, 31  
     primary 17  
     secondary 18  
 Indexed Parameters 17  
 Installation 4  
 Instrument Status 38  
 Integer 42

## L

LEDs 9  
 Level Products  
     data map 21  
 Load 39

## M

Mark 18  
 Mass Dynamics  
     data map 33  
 Master Reset 20  
 Measurement Point Status 25, 31  
 Milltronics BW 500  
     data map 33  
 MPA  
     overview 19  
     parameter indexing 19  
     using 19  
 Multiple Parameter Access 19  
 Multispan Selection 36, 40

## N

Numeric Values 42



- O**
- Operating Mode 24, 29
- Operation 9
- P**
- P751 13
- P752 13
- P999 20
- Parameter 23, 28, 34
- Parameter Indexes 17
- Parameter Number 22, 26, 28, 32, 40
- Parameter Number and Secondary Index 25, 32
- Parameter Secondary Index 22, 28
- Parameters 13
- PID 1 Setpoint Value 40
- PID 2 Setpoint Value 40
- PID Mode 35
- PID Setpoints 36
- PID Status 38, 41
- Point 17, 26, 32
- Point Alarm and Status 31
- Point Reading 25, 31
- Point-on-Priority 22, 27
- Primary Index 17, 19, 23, 28, 34, 40
- Print 36
- Print Status 38
- Product code 11
- Program Mode 39
- R**
- Rate 39
- Read
  - mass dynamics products 37
- Read/Write Flag 24, 29, 34
- Reading 25, 31
  - EnviroRanger 30
  - level products 24
  - MPA 19
  - SPA 20
- Relay Function Codes 45
- Relay Status 40
- Resistor
  - termination 7
- Returned Values 25, 32
- Run Mode Types 18
- S**
- Safety Notes 2
- Secondary Index 18, 19, 23, 29, 34, 40
- Setpoint Source 35
- Setup Procedure 12
- Single Parameter Access 20
- SPA
  - overview 20
  - reading 20
  - using 20
  - writing 20
- Span 36
- Span Status 38
- Specifications 3
- Speed 39
- Split Values 43
- Status 9
- T**
- Terminal Block
  - connector 7
- Termination Switch 7
- Text Messages 44
- Total 1 39
- Total 2 39
- Totalizer Reset 36
- Totalizer Status 38
- Totalizing Status 39
- Troubleshooting 47
- U**
- UINT32 43
- Unsigned Double Precision Integer 43
- Using
  - MPA 19
  - SPA 20
- V**
- Value 23, 26, 29, 32, 34, 41
- Vendor ID 12
- W**
- Wiring
  - connector 7
- Word Order 37, 41
- Write
  - mass dynamics products 33
- Write Privileges 39
- Writing 20
  - EnviroRanger 27
  - level products 21
- Z**
- Zero 35
- Zero Status 38

[www.siemens-milltronics.com](http://www.siemens-milltronics.com)

Siemens Milltronics Process Instruments Inc.  
1954 Technology Drive, P.O. Box 4225  
Peterborough, ON, Canada K9J 7B1  
Tel: (705) 745-2431 Fax: (705) 741-0466  
Email: [techpubs@siemens-milltronics.com](mailto:techpubs@siemens-milltronics.com)

©Siemens Milltronics Process Instruments Inc. 2003  
Subject to change without prior notice



Printed in Canada

**Rev. 2.0**