

Instruction Manual • April 2004

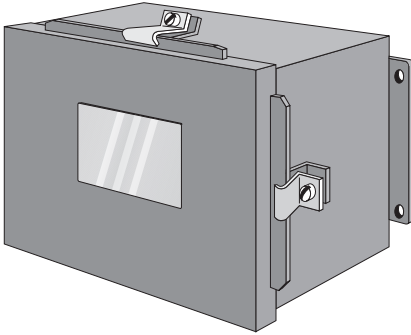

# milltronics

LVDT CARD

**SIEMENS**

## Safety Guidelines

Warning notices must be observed to ensure personal safety as well as that of others, and to protect the product and the connected equipment. These warning notices are accompanied by a clarification of the level of caution to be observed.

## Qualified Personnel

This device/system may only be set up and operated in conjunction with this manual. Qualified personnel are only authorized to install and operate this equipment in accordance with established safety practices and standards.

**Warning:** This product can only function properly and safely if it is correctly transported, stored, installed, set up, operated, and maintained.

**Note:** Always use product in accordance with specifications.

**Copyright Siemens Milltronics Process Instruments Inc. 2004. All Rights Reserved**

**Disclaimer of Liability**

This document is available in bound version and in electronic version. We encourage users to purchase authorized bound manuals, or to view electronic versions as designed and authored by Siemens Milltronics Process Instruments Inc. Siemens Milltronics Process Instruments Inc. will not be responsible for the contents of partial or whole reproductions of either bound or electronic versions.

While we have verified the contents of this manual for agreement with the instrumentation described, variations remain possible. Thus we cannot guarantee full agreement. The contents of this manual are regularly reviewed and corrections are included in subsequent editions. We welcome all suggestions for improvement.

Technical data subject to change.

MILLTRONICS® is a registered trademark of Siemens Milltronics Process Instruments Inc.

Contact SMPI Technical Publications at the following address:

Technical Publications  
Siemens Milltronics Process Instruments Inc.  
1954 Technology Drive, P.O. Box 4225  
Peterborough, Ontario, Canada, K9J 7B1  
Email: [techpubs@siemens-milltronics.com](mailto:techpubs@siemens-milltronics.com)

For the library of SMPI instruction manuals, visit our Web site: [www.siemens-milltronics.com](http://www.siemens-milltronics.com)

# Specifications

---

## Power:

- $\pm 5$  V dc (typically from a Milltronics integrator)

## Ambient Temperature:

- -40 to 50 °C (-40 to 122 °F)

## Input:

- 0 to 1.0 Vac from LVDT based belt scale or solids flow meter

## Output:

- 0 to 50m Vdc to Milltronics BW 100 or BW 500/SF 500  
(maximum 300 m (1000 ft) separation between Conditioner Card and Integrator).
- Accuracy: 0.1% of range

## Enclosure:

- General Purpose Type 4/Nema 4

## Approvals:

- CE

## Cable:

- LVDT Conditioner Card to Integrator: Belden 8404, 4 conductor, shielded 20 AWG or equivalent, 150m (500 ft) max.  
Belden 9260, 6 conductor, shielded 20 AWG or equivalent, 300 m (1000 ft) max.
- LVDT to LVDT Conditioner Card (CT connection not required): Belden 8404, 4 conductor, shielded 20 AWG or equivalent, 300 m (1000 ft) max.

# The LVDT Conditioner Card

The LVDT (Linear Variable Differential Transformer) Conditioner Card is an ancillary piece of equipment. The LVDT Conditioner Card provides all the complex circuitry required to allow the Milltronics BW 100 or BW 500 to interface with a position transducer (LVDT) based scale.

It also allows the SF 500 to interface with a position transducer (LVDT) based solids flowmeter.

## General Operation

The Milltronics BW 100 or BW 500/SF 500 supplies the excitation for the LVDT Conditioner Card, which in turn supplies the excitation for the LVDT.

In belt scale operations the LVDT signal is proportional to material loading. The LVDT signal is converted to a 0-50mVdc signal then applied to the Load Cell A input of the Milltronics BW 100 or BW 500 and used with the speed signal to produce an integral rate signal.

In solids flowmeter applications, the LVDT signal is proportional to the material flow rate. The LVDT signal is converted to a 0-50mV dc signal then applied to Load Cell A input of the Milltronics SF 500 and used to produce an integral rate signal.

## Interconnection

### Connection to Milltronics BW 100

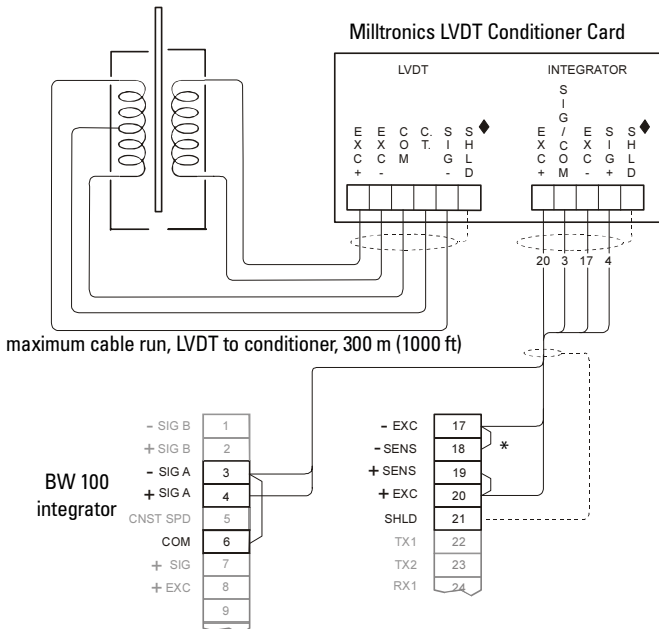

# Connection to a BW 500/SF 500

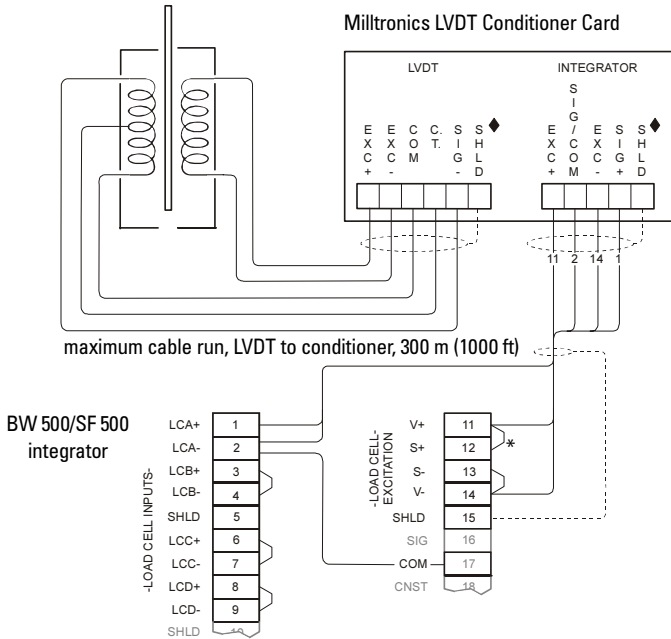

\* Where separation between the integrator and LVDT conditioner exceeds 150 m (500 ft):

- remove the jumpers BW 500/SF 500 terminal 11/12 and 13/14, or BW 100 terminal 17/18 and 19/20

- run additional conductors from:

BW 500/SF 500 terminal 12, or Milltronics BW 100 terminal 19, to conditioner terminal block marked **Integrator +EXC**

BW 500/SF 500 terminal 13, or Milltronics BW 100 terminal 18, to conditioner terminal block marked **Integrator -EXC**

For further connection information on specific LVDTs, consult Siemens Milltronics. See [www.siemens-milltronics.com](http://www.siemens-milltronics.com) for a representative near you.

- ◆ Shields are common, but not grounded to chassis. Run cable shields through SHLD terminals and ground at integrator only.

The LVDT Conditioner Card is also available in a smaller configuration for mounting within the solids flowmeter sensing head.

# Installation

## Top View

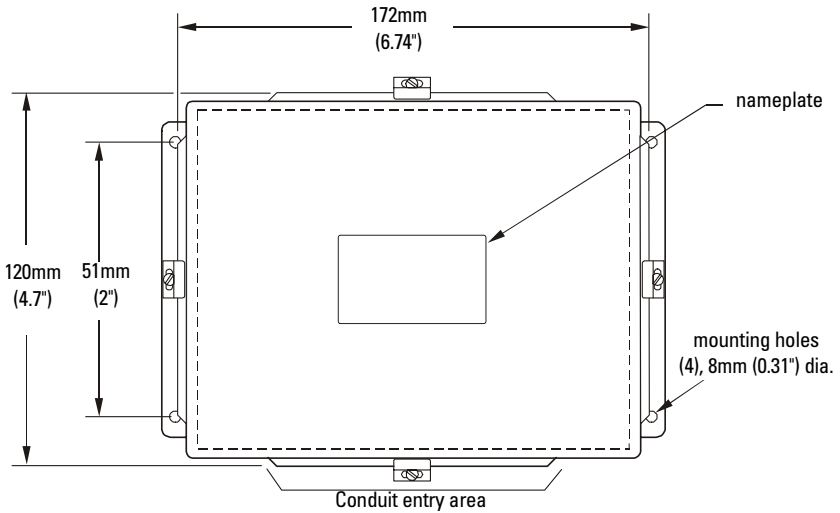

For conduit connection, recommend making holes with punch, and the use of suitable cable glands to maintain ingress protection.

## Front View

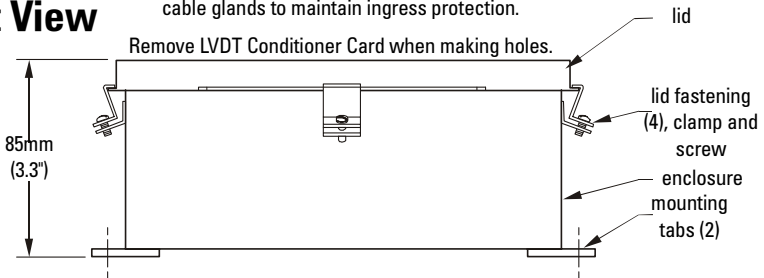





[www.siemens-milltronics.com](http://www.siemens-milltronics.com)

Siemens Milltronics Process Instruments Inc.  
1954 Technology Drive, P.O. Box 4225  
Peterborough, ON, Canada K9J 7B1  
Tel: (705) 745-2431 Fax: (705) 741-0466  
Email: [techpubs@siemens-milltronics.com](mailto:techpubs@siemens-milltronics.com)

© Siemens Milltronics Process Instruments Inc. 2004  
Subject to change without prior notice



Printed in Canada

**Rev. 1.2**