

Instruction Manual • November 2008



million
in one

milltronics

MBS BELT SCALE

SIEMENS

Safety Guidelines: Warning notices must be observed to ensure personal safety as well as that of others, and to protect the product and the connected equipment. These warning notices are accompanied by a clarification of the level of caution to be observed.

Qualified Personnel: This device/system may only be set up and operated in conjunction with this manual. Qualified personnel are only authorized to install and operate this equipment in accordance with established safety practices and standards.

Unit Repair and Excluded Liability:

- The user is responsible for all changes and repairs made to the device by the user or the user's agent.
- All new components are to be provided by Siemens Milltronics Process Instruments Inc.
- Restrict repair to faulty components only.
- Do not reuse faulty components.

Warning: This product can only function properly and safely if it is correctly transported, stored, installed, set up, operated, and maintained.

This product is intended for use in industrial areas. Operation of this equipment in a residential area may cause interference to several frequency based communications.

Note: Always use product in accordance with specifications.

Copyright Siemens Milltronics Process Instruments Inc. 2008. All Rights Reserved	Disclaimer of Liability
This document is available in bound version and in electronic version. We encourage users to purchase authorized bound manuals, or to view electronic versions as designed and authored by Siemens Milltronics Process Instruments Inc. Siemens Milltronics Process Instruments Inc. will not be responsible for the contents of partial or whole reproductions of either bound or electronic versions.	While we have verified the contents of this manual for agreement with the instrumentation described, variations remain possible. Thus we cannot guarantee full agreement. The contents of this manual are regularly reviewed and corrections are included in subsequent editions. We welcome all suggestions for improvement. Technical data subject to change.

MILLTRONICS® is a registered trademark of Siemens Milltronics Process Instruments Inc.

Contact SMPI Technical Publications at the following address:

Technical Publications
Siemens Milltronics Process Instruments Inc.
1954 Technology Drive, P.O. Box 4225
Peterborough, Ontario, Canada, K9J 7B1
Email: techpubs.smpi@siemens.com

European Authorized Representative

Siemens AG
Industry Sector
76181 Karlsruhe
Deutschland

- For a selection of Siemens Milltronics level measurement manuals, go to: **www.siemens.com/processautomation**. Under Process Instrumentation, select *Level Measurement* and then go to the manual archive listed under the product family.
- For a selection of Siemens Milltronics weighing manuals, go to: **www.siemens.com/processautomation**. Under Weighing Technology, select *Continuous Weighing Systems* and then go to the manual archive listed under the product family.

Table of Contents

Milltronics MBS Belt Scale	1
The Manual	1
Specifications	3
Outline Dimensions	5
Side View	5
Front View	6
Conveyor Considerations	7
Control Gates	7
Conveyor Belting	7
Head Pulley	7
Conveyor Curvature	10
Belt Ploughs	10
Stacker Conveyors	11
Conveyor Trippers	11
Skirt Boards and Sealing Strips	11
Installation	12
Welding	12
Load Cell Handling	12
Installation Procedure	13
MBS Wiring	16
Calibration	17
Balancing	17
Test Load	17
Final Calibration	18
Material Test	19
Maintenance	19

Milltronics MBS Belt Scale

Milltronics MBS is a basic, modular, medium-duty belt scale providing dynamic weighing information for process indication. The MBS includes a left and a right weigh beam, with one load cell each.

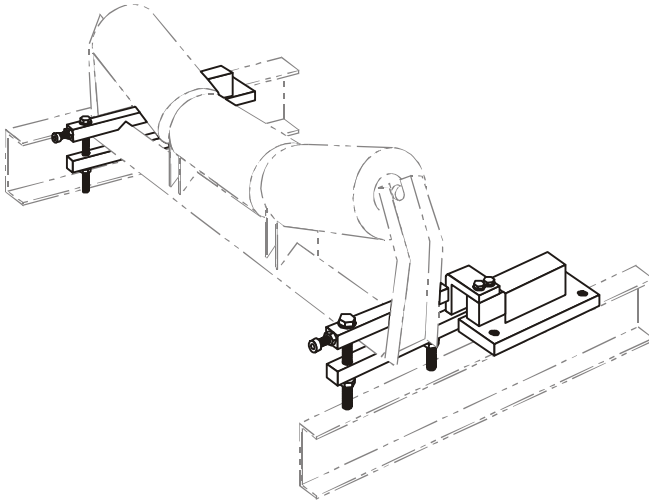

An idler (supplied and installed by customer), test weight bracket and test weights (ordered separately) complete the weighing assembly. The MBS load cells provide an electric signal proportional to load, which is fed to the integrator. Weighing occurs without interrupting the process or affecting the process material.

The MBS belt scale operates in conjunction with an integrator and optional speed sensor.

The Manual

This instruction manual covers the installation, operation and maintenance of the Milltronics MBS belt scale.

We strongly recommend that you read this manual before installing and starting up any component of the weighing system to which the MBS is being applied. Adhering to the installation and operating procedures ensures a quick, trouble-free installation and allows for the maximum accuracy and reliability of your weighing system.

This manual covers only MBS installation and operating procedures. Integrator and speed sensor instruction manuals are available for download from www.siemens.com/processautomation.

We always welcome suggestions and comments about manual content, design, and accessibility. Please direct your comments to techpubs.smpi@siemens.com.



WARNING:

- The Milltronics MBS Belt Scale is to be used only in the manner outlined in this manual, otherwise protection provided by equipment may be impaired.

Note: This product is intended for use in industrial areas. Operation of this equipment in a residential area may cause interference to several frequency based communications.

Specifications

Note: This section provides details on the MBS belt scale.

Accuracy¹

- $\pm 1\%$ of totalization over 33 to 100% operating range, application dependent

Load Cell

- excitation: 10 V DC nominal
15 V DC maximum
- output: 2 +/- 0.02 mV/V excitation at rated load cell capacity
- non-linearity: 0.02% of rated output
- hysteresis: 0.02% of rated output
- non-repeatability: 0.01% of rated output
- capacity: 30, 50, 100 kg (66, 110, 220 lbs)
- overload: safe 150% of rated capacity, ultimate 200% of rated capacity
- temperature: -30 to 70 °C (-22 to 158 °F) operating range
-10 to 40 °C (15 to 105 °F) compensated
- mounting dimensions: see Outline Dimensions
- material: aluminum

Belt Width

- up to 1000 mm (CEMA width up to 42")
- refer to the outline dimension section

Belt Speed²

- up to 3 m/s (600 fpm)

Capacity

- up to 1500 t/h (1650 STPH) at maximum belt speed

-
1. Accuracy subject to: On factory approved installations the belt scale system's totalized weight will be within the specified accuracy when compared to a known weighed material test sample. The test rate must be within the specified range of the design capacity and held constant for the duration of the test. The minimum material test sample must be equivalent to a sample obtained at the test flow rate for three revolutions of the belt or at least ten minutes running time, whichever is greater.
 2. Contact Siemens application engineering for consideration of higher belt speeds.

Conveyor Incline

- $\pm 20^\circ$ from horizontal, fixed incline
- up to $\pm 30^\circ$ with reduced accuracy

Idler Profile

- flat to 35°
- up to 45° with reduced accuracy

Idler Diameter

- 50 to 150 mm (2 to 6")

Idler Spacing

- 0.6 to 1.5 m (2.0 to 5.0 ft)

Weight

- up to 12 kg (26 lbs), 6 kg (13 lbs) per side

Interconnecting Wiring (to integrator)

- < 150 m (500 ft) 0.75 mm^2 (18 AWG) 6 conductor shielded cable
- > 150 m (500 ft) to 300 m (1000 ft) 0.75 to 0.34 mm^2 (18 to 22 AWG) 8 conductor shielded cable

Hazardous Locations

- contact your local Siemens representative

Approvals

- CE, C-TICK

Outline Dimensions

Side View

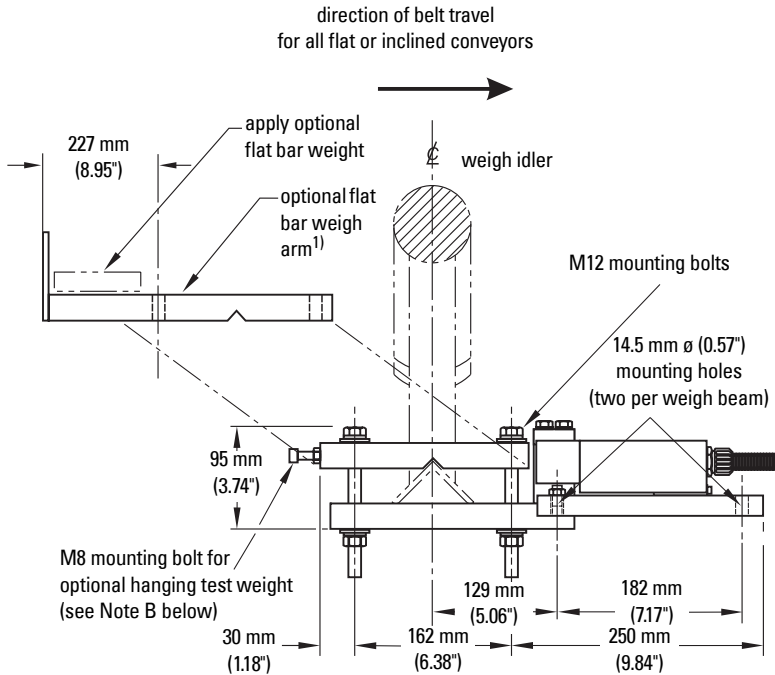

¹⁾ Not recommended for declined conveyor applications

Note:

- A (2) approach and (2) retreat idlers should be aligned with the weigh idler to within $+1/32"$ (0.8 mm) to $-0"$ (0 mm). Contact your Siemens representative with any questions.
- B Test weights (customer supplied), may be hung on the M8 bolts. If this method is chosen, equal mass should be applied to each weigh beam, and the test weights should hang free of the fixed structure.

Front View

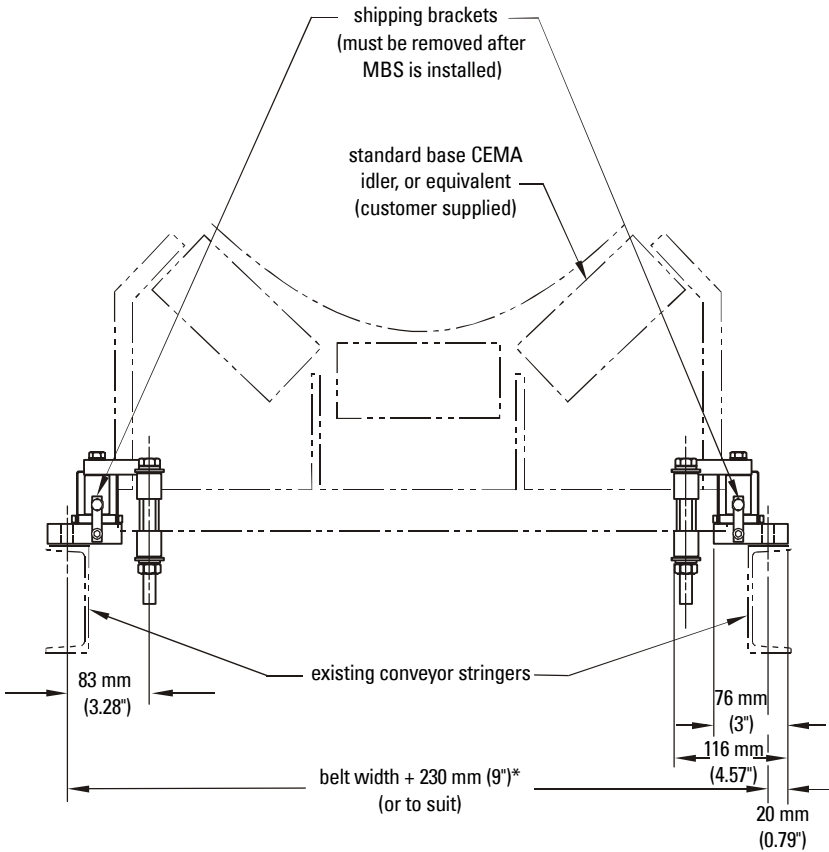

* based on CEMA sizes

Conveyor Considerations

The ideal placement of the Milltronics MBS Belt Scale depends on the conveyor system. This section provides guidelines to determine MBS placement.

Control Gates

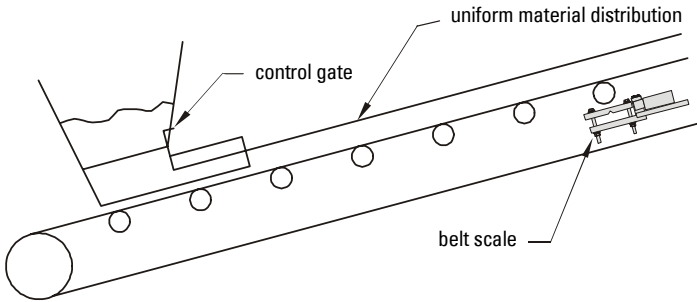

Note: Ensure steady and uniform material loading to the belt at or near the same speed as the conveyor belt. The installation of a material feed control gate or similar device improves uniform flow of material.

Conveyor Belting

Variations in the number of belt plies, the cover thickness and the type and number of splices in a given belt cause considerable change in the weight per unit length of the belt. During the course of zero calibrations, belt scales average the weight of the belt over one complete circuit of the belt. Large deviations from the average adversely affect the zero calibrations.

Head Pulley

Use caution when installing a scale in a short conveyor, or when locating the scale near the head pulley. Since head pulleys are flat faced, and carrying idlers are generally troughed, the belt profile must change from troughed to flat in a short distance. To accommodate this, the conveyor manufacturer designs a built-in vertical displacement of the head pulley above the top of the center roll of the adjacent idler. To further ease this transition, idlers of decreasing trough angles are inserted between the head pulley and the normal run of idlers. If these measures are not taken, a considerable amount of stress is exerted on the belt edges and the idlers adjacent to the head pulley. The stress is transmitted to the scale.

Recommendation: On conveyors with 20° trough idlers throughout, a minimum of two fixed 20° idlers must be located between the scale idler and the head pulley.

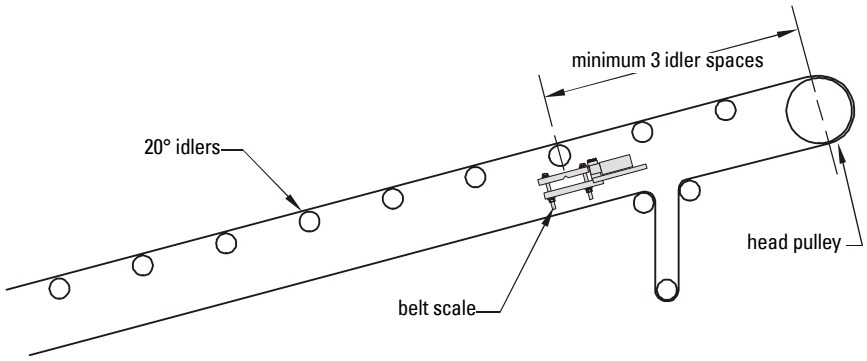

Recommendation: On conveyors with 35° trough idlers throughout, a minimum of two 35° and one 20° retreat idlers must be located between the scale and the head pulley.

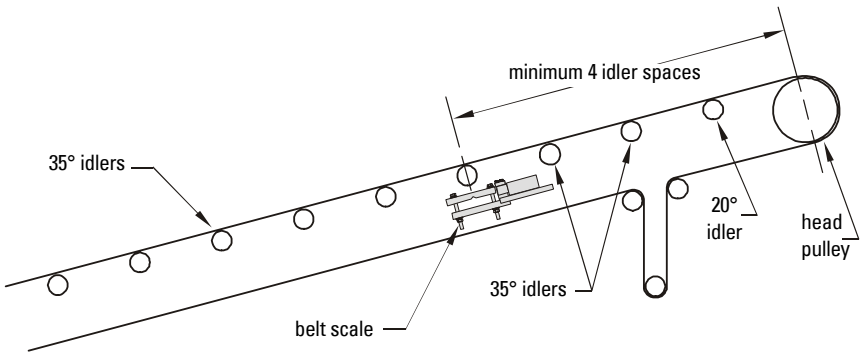

Recommendation: On conveyors with 45° trough idlers throughout, a minimum of two 45°, one 35°, and one 20° retreat idlers must be located between the scale and the head pulley.

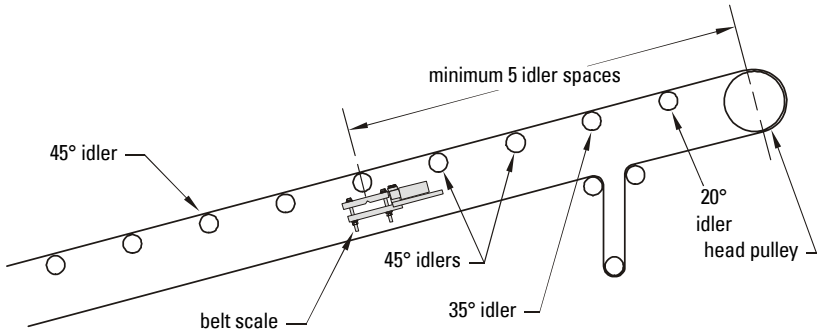

Recommendation: The vertical displacement of the head pulley relative to the adjacent retreat idler is normally in excess of that which is acceptable for belt scale installations. It is suggested that when locating the scale close to the head pulley, a maximum of 13 mm (1/2") vertical displacement between the top of the head pulley and the top of the center roll of the adjacent roll be allowed.

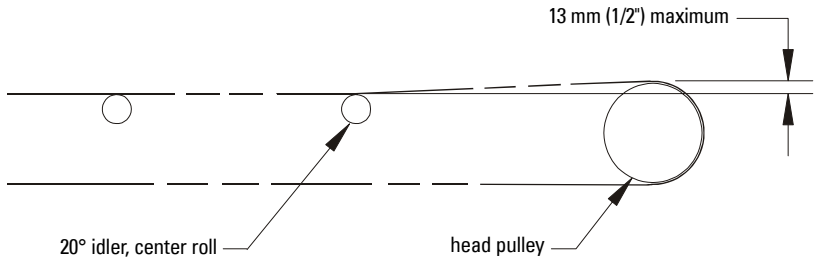

Conveyor Curvature

Vertical curvature (varied heights on one belt) is common in conveyor design, but creates difficulties for belt scales if not dealt with correctly. The curvature, whether concave (internal) or convex (external), disturbs the idler alignment, if the scale is installed in the area of curvature. The concave curve tends to lift the belt off of the idlers in the area of curvature as belt loading decreases, adversely affecting the zero calibration.

Recommendation:

Avoid locating the scale within the tangents of scale curvature.

Concave

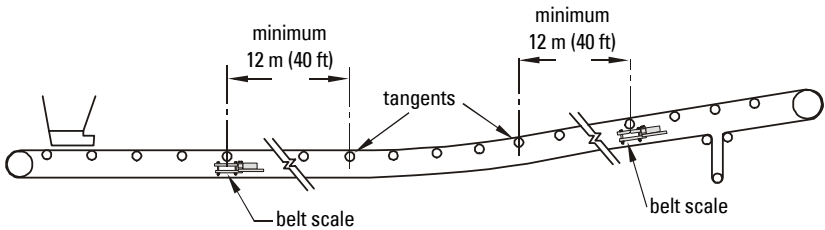

Convex

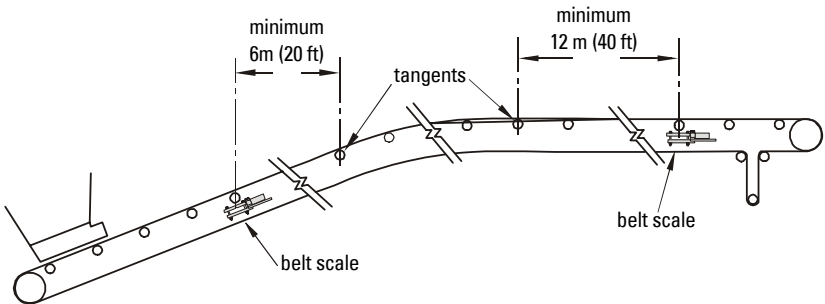

Belt Ploughs

The use of belt ploughs or any conveyor or material control device that changes the profile of the carrying belt in or near the scale area is not recommended. These devices can negatively affect the belt scale idler alignment and usually create drag on the belt which the scale senses as a material force of load.

Recommendation:

Do not install the scale within 9 m (30 ft) of belt ploughs or similar devices that contact the material or belt.

Stacker Conveyors

Any conveyor that is not a permanent structure, which varies in its incline, elevation or profile is not considered a good installation for an accurate belt scale. A belt scale can be used effectively in this conveyor type, but requires special setup.

Conveyor Trippers

Not as common as a conveyor with vertical curvature, trippers can still be troublesome to scales.

Recommendation:

On a conveyor with a tripper car, locate the scale under the recommendations for vertical curves, but with the tripper fully retracted.

Skirt Boards and Sealing Strips

Sometimes it is necessary to extend the infeed skirt boards and sealing strips the full length of the conveyor. This can create problems in weighing accuracy if the sealing strips exert excess force when contacting the belt and indirectly upon the idlers, especially where pinching occurs. The situation adversely affects the zero calibrations

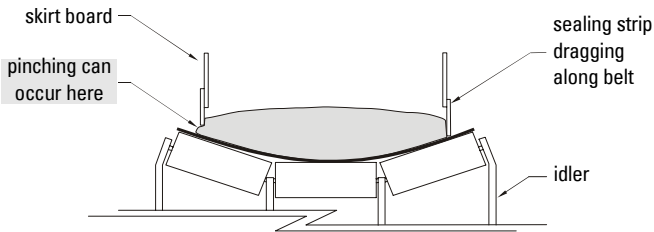

Recommendation:

If possible, remove skirting in scale area. If not, adjust skirting so sealing strip does not put excess force on the belt or allow pinching of material.

Installation

Welding

! **CAUTION:** Use extreme caution when arc welding in the area of the belt scale. To avoid damaging the load cells, ensure that no welding currents can flow through the belt scale.

Load Cell Handling

Load cells are sensitive electro-mechanical transducers and must be handled with care. They can tolerate very little mechanical deflection without damage.

Lift the scale by the stringer mounting flanges of the weigh beam only.

Do not lift the scale by the idler or idler mounting brackets. Never subject the scale to sudden impacts or shocks.

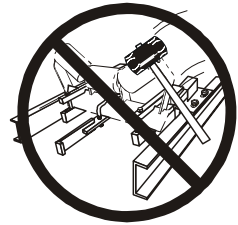
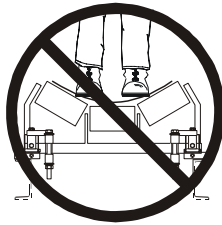

Installation Procedure

1. Remove the idler at the chosen location on the conveyor.

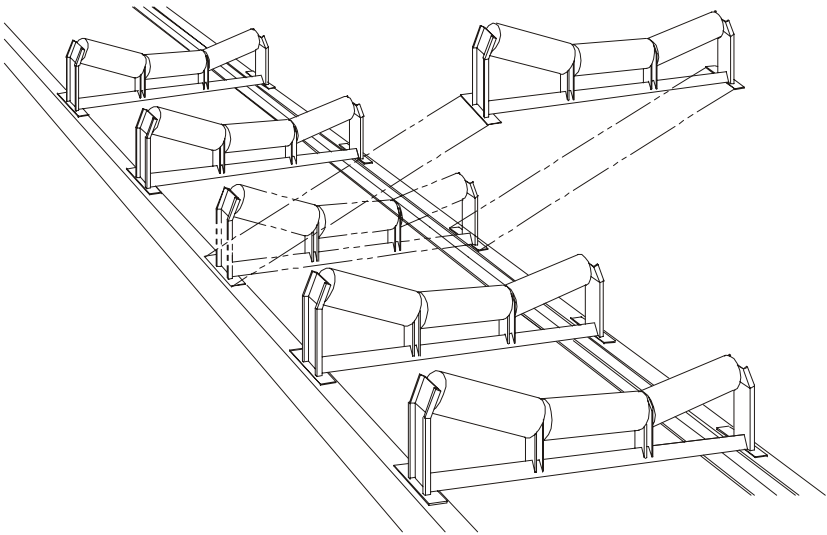

2. Remove the idler foot plates and cut the spine as shown.

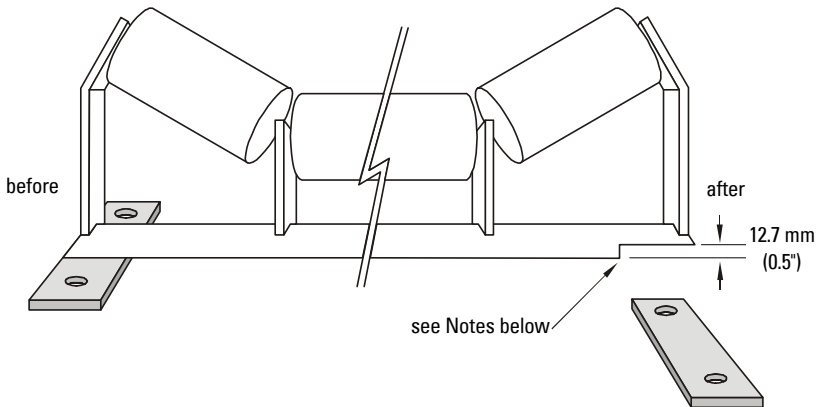

Notes:

- A Cut idler support as shown to allow clearance when the load is applied.
- B Maximum allowable idler spine for fitting to an MBS is:

Angled spine: 75 mm (3")



Channel spine: 145 mm (5.75")



- Position the weigh beams so that the center of the scale idler is centered between the adjacent approach and retreat idlers.

Ensure that the scale is centered and square to the stringers.

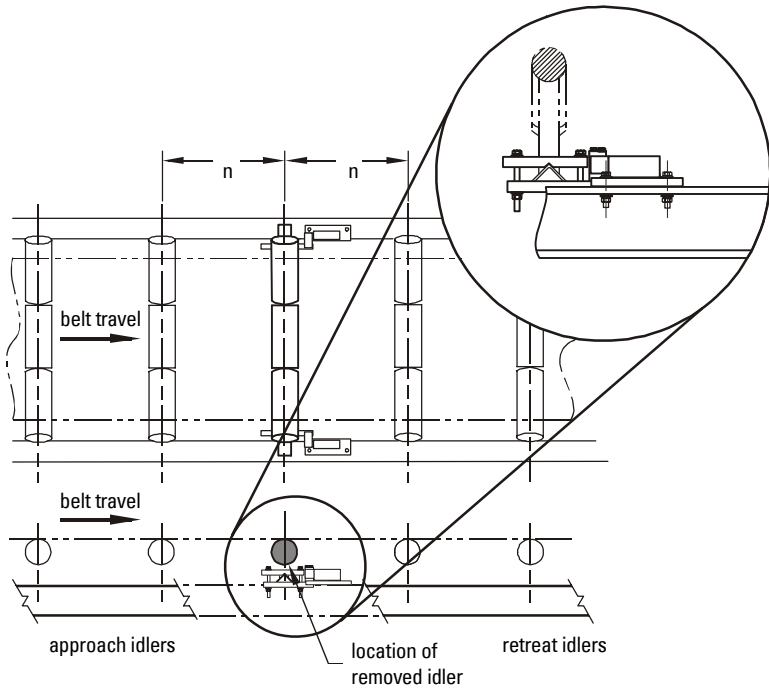

- Mark the position and make new mounting holes suited for M12 (1/2") bolts. Refer to the Outline Dimensions.
- Place the scale weigh beams on each side of the conveyor stringers, with the arrows on each weigh beam pointing in the direction of belt travel (retreat idlers), and mount the modified idler onto the scale using the idler clamping bracket.

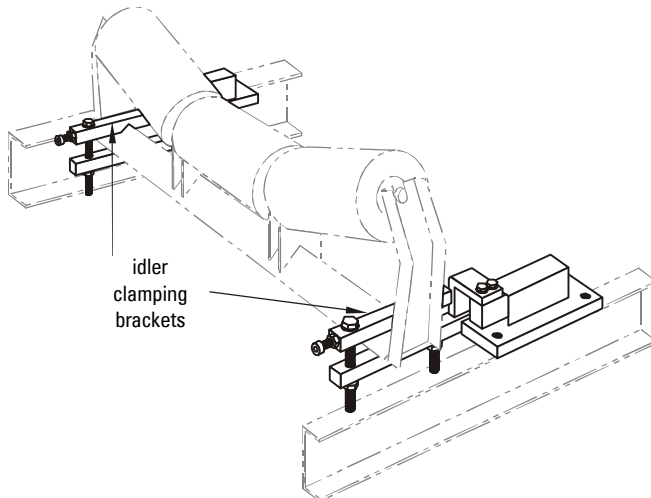

- The idlers in the weighing area (A2 through R2) must be aligned to and square to the stringers, and levelled to a common reference such as a string or wire (refer to subsequent figures). Ensure that the reference is taut (no sagging). If necessary, shim these idlers to be in line with the reference.

Note: Shipping bracket must be removed prior to aligning the idlers in the weighing area.

Alignment and levelling are important parts of the installation procedure and have a direct effect on scale performance. Proper care and attention is recommended.

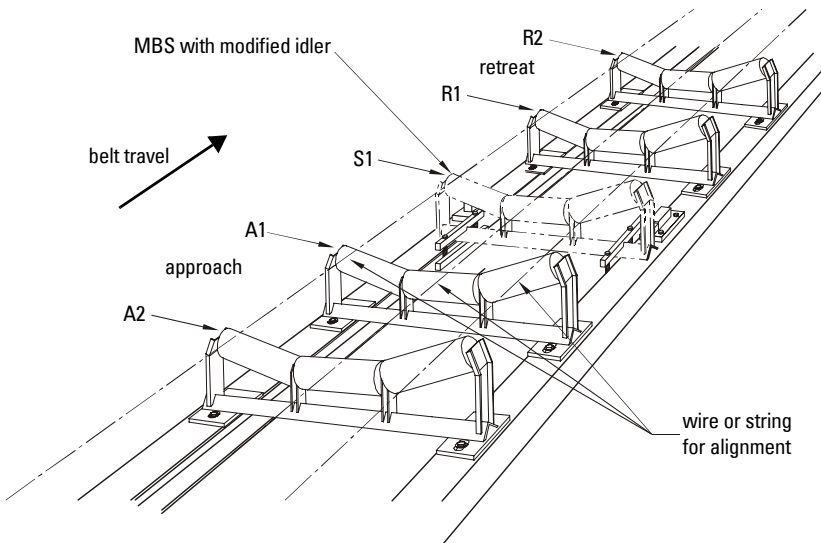
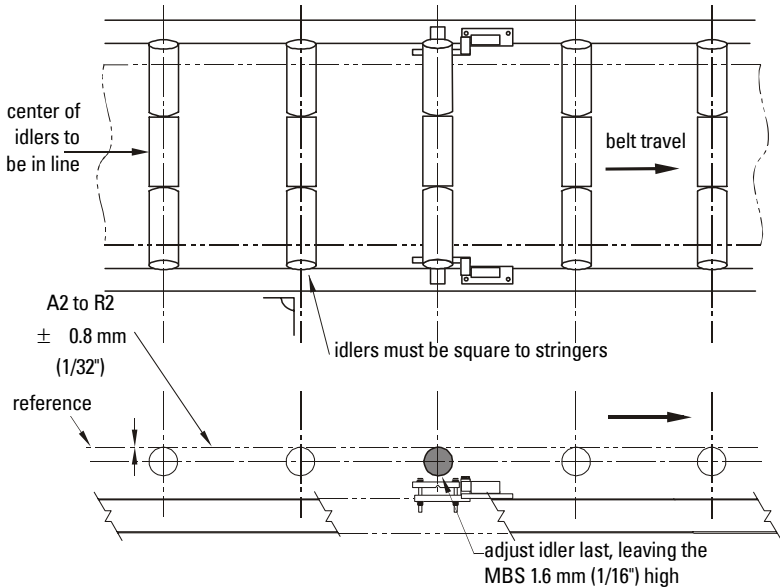

MBS Wiring

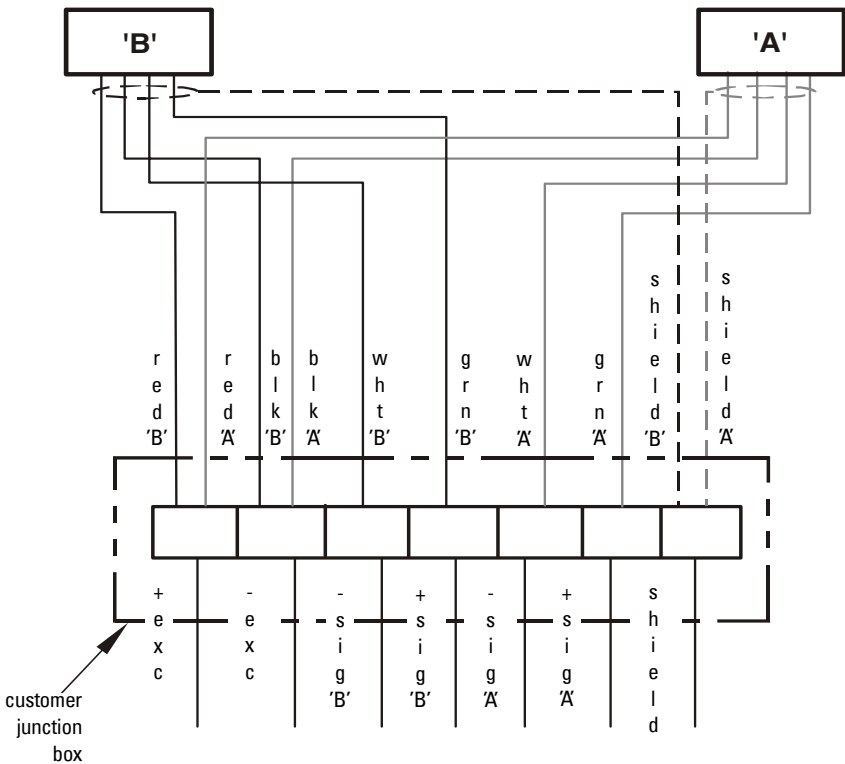
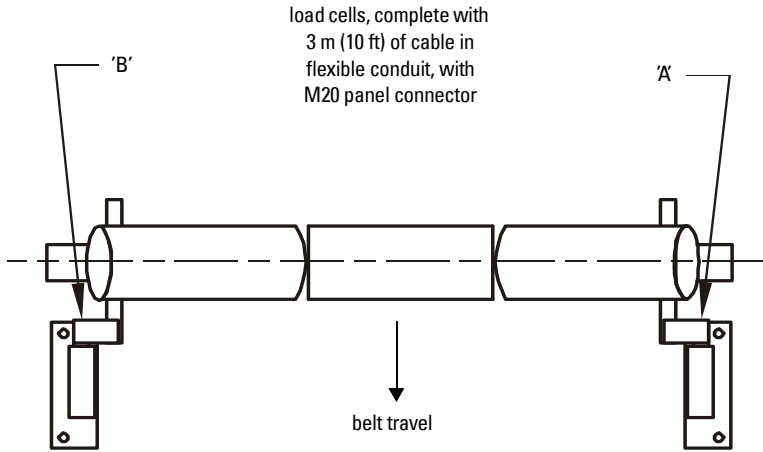

Calibration

After the MBS, the speed sensor, and the integrator have been properly installed and wired, calibration of the weighing system must be done in conjunction with the integrator. Refer to the integrator instruction manual for programming and calibration. The calibration is initially done using the test weight(s). Material tests are recommended to achieve the greatest accuracy.

Balancing

For applications where the conveyor loading does not repeat in locations across the width of the belt, such as side-to-side loading, electronic balancing of the two load cells is recommended. Balancing is completed during the initial start-up, but should be repeated if either load cell is reinstalled or replaced. Refer to the associated integrator manual to complete the balancing procedure.

Permanently fix the test weight bracket toward the centre of the idler on the most accessible side of the conveyor. When balancing load cells, apply a test weight to the extreme sides (side A or B), as required. For use with optional flat bar, apply weights to idler clamping brackets as illustrated on page 5.

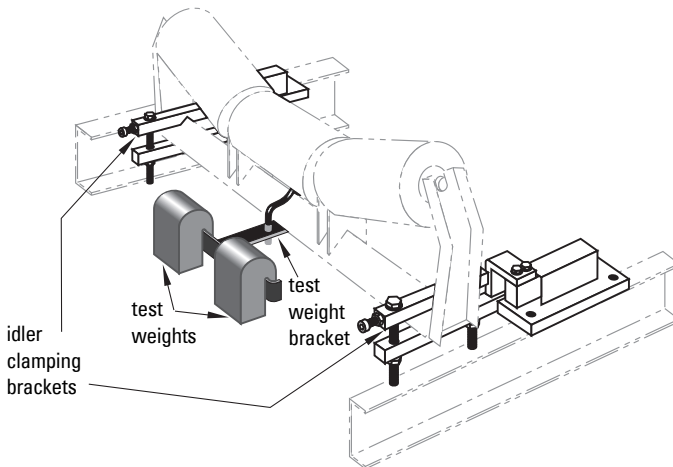

Note: The Balancing feature is not available with SIWAREX FTC.

Test Load

The test load value is required for calibration of the integrator. The calculated value is entered into the associated programming parameter of the integrator, in kilograms per meter or pounds per foot.

The test load value is calculated as follows:

$$\text{Test load} = \frac{\text{test weight mass}}{\text{idler spacing}} \quad \frac{\text{kg}}{\text{m}} \quad \text{or} \quad \frac{\text{lb}}{\text{ft}}$$

Where: idler spacing = $L/2$ [minimum 0.6 m (2.0 ft)]

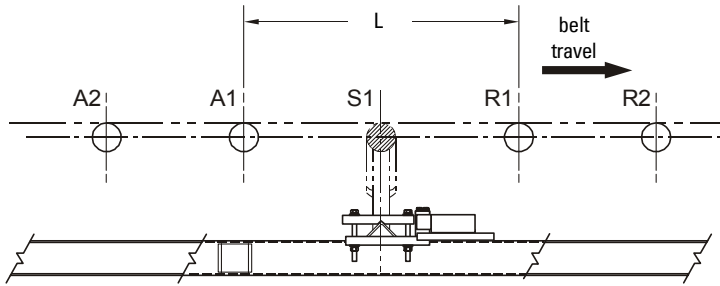

Final Calibration

Once the installation and load cell balancing are completed, the belt can be released and allowed to ride normally on the conveyor. Install the belt speed sensor as described in its instruction manual, and interconnect the speed sensor and belt scale with the belt scale integrator (as shown in its instruction manual, and the system interconnection diagram).

Program the belt scale integrator as suggested in its instruction manual and with parameters suitable for the application. With programming complete, the system is ready for calibration.

A zero calibration can be performed after sufficient running of the conveyor allows the belt to limber up and take its natural formation. A zero calibration is performed in accordance to the belt scale integrator instruction manual with the conveyor running empty.

Zero

Perform the zero calibration as described in the Calibration section of the integrator manual.

After the completion of the zero calibration, a span calibration, as described in the belt scale integrator instruction manual, can be performed with the test weight(s) applied. Be sure to stop the conveyor when applying and removing the test weight.

Span

1. The span reference (test load) is simulated using the test weight.
2. Place the test weight onto the test weight bracket.
3. Perform the span calibration as described in the Calibration section of the integrator instruction manual.

After completing the span calibration, remove the test weight and store it.

With a successful zero and span calibration, and with the test weight(s) removed from the belt scale, the MBS belt scale system is ready for operation. Ensure that the belt scale integrator is left in RUN mode.

Material Test

To achieve accuracy with respect to absolute values, perform material tests. Refer to the associated integrator manual.

Re-Rating

If the rate, speed or idler spacing is changed from the original design, you may need to re-program the integrator. Please contact your regional Siemens Milltronics service office.

Maintenance

The MBS is virtually a maintenance-free device.

In dusty or granular applications, periodically check the load cell stops for material build-up. Remove any build-up in the mechanism to ensure that the load cell maintains free movement.

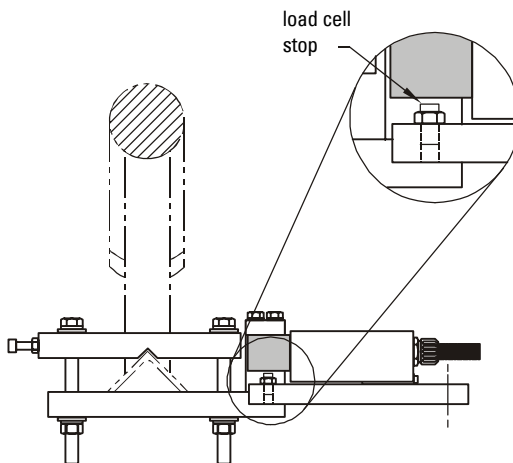

Note: The load cell stop is set at the factory to allow the load cell to deflect up to 150 % of its design load. Maximum gap approximately 0.8 mm (0.030").

Index

B

Balancing	
information	17
Belt Ploughs	
recommendations	10
Belt Speed	
specifications	3
Belt Width	
specifications	3

C

Calibration	
information	17
Capacity	
specifications	3
Components	
list	1
Concave curve	
recommendations	10
Control Gates	
recommendations	7
Convex curve	
recommendations	10
Conveyor Belting	
recommendations	7
Conveyor considerations	7
Conveyor Curvature	
recommendations	10
Conveyor Idler	
specifications	4
Conveyor Incline	
specifications	3
Conveyor Trippers	
recommendations	11
Conveyors	
application information	7

F

Final Calibration	
information	18

H

Hazardous Locations	
specifications	4
Head Pulley	
recommendations	7

I

Idler Diameter	
----------------	--

specifications	4
Idler Spacing	
specifications	4
Installation	
information	12
procedure	13
Interconnecting Wiring	
specifications	4

L

Load Cell	
specifications	3
Load Cell Handling	
caution	12

M

Material Test	
information	19
MBS	
components	1
MBS belt scale	1

O

Overview	
The manual	1
The MBS	1

R

Recommendations	
belt ploughs	10
concave curve	10
control gates	7
convex curve	10
conveyor belting	7
conveyor curvature	10
conveyor trippers	11
head pulley	7
skirt boards and sealing strips	11
stacker conveyors	11
Re-Rating	
information	19

S

Skirt Boards and Sealing Strips	
recommendations	11
Span	
calibration	18
Specifications	
belt speed	3
belt width	3

capacity	3
conveyor idler	4
conveyor incline	3
harardous locations	4
idler diameter	4
idler spacing	4
interconnecting wiring	4
load cell	3
weight	4
Stacker Conveyors	
recommendations	11
T	
Test Load	
calculation	18
information	17
The manual	1
W	
Weight	
specifications	4
Welding	
caution	12
welding	12
Z	
Zero	
calibration	18



www.siemens.com/processautomation

Siemens Milltronics Process Instruments Inc.
1954 Technology Drive, P.O. Box 4225
Peterborough, ON, Canada K9J 7B1
Tel: (705) 745-2431 Fax: (705) 741-0466
Email: techpubs.smpi@siemens.com

© Siemens Milltronics Process Instruments Inc. 2008
Subject to change without prior notice



Printed in Canada

Rev. 1.2