

- NOTES:**
- 1) REFER TO THE MUS INSTRUCTION MANUAL FOR INSTALLATION AND ALIGNMENT INSTRUCTIONS AND FOR PLACEMENT OF THE BELT SCALE. ALL RECOMMENDATIONS MUST BE FOLLOWED TO ENSURE SCALE ACCURACY. FOR FURTHER INFORMATION PLEASE CONTACT YOUR NEAREST SIEMENS MILLTRONICS REPRESENTATIVE.
 - 2) ALL DIMENSIONS ARE IN INCHES BRACKETS [] DENOTE DIMENSIONS IN mm .
 - 3) EACH MUS SCALE INCLUDES 2 LOAD CELL ASSEMBLIES. EACH LOAD CELL IS CONSTRAINED WITHIN SAFE DEFLECTION LIMITS. SIEMENS MILLTRONICS RECOMMENDS THAT CARE BE TAKEN TO AVOID SHOCKING LOAD CELLS.
 - 4) MUS BELT SCALE AND CONVEYOR SHOULD BE SHELTERED FROM STORM OR DIRECT WIND PRESSURE FOR A MINIMUM DISTANCE OF 30 FT. [9140] BEYOND "A1" AND "R1" IDLER POSITIONS. GUIDE IDLERS MUST NOT BE USED WITHIN 15 FT. [4570] BEYOND "A1" AND "R1" IDLER POSITIONS.
 - 5) CONVEYOR BELT MUST NOT TOUCH ANY PART OF THE BELT SCALE. DECKING IF ANY, MUST BE REMOVED FROM MIDPOINT BETWEEN APPROACH "A1" AND "A2" IDLERS TO MIDPOINT BETWEEN RETREAT "R1" AND "R2" IDLERS.
 - 6) IF WING TYPE SELF CLEANING PULLEYS ARE USED PLEASE CONTACT THE NEAREST SIEMENS MILLTRONICS REPRESENTATIVE.
 - 7) INSTALL MD-256 SPEED SENSOR NEAR SCALE ASSEMBLY TO MINIMIZE WIRE RUN.
 - 8) PLACE CALIBRATION BARS FOR SPAN CALIBRATION ONLY.
 - 9) JUNCTION BOX REQUIRED IF BELT SCALE INTEGRATOR IS MOUNTED REMOTE TO THE BELT SCALE AREA. SEE ELECTRICAL CONNECTION DIAGRAM FOR FURTHER DETAILS.

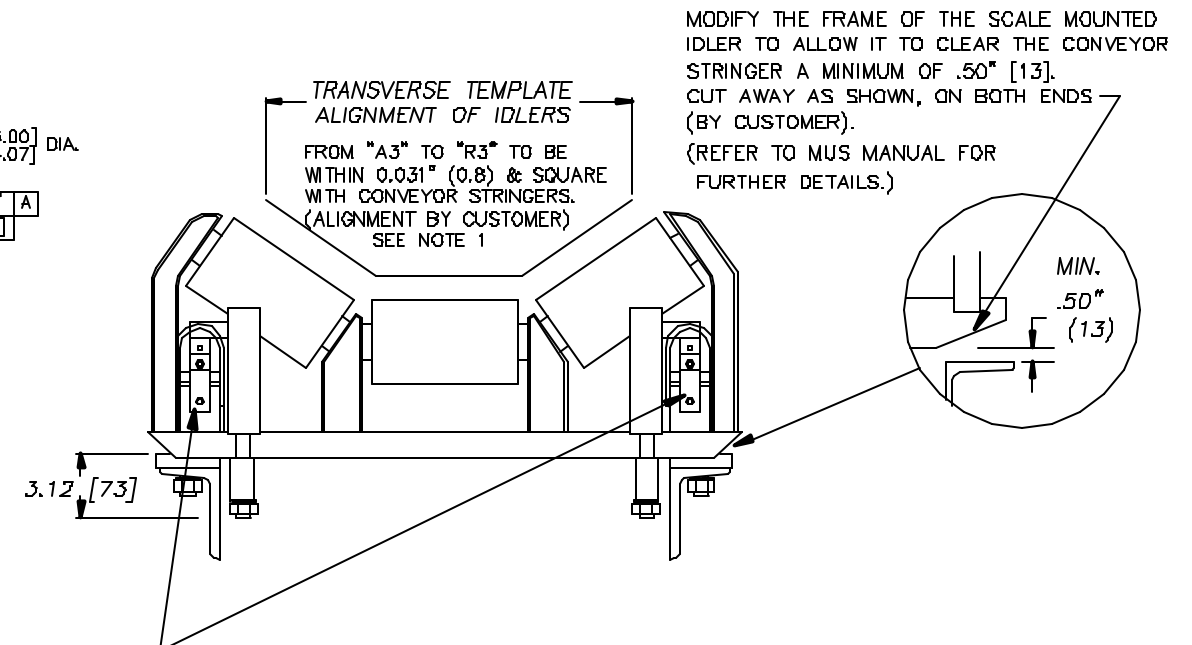
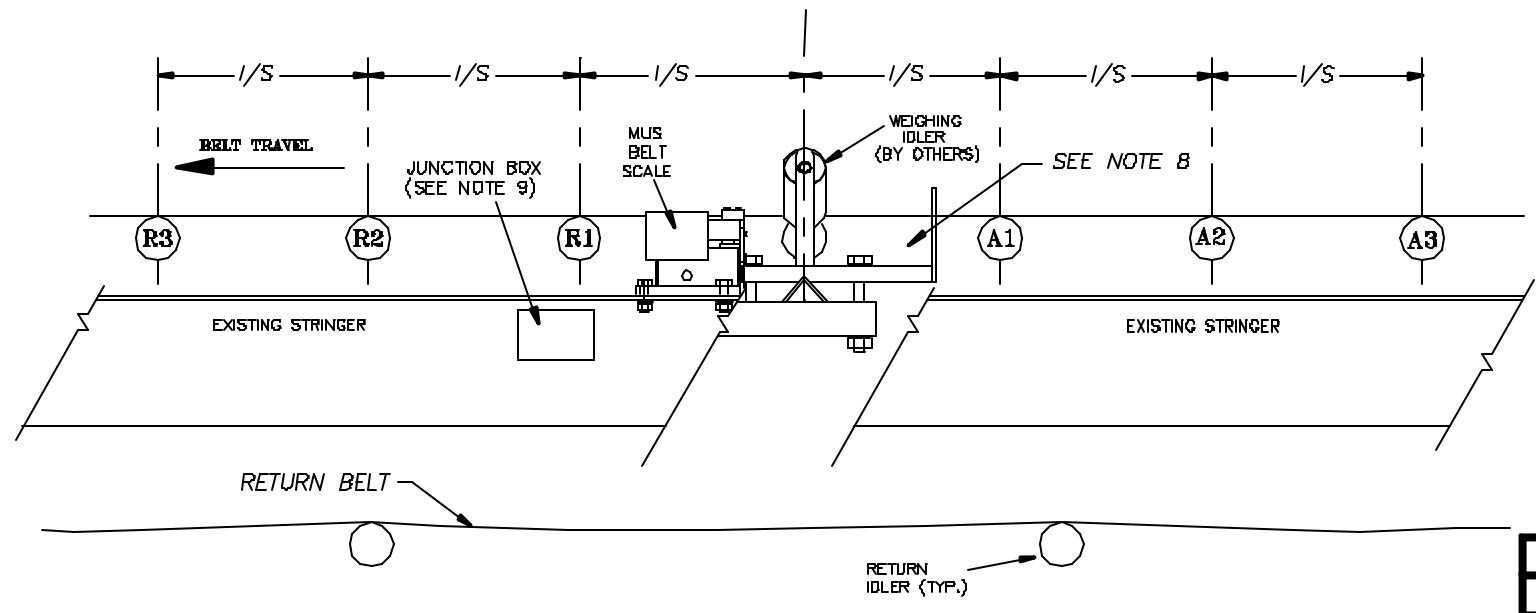

SHIPPING BRACKETS: DO NOT REMOVE SHIPPING BRACKETS UNTIL SCALE IS FULLY INSTALLED. REMOVE BRACKETS BEFORE ALIGNING IDLERS.

NOTE: REMOVE TOP BRACKET SCREW FROM LOAD CELL, THEN LOOSEN BOTTOM BRACKET AND ROTATE SHIPPING BRACKET 90°. RE-TIGHTEN BOTTOM BRACKET BOLT.

USE DIMENSIONS ONLY - DO NOT SCALE		1	REPLACES DRAWING 0-7980006Z-SI-B UPDATED WITH SIEMENS TITLE BLOCK	JLC	RDC	JULY 24/03
DIMENSIONS ARE IN INCHES		Rev.	Revision / ECN Description	Drawn	Appr.	Date
Third Angle Projection 	Product Group	MASS DYNAMICS		Tolerance Unless Otherwise Noted:	U05	Scale:
	Date:	25/01/99		1 Place Decimal ±0.05	Angles: ±0.5°	NONE
FOR INTERNAL USE ONLY	Drawn:	R. CLYSDALE		2 Place Decimal ±0.01		Size:
	Checked:	P. RICCI		3 Place Decimal ±0.002		B
	Approved:	R. CLOSS		TITLE:		
	Location:	PETERBOROUGH		MUS BELT SCALE, STANDARD DUTY WITH MD-256 SPEED SENSOR INSTALLATION DIAGRAM		
	SIEMENS MILLTRONICS PROCESS INSTRUMENTS INC.	Peterborough, Ontario, Canada		DRAWING No:	23650447	
	File No.	2365044701		Pkt at:	1:1	
				Sheet	1 of 1	