

SIEMENS

SIMATIC NET

A5E03275848-04

05/2013

Compact operating instructions

Power supply PS598-1 for SCALANCE XR500

English

Legal information

Qualified Personnel

The product/system described in this documentation may be operated only by **personnel qualified** for the specific task in accordance with the relevant documentation, in particular its warning notices and safety instructions. Qualified personnel are those who, based on their training and experience, are capable of identifying risks and avoiding potential hazards when working with these products/systems.

Proper use of Siemens products

Note the following:

 WARNING
Siemens products may only be used for the applications described in the catalog and in the relevant technical documentation. If products and components from other manufacturers are used, these must be recommended or approved by Siemens. Proper transport, storage, installation, assembly, commissioning, operation and maintenance are required to ensure that the products operate safely and without any problems. The permissible ambient conditions must be complied with. The information in the relevant documentation must be observed.

Warning notice system

This manual contains notices you have to observe in order to ensure your personal safety, as well as to prevent damage to property. The notices referring to your personal safety are highlighted in the manual by a safety alert symbol, notices referring only to property damage have no safety alert symbol. These notices shown below are graded according to the degree of danger.

 DANGER
indicates that death or severe personal injury will result if proper precautions are not taken.

 WARNING
indicates that death or severe personal injury may result if proper precautions are not taken.

 CAUTION
indicates that minor personal injury can result if proper precautions are not taken.

NOTICE
indicates that property damage can result if proper precautions are not taken.

If more than one degree of danger is present, the warning notice representing the highest degree of danger will be used. A notice warning of injury to persons with a safety alert symbol may also include a warning relating to property damage.

Table of contents

1	Introduction	3
2	Safety notes	3
3	Description	4
	3.1 Product characteristics	4
	3.2 Unpacking and checking	5
4	Mounting	6
	4.1 19" rack mounting of the PS598-1.....	6
	4.2 Mounting the PS598-1 on the rear panel of an XR500.....	8
5	Connection	11
	5.1 Connecting devices with 100 to 240 VAC power supply	11
	5.2 LED display	16
6	Upkeep and maintenance	17
7	Technical data	18
8	Dimension drawings	19
9	Approvals	20
	9.1 EMC directive	20
	9.2 Mechanical stability (in operation)	22

1 Introduction

Purpose of the compact operating instructions

Based on the compact operating instructions, you will be able to install and connect up the PS598-1 correctly.

Validity of these compact operating instructions

These compact operating instructions apply to the product PS598-1 as of product version 1.

2 Safety notes

Safety notices on the use of the devices

The following safety notices must be adhered to when setting up and operating the device and during all work relating to it such as installation, connecting up, replacing devices or opening the device.

Important notices 100 to 240 VAC

 DANGER
Danger from line voltage
Devices with this mark have a 100 to 240 VAC power supply.
This product can only function correctly and safely if it is transported, stored, set up, and installed correctly, and operated and maintained as recommended.
Connecting and disconnecting may only be performed by an electrical specialist.
Connect or disconnect power supply cables only when the power is turned off!

General notices

 WARNING
Opening the device
Do not open when energized. Note that this does not apply to opening the panel in the housing.

3 Description

3.1 Product characteristics

Connectors

Type	Power	Input voltage	Output voltage
PS598-1	300 W	100 to 240 VAC	24 VDC

Note

Two connectors for the 24 VDC output voltage

The PS598-1 has two connectors with the output voltage 24 VDC. Note that you can only use one connector on the front or the connector on the rear of the PS598-1. You cannot operate the device with the connectors on the front and rear at the same time.

Note

Requirement for connecting at the rear

Note that the connector on the rear of the PS598-1 can only be used if the power supply is mounted on the SCALANCE XR500.

Components of the product

The following parts make up the components of the PS598-1:

- 4-pin terminal block for the 24 VDC power supply.
- 2 mounting brackets
- 8 screws (M3 x 6 countersunk, drive: Torx) for mounting the fixing brackets for 19" rack installation
- Compact Operating Instructions

Order numbers

Type	Order number
PS598-1 (300 W)	6GK5 598-1AA00-3AA0

Note**Replacing the filter mat**

To replace the filter mat, use the material Viledon P 15/150 G2 EN 779. The dimensions of the filter mat are 38 x 135 x 8 mm (H x W x D).

3.2 Unpacking and checking

<p> WARNING</p> <p>Do not use any parts that show evidence of damage</p> <p>If you use damaged parts, there is no guarantee that the device will function according to the specification.</p> <p>If you use damaged parts, this can lead to the following problems:</p> <ul style="list-style-type: none"> • Injury to persons • Loss of the approvals • Violation of the EMC regulations <p>Use only undamaged parts.</p>
--

1. Make sure that the package is complete.
2. Check all the parts for transport damage.

If the consignment is incomplete or if there is damage to the exterior, contact your supplier or your local Siemens office.

4 Mounting

4.1 19" rack mounting of the PS598-1

Power supply unit for 19" rack installation

The PS598-1 was developed specifically for use with devices of the XR500 product group. This power supply unit can be mounted directly above or below a SCALANCE XR500 since the ventilation grilles are on the sides of both the basic device and the power supply unit.

CAUTION

Risk of injury if subjected to irregular mechanical strain

The device must be mounted in the rack so that even if there is irregular mechanical strain, no dangerous situation can result.

NOTICE

Damage to the device due to inadequate cooling

If the ventilation grilles are fully or partly covered or the air filters are contaminated, the temperature inside the housing can rise and exceed the maximum permitted temperature and damage the device.

During installation, select a mounting position so that the ventilation grilles are always free so that the air can circulate. The ventilation grilles are located on the side panels of the housing. You will find information about cleaning the air filter in the section "Upkeep and maintenance".

Procedure

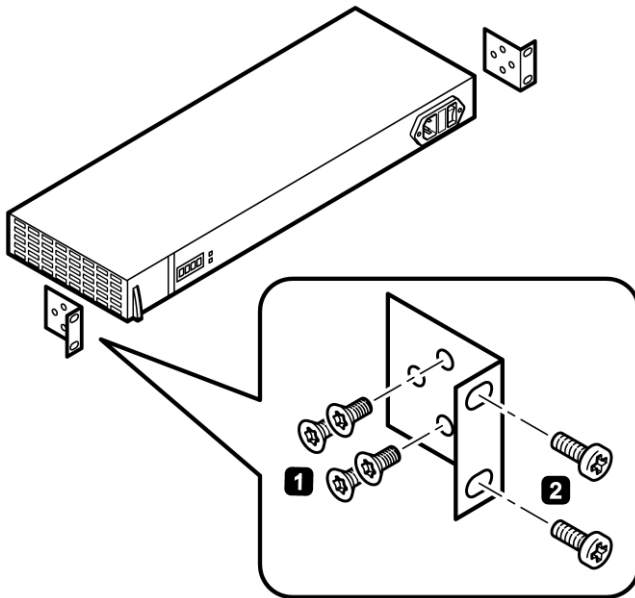

Follow the steps below to install the PS598-1 in a 19" rack:

1. Secure the two mounting brackets with four screws each (M3 x 6 supplied with the product) to the side panels of the power supply unit. The maximum tightening torque for these screws is 0.5 Nm.
2. Screw the PS598-1 to the 19" rack.

4.2 Mounting the PS598-1 on the rear panel of an XR500

NOTICE

Damage to the device due to inadequate cooling

If the ventilation grilles are fully or partly covered or the air filters are contaminated, the temperature inside the housing can rise and exceed the maximum permitted temperature and damage the device.

During installation, select a mounting position so that the ventilation grilles are always free so that the air can circulate. The ventilation grilles are located on the side panels of the housing. You will find information about cleaning the air filter in the section "Upkeep and maintenance".

Procedure

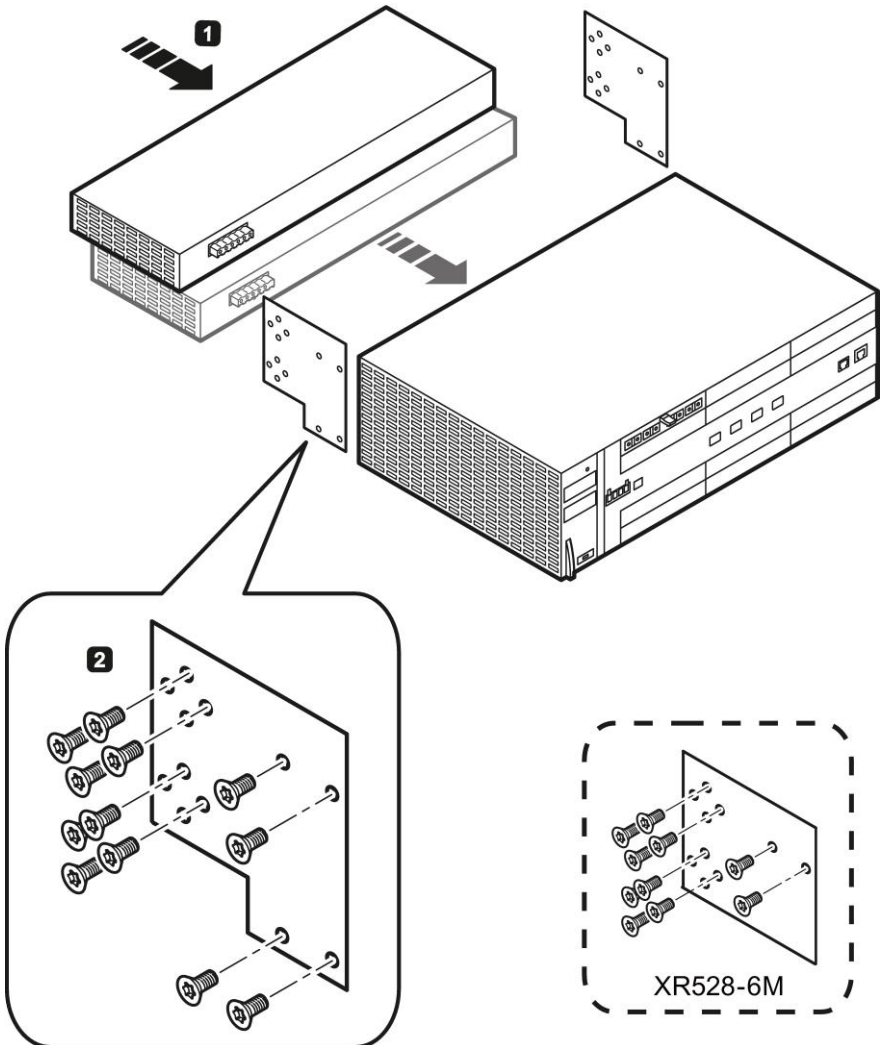

Figure 4-1 Rear panel mounting of the SCALANCE XR552-12M. SCALANCE XR528-6M is used analogously.

Mounting

On the rear panel of a SCALANCE XR500, there are sockets for the direct connection of a maximum of two PS598-1 power supply units. On the rear of the PS598-1 there is a corresponding plug. Follow the steps below to install the PS598-1 on the rear panel of a SCALANCE XR500:

1. Fit the PS598-1 and the SCALANCE XR500 together. The two devices are equipped with positioning elements that must engage during installation and protect the plug from excessive bending strain.
2. Screw the two devices to the mounting plates supplied with the main device. The maximum tightening torque of the screws is 0.5 Nm.

5 Connection

5.1 Connecting devices with 100 to 240 VAC power supply

Switches for the input voltage

The socket X1 (position ①) and the switch S1 Power (position ③) for the input voltage are located on the right-hand side of the front panel of the housing:



NOTICE

Connect and disconnect the power supply unit only when it is not energized!

The PS598-1 is not capable of hot plugging. Connecting or disconnecting the PS598-1 when the 100 to 240 VAC power supply is on can damage the PS598-1 and the SCALANCE XR500.

Before connecting or disconnecting the PS598-1, make sure that the switch for the input voltage is set to position "0".

NOTICE

CAUTION/DOUBLE POLE

The fuses FUSE1 and FUSE2 are in the fuse holder (position ②). The fuses are of the type F6.3AH / 250 VAC.

NOTICE

Overvoltage protection for the power supply cables

If there is any possible overload of the power supply cables, suitable overvoltage protection is necessary. Refer to the values on the type plate.

NOTICE

Reliable grounding

Reliable grounding of the devices mounted in the rack must be guaranteed. This applies, in particular, to power supply cables that are not connected directly to the power supply circuit. With the PS598-1, the IEC power connector (IEC 60320-1) provides the connection to protective earth.

Pin assignment of the X2 socket on the front

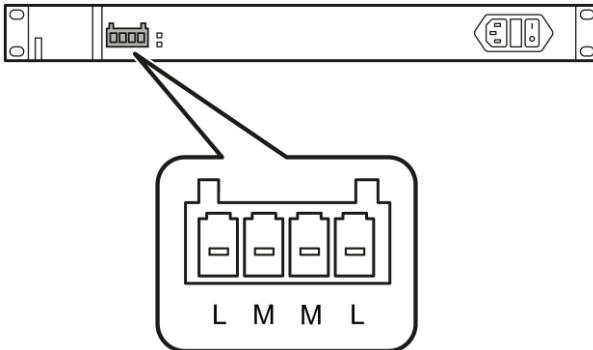

Contact	Assignment
L	+24 VDC
M	Ground
M	Ground
L	+24 VDC

Pin assignment of the X3 plug on the rear

Connector X3 is located on the back of the PS598-1. Connector X3 is intended only to connect the PS598-1 directly to an XR500.

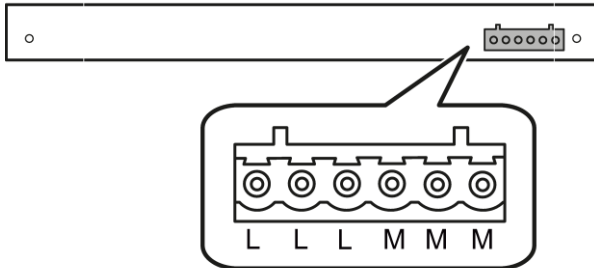

Contact	Assignment
L	+24 VDC
L	
L	
M	Ground
M	
M	

One PS598-1 per device, no redundancy

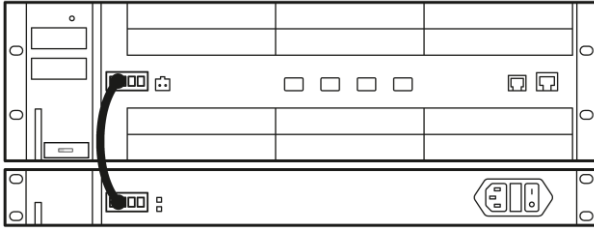

Figure 5-1 Connecting a power supply unit to a SCALANCE XR552-12M. SCALANCE XR528-6M is used analogously.

Connect the SCALANCE XR500 and the PS598-1 with one cable for 24 VDC and a cable for ground. As an alternative, you can also mount the PS598-1 on the back of the SCALANCE XR500 and secure it with screws. In this case, no extra cables are necessary. You will find detailed information in the section "Installation".

Two PS598-1 per device, 1-out-of-2 redundancy

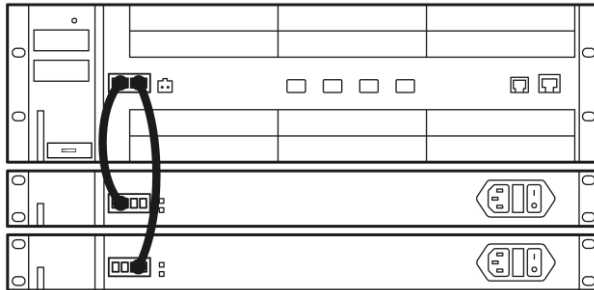

Figure 5-2 Connecting two power supply units to a SCALANCE XR552-12M. SCALANCE XR528-6M is used analogously.

Connect the SCALANCE XR500 and the PS598-1 with one cable for 24 VDC and a cable for ground. As an alternative, you can also mount the two PS598-1 units on the back of the SCALANCE XR500 and secure it with screws. In this case, no extra cables are necessary. You will find detailed information in the section "Mounting (Page 6)". It is also possible to operate the SCALANCE XR500 even after the failure of a PS598-1. The SCALANCE XR500 detects the failure of a power source and signals the failure. The PS598-1 units share the applied load automatically and uniformly.

Three PS598-1 units for two devices - 2-out-of-3 redundancy

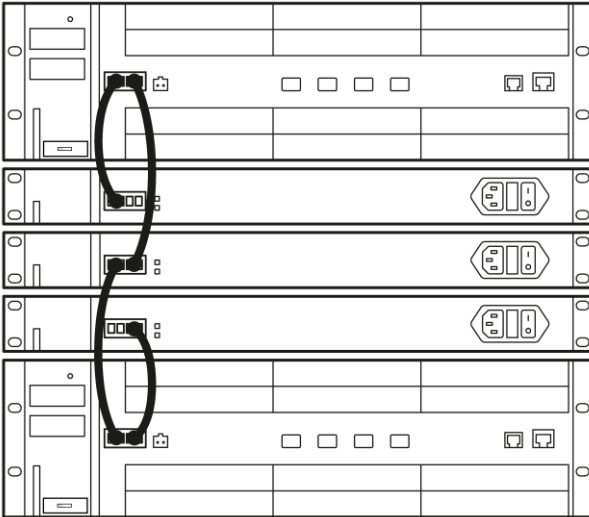

Figure 5-3 Connecting three power supply units to a SCALANCE XR552-12M. SCALANCE XR528-6M is used analogously.

Connect each SCALANCE XR500 to its own PS598-1. In addition to this, connect both SCALANCE XR500 devices to the third PS598-1. Both SCALANCE XR500 devices can now continue to operate after the failure of one PS598-1. The SCALANCE XR500 detects the failure of a power source and signals the failure. The PS598-1 units share the applied load automatically and uniformly.

Note

Two connectors for the 24 VDC output voltage

The PS598-1 has two connectors with the output voltage 24 VDC. Note that you can only use the connector on the front or the connector on the rear of the PS598-1. You cannot operate the device with the connectors on the front and rear at the same time.

Note

To wire up the power supply connector, use copper cable of the category 14 AWG to 10 AWG or cable with a cross-sectional area of 1.5 to to 4 mm².

In areas subject to the NEC or CEC:

 WARNING
Safety notice for connectors with LAN (Local Area Network) marking A LAN or LAN segment, with all its associated interconnected equipment, shall be entirely contained within a single low-voltage power distribution and within a single building. The LAN is considered to be in an "environment A" according to IEEE802.3 or "environment 0" according to IEC TR 62102, respectively. Never connect directly to TNV-circuits (Telephone Network) or WAN (Wide Area Network).

5.2 LED display

LED display

A PS598-1 has two LEDs each, one green and one red. If the green LEDs is lit (24V OK), the output voltage is correctly applied. If the red LED is lit (SHUT DOWN) an error has occurred.

Possible errors/faults:

- The output voltage is not correct.
- Temperature of the PS598-1 is too high.

6 Upkeep and maintenance

The PS598-1 has a service panel, behind which there is a removable air filter. The air filter can be replaced during operation.

Procedure

1. Open the service panel.
2. Take the air filter out of the device.
3. Clean the air filter.
4. Place the cleaned air filter in the device again.
5. Close the panel.

NOTICE

A badly contaminated air filter reduces air flow and can cause the device to be damaged.

Check the degree of contamination of the air filter regularly and clean it when necessary.

7 Technical data

Device variants

The following technical specifications apply to the following device:

- PS598-1

Connectors

Interface	Execution
Power	<ul style="list-style-type: none">• 4-pin terminal block for 2 x 24 VDC on the front of the device.• Plug on the rear of the housing for direct connection to a SCALANCE XR500.

Construction

Property	Value / version / exists
Dimensions without brackets for rack mounting (W x H x D)	446 x 44 x 140 mm (1 height unit)
Weight	1700 g
Surface of the housing	Powder coating
Degree of protection	IP20 (with closed panel in housing)
Installation in a 483 mm rack (19" rack)	Yes
DIN rail mounting	No
S7-300 standard rail mounting	No
Wall mounting	No

Electrical data

Property	Value
Rated power	300 W
Input voltage	100 to 240 VAC / 50/60 Hz
Output voltage	24 VDC
Output current	12.5 A
Input current at 300 W	3,6 ... 1.6 A
Overcurrent protection of the power supply	F6.3 AH / 250 VAC

Environmental conditions

Property	Value
Transportation/storage temperature	-40 °C to +85 °C
Operating temperature	0 °C to +60 °C
Maximum relative humidity in operation at 25 °C	< 95 % no condensation
Operating altitude above sea level depending on ambient temperature	<ul style="list-style-type: none"> • 2000 m at max. 56 °C • 3000 m at max. 50 °C

8 Dimension drawings

View from front and above

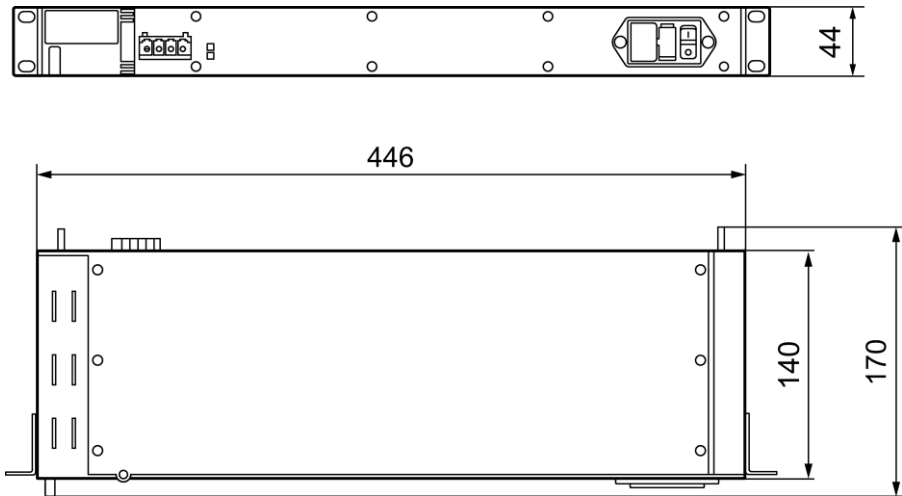

Dimensions are specified in mm.

9 Approvals

The SIMATIC NET products described in these Operating Instructions have the approvals listed below.

Note

Issued approvals on the type plate of the device

The specified approvals apply only when the corresponding mark is printed on the product. You can check which of the following approvals have been granted for your product by the markings on the type plate.

EC directives

SIMATIC NET products meet the requirements and aims of the following EC directives.

9.1 EMC directive

EMC directive (electromagnetic compatibility)

The SIMATIC NET products described in these operating instructions meet the requirements of EC directive 2004/108/EC "Electromagnetic Compatibility" for the following areas of application:

Field of application	Requirements	
	Emission	Immunity to interference
Industry	EN 61000-6-4 : 2007	EN 61000-6-2 : 2005

C-TICK

The product meets the requirements of the AS/NZS 2064 standard (Class A).

 WARNING
Personal injury and property damage can occur The installation of expansions that are not approved for SIMATIC NET products or their target systems may violate the requirements and regulations for safety and electromagnetic compatibility. Only use expansions that are approved for the system.

- **Keep to the installation guidelines**

The product meets the requirements if you adhere to the installation and safety instructions contained in this documentation and in the following documentation when installing and operating the product.

- **You can always find the latest documentation on the Internet**

The current descriptions of the currently available products can always be found on the Internet under the specified entry IDs/Internet pages:

- SIMATIC NET Industrial Ethernet Network manual

ID = 27069465

(<http://support.automation.siemens.com/WW/view/en/27069465>)

- EMC Installation Guideline, Planning Guide

ID = 28518276

(<http://support.automation.siemens.com/WW/view/en/28518276>)

- **Working on the product**

To protect the product from electrostatic discharge, personnel must first discharge any electrostatic charge from their body before touching the product.

Note

The product was tested with a device that also complies with the standards listed above.

If the product is operated with a device that does not meet these standards, there is no guarantee that the corresponding values will be adhered to.

Low voltage equipment directive

Devices supplied with 100 to 240 VAC meet the requirements of the directive 2006/95/EC "Electrical Equipment Designed for Use within Certain Voltage Limits" (Low Voltage Equipment Directive). Conformity attested by compliance with the standard EN 60950-1:2010.

cULus Approval for Information Technology Equipment

cULus Listed I. T. E.

Underwriters Laboratories Inc. complying with

- UL 60950-1 (Information Technology Equipment)
- CSA C22.2 No. 60950-1-03

EU declaration of conformity

You will find the EU declaration of conformity for these products on the Internet under the following entry IDs/Internet page specified here:

ID = 57026840 (<http://support.automation.siemens.com/WWW/view/en/57026840>)

- Entry list
- Entry type "Certificates"
- Type of certificate "Declaration of Conformity"

Example German: "EG-Konformitätserklärung SCALANCE XR552-12M",

Example English: "Declaration of Conformity SCALANCE XR552-12M".

9.2 Mechanical stability (in operation)

Device: SCALANCE	IEC 60068-2-6 vibration)	IEC 60068-2-27 shock	IEC 60068-2-6 vibration
	5 – 9 Hz: 3.5 mm 9 – 150 Hz: 1 g 1 octave/min, 20 sweeps	15 g, 11 ms duration 6 shocks per axis	10 – 58 Hz: 0.075 mm 85 – 150 Hz: 1 g 1 octave/min, 20 sweeps
PS598-1	•	•	•
*) Note: When rack mounted with four securing points			

Trademarks

All names identified by ® are registered trademarks of Siemens AG. The remaining trademarks in this publication may be trademarks whose use by third parties for their own purposes could violate the rights of the owner.

Disclaimer of Liability

We have reviewed the contents of this publication to ensure consistency with the hardware and software described. Since variance cannot be precluded entirely, we cannot guarantee full consistency. However, the information in this publication is reviewed regularly and any necessary corrections are included in subsequent editions.

Siemens AG
Industry Sector
Postfach 48 48
90026 NÜRNBERG

Power supply unit PS598-1 for SCALANCE XR500
A5E03275848, 05/2013