

SIEMENS

SINAMICS

SINAMICS G110D

Parameter Manual

Edition

11/2016

English

Changes to the motor thermal protection feature of the MICROMASTER, SIMATIC & SINAMICS inverters

On 9th November 2010 Underwriters Laboratories Inc.(UL) revised the standard for "safety of power conversion equipment" which covers Siemens inverters. These changes in the standard become effective from the 9th of May 2013.

The changes relate to the performance of the software motor protection offered by the inverter, in that when the inverter is power-cycled it must now retain the motor temperature data for use when power is reapplied.

The following products have had a software update to comply with the new requirements.

- MICROMASTER 420 software V1.3 or above. (Order No. 6SE6420.....)
- MICROMASTER 430 software V2.2 or above. (Order No. 6SE6430.....)
- MICROMASTER 440 software V2.2 or above. (Order No. 6SE6440.....)
- SINAMICS G110 software V1.2 or above. (Order No. 6SL3211.....)
- SINAMICS G110D software V3.6 or above. (Order No. 6SL3511.....)
- SINAMICS Pool CU-2 software V4.6 or above *)
(CU230P-2, CU240E-2, CU240B-2, G120C, CU240D-2, CU250D-2).
- SIMATIC ET200pro FC-2 software V4.7 or above *)

These products now, by default, store the motor temperature (r0034 for SINAMICS G110 and MICROMASTER 420; r0035 for SINAMICS G110D and MICROMASTER 430/440) and re-use this value when power is reapplied:

Parameter P0610 has been changed to reflect this new requirement as follows:

The default value of parameter P0610 is now 6 and the following settings have been added:

- Value 4 = Warning Only, no reaction, no trip, save temperature on power down.
- Value 5 = Warning, I_{max} reduction, trip F0011, save temperature on power down.
- Value 6 = Warning, no reaction, trip F0011, save temperature on power down.

*) Those units have other settings and default values. Please refer to the relevant parameter lists.

The following products will not have the software update to support the new requirements.

- All MICROMASTER 3 variants (Order No. 6SE32.....)
- All MICROMASTER 410 (Order No. 6SE6410.....)
- All MICROMASTER 411 (Order No. 6SE6411.....)
- All MICROMASTER 436 (Order No. 6SE6436.....)
- All MICROMASTER MMI / CM2 (Order No. 6SE96.....)

These products are unchanged from their original design, but this is no longer compliant with the new requirements.

These products may still bear the UL symbol but it is now the end users responsibility to provide listed motor overload protection external to the inverter.

We suggest the end user consider devices such as the Siemens overload relay 3RU series on the motor side of the inverter in order to provide the motor protection, details of which can be found at the link below:

<http://www.automation.siemens.com/mcms/industrial-controls/en/protection-equipment/overload-relays/pages/default.aspx>



A 5 E 3 1 6 7 4 1 4 5 A

Deutsch

Änderung zum thermischen Motorschutz bei Frequenzumrichtern MICROMASTER, SIMATIC und SINAMICS

Ab 9. November 2010 hat "Underwriters Laboratories Inc.(UL)" den Standard "Safety of power conversion equipment" geändert. Davon sind auch Siemens-Frequenzumrichter betroffen. Die Änderung trat am 9. Mai 2013 in Kraft.

Die Änderung bezieht sich auf die Leistungsfähigkeit der Software für den Motorschutz, den der Frequenzumrichter bietet. Wenn bei dem Frequenzumrichter ein "Power-Cycle" durchgeführt wird, muss der Wert der Motortemperatur beim Wiedereinschalten beibehalten werden.

Folgende Produkte erfüllen die neue Anforderung zum thermischen Motorschutz:

- MICROMASTER 420, ab Software V1.3 (Bestell- Nr. 6SE6420.....)
- MICROMASTER 430, ab Software V2.2 (Bestell- Nr. 6SE6430.....)
- MICROMASTER 440, Software V2.2. (Bestell- Nr. 6SE6440.....)
- SINAMICS G110, ab Software V1.2 (Bestell- Nr. 6SL3211.....)
- SINAMICS G110D , ab Software v3.6 (Bestell- Nr. 6SL3511.....)
- SINAMICS Pool CU-2 , ab Software V4.6 *)
(CU230P-2, CU240E-2, CU240B-2, G120C, CU240D-2, CU250D-2).
- SIMATIC ET200pro FC-2 , ab Software V4.7 *)

Dabei wird in der Werkseinstellung die Motortemperatur gespeichert (r0034 für SINAMICS G110 und MICROMASTER 420; r0035 für SINAMICS G110D und MICROMASTER 430/440) und beim Zuschalten der Spannung, also nach einem Power Cycle, für die Berechnung der Motortemperatur verwendet.

Die Änderung wird über folgende Erweiterung des Parameters P0610 realisiert.

Neue Einstellmöglichkeiten:

- Wert 4 = nur Warnung, keine Reaktion, Temperaturwert beim Ausschalten speichern.
- Wert 5 = Warnung, I_{max} reduzieren, Abschaltung mit F0011, Temperaturwert beim Ausschalten speichern.
- Wert 6 = Warnung , keine Reaktion, Abschaltung mit F0011, Temperaturwert beim Ausschalten speichern (**neue Werkseinstellung**)

*) Bei diesen Geräten gibt es andere Einstellmöglichkeiten und Werkseinstellungen. Beachten Sie die entsprechenden Listenhandbücher!

Die folgenden Produkte erfüllen die neue Anforderung zum thermischen Motorschutz nicht:

- Alle MICROMASTER 3 Varianten (Bestell- Nr. 6SE32.....)
- Alle MICROMASTER 410 (Bestell- Nr. 6SE6410.....)
- Alle MICROMASTER 411 (Bestell- Nr. 6SE6411.....)
- Alle MICROMASTER 436 (Bestell- Nr. 6SE6436.....)
- Alle MICROMASTER MMI / CM2 (Bestell- Nr. 6SE96.....)

Am Original Design dieser Produkte hat sich nichts geändert, aber sie erfüllen nicht mehr die neuen UL Vorschriften.

Diese Produkte dürfen am Typenschild ein UL Symbol zeigen, aber es ist in der Verantwortung des Endkunden einen gelisteten externen Motorüberlastschutz einzubauen.

Wir empfehlen dem Endkunden ein Siemens-Überlastrelais der Serie 3RU motorseitig am Frequenzumrichter zu installieren, um den Motorschutz zu gewährleisten.

Weitere Informationen zu den Sirius 3RU-Überlastrelais finden Sie unter folgendem Link:

<http://www.automation.siemens.com/mcms/industrial-controls/de/schutzgeraete/ueberlastrelais/Seiten/default.aspx>



A 5 E 3 1 6 7 4 1 4 5 A

Français

Changement de la fonction de protection thermique du moteur des variateurs de vitesse MICROMASTER & SINAMICS

Le 09 Novembre 2010 Underwriters Laboratories Inc.(UL) ont révisé les standards sur la "sécurité des convertisseurs de puissance" ("safety of power conversion equipment") qui s'appliquent aux variateurs de vitesse Siemens . Ces changements des standards sont effectifs à partir du 09 Mai 2013.

Les changements se rapportent à la performance de la fonction protection thermique du moteur des variateurs de vitesse, en ceci que lorsque le variateur de vitesse est mis hors tension, les données thermiques du moteur doivent désormais être conservées jusqu'à la prochaine mise sous tension et utilisation du produit.

Une mise à jour du software sur les produits suivants a été implémentée afin de se conformer aux nouveaux standards.

- MICROMASTER 420 software V1.3 ou supérieur (Order No. 6SE6420.....)
- MICROMASTER 430 software V2.2 ou supérieur (Order No. 6SE6430.....)
- MICROMASTER 440 software V2.2 ou supérieur (Order No. 6SE6440.....)
- SINAMICS G110 software V1.12 ou supérieur (Order No. 6SL3211.....)
- SINAMICS G110D software V1.3 ou supérieur (Order No. 6SL3511.....)
- SINAMICS Pool CU-2 software V4.6 ou supérieur *)
(CU230P-2, CU240E-2, CU240B-2, G120C, CU240D-2, CU250D-2).
- SIMATIC ET200pro FC-2 software V4.7 ou supérieur *)

Désormais, les produits enregistrent par défaut la température du moteur (r0034 pour SINAMICS G110 et MICROMASTER 420 ; r0035 pour SINAMICS G110D et MICROMASTER 430/440) et réutilisent cette valeur dès que la puissance est rétablie sur l'équipement.

Le paramètre P0610 a été modifié afin de refléter ces changements, comme indiqué ci-dessous :
La valeur par défaut du paramètre P0610 est désormais 6, et les réglages suivants ont été ajoutés :

- Value 4 = Avertissement uniquement, température enregistrée lors de la mise hors tension.
- Value 5 = Avertissement et réduction I_{max}, arrêt F0011, température enregistrée lors de la mise hors tension.
- Value 6 = Avertissement, pas réaction, arrêt F0011, température enregistrée lors de la mise hors tension.

*) Ces appareils ont d'autres possibilités de réglage et d'autres réglages usine. Tenir compte des tables de paramètres !

Les versions de software des produits suivants n'intègrent pas les modifications pour répondre aux nouveaux standards UL.

- tous les MICROMASTER 3 variants (N° de réf. 6SE32.....)
- tous les MICROMASTER 410 (N° de réf. 6SE6410.....)
- tous les MICROMASTER 411 (N° de réf. 6SE6411.....)
- tous les MICROMASTER 436 (N° de réf. 6SE6436.....)
- tous les MICROMASTER MMI / CM2 (N° de réf. 6SE96.....)

Ces produits restent inchangés de leur conception d'origine et ne sont pas conforme à ce nouveau standards UL.

Bien que ces produits aient toujours le marquage UL, les utilisateurs finaux sont maintenant responsables de la mise en place sur le variateur d'équipement externe de protection thermique moteur listés.

Nous recommandons aux utilisateurs externes d'utiliser des relais de protection thermique côté moteur de type Siemens Sirius 3RU.

Plus d'informations sur ces relais sont disponibles sous le lien suivant :

<http://www.automation.siemens.com/mcms/industrial-controls/en/protection-equipment/overload-relays/pages/default.aspx>



Italiano

Modifiche della funzione di protezione termica del motore dei convertitori di frequenza MICROMASTER, SIMATIC e SINAMICS

In data 9 novembre 2010 Underwriters Laboratories Inc.(UL) ha rivisto lo standard per la "sicurezza delle apparecchiature di conversione di potenza" (*safety of power conversion equipment*) che si applica ai convertitori di frequenza Siemens. Queste modifiche della norma sono entrate in vigore il 9 maggio 2013.

Le variazioni riguardano le caratteristiche della protezione software del motore offerte dal convertitore di frequenza: quando quest'ultimo viene spento e riacceso deve ora memorizzare i dati termici del motore per riutilizzarli al momento della riaccensione.

I prodotti seguenti hanno implementato un aggiornamento del software per conformarsi ai nuovi requisiti normativi.

- MICROMASTER 420 software V1.3 o successiva. (n. di ordinazione 6SE6420.....)
- MICROMASTER 430 software V2.2 o successiva. (n. di ordinazione 6SE6430.....)
- MICROMASTER 440 software V2.2 o successiva. (n. di ordinazione 6SE6440.....)
- SINAMICS G110 software V1.2 o successiva. (n. di ordinazione 6SL3211.....)
- SINAMICS G110D software V3.6 o successiva. (n. di ordinazione 6SL3511.....)
- SINAMICS Pool CU-2 software V4.6 o successiva *)
(CU230P-2, CU240E-2, CU240B-2, G120C, CU240D-2, CU250D-2).
- SIMATIC ET200pro FC-2 software V4.7 o successiva *)

Tali prodotti memorizzano adesso sistematicamente la temperatura del motore (r0034 per SINAMICS G110 e MICROMASTER 420; r0035 per SINAMICS G110D e MICROMASTER 430/440) e riutilizzano questo valore alla riaccensione:

Il parametro P0610 è stato modificato come segue per tenere conto di questo nuovo requisito:
Il valore predefinito del parametro P0610 è diventato 6 e sono state aggiunte le seguenti impostazioni:

- Valore 4 = solo avviso, nessuna reazione, nessuna disinserzione, memorizzazione della temperatura allo spegnimento.
- Valore 5 = solo avviso, riduzione I_{max}, disinserzione F0011, memorizzazione della temperatura allo spegnimento.
- Valore 6 = solo avviso, nessuna reazione, disinserzione F0011, memorizzazione della temperatura allo spegnimento.

*) Queste unità presentano impostazioni e valori predefiniti differenti. Fare riferimento alla lista parametri corrispondente.

I prodotti seguenti non implementeranno l'aggiornamento software e di conseguenza non supporteranno i nuovi requisiti.

- Tutte le varianti MICROMASTER 3 (n. di ordinazione 6SE32.....)
- Tutti i MICROMASTER 410 (n. di ordinazione 6SE6410.....)
- Tutti i MICROMASTER 411 (n. di ordinazione 6SE6411.....)
- Tutti i MICROMASTER 436 (n. di ordinazione 6SE6436.....)
- Tutti i MICROMASTER MMI / CM2 (n. di ordinazione 6SE96.....)

Questi prodotti restano invariati rispetto alla loro progettazione originale, ma non sono più compatibili con i nuovi requisiti.

Questi prodotti possono mantenere il simbolo UL, ma compete all'utente finale assicurare la protezione esterna contro i sovraccarichi del motore richiesta dalla norma per il convertitore di frequenza.

Per assicurare la protezione del motore si consiglia all'utente finale di ricorrere a dispositivi come i relè di sovraccarico Siemens della serie 3RU sul lato motore del convertitore di frequenza. Per i dettagli fare riferimento al link seguente:

<http://www.automation.siemens.com/mcms/industrial-controls/en/protection-equipment/overload-relays/pages/default.aspx>



A 5 E 3 1 6 7 4 1 4 5 A

Cambios en la función de protección térmica del motor de los convertidores MICROMASTER, SIMATIC y SINAMICS

El 9 de noviembre de 2010, Underwriters Laboratories Inc. (UL) revisó el estándar de "seguridad de los equipos convertidores de energía", que afecta a los convertidores de Siemens. Estos cambios en el estándar entraron en vigor el 9 de mayo de 2013.

Los cambios están relacionados con el rendimiento de la protección del motor por software ofrecida por el convertidor, por la cual, cuando el convertidor se apaga y se vuelve a encender, debe conservar los datos sobre la temperatura del motor para utilizarlos al volver a arrancar.

Para cumplir con los nuevos requisitos, se ha actualizado el software de los productos siguientes.

- Software MICROMASTER 420 V1.3 o superior. (Ref. 6SE6420.....)
- Software MICROMASTER 430 V2.2 o superior. (Ref. 6SE6430.....)
- Software MICROMASTER 440 V2.2 o superior. (Ref. 6SE6440.....)
- Software SINAMICS G110 V1.2 o superior. (Ref. 6SL3211.....)
- Software SINAMICS G110D V3.6 o superior. (Ref. 6SL3511.....)
- Software SINAMICS Pool CU-2 V4.6 o superior *)
(CU230P-2, CU240E-2, CU240B-2, G120C, CU240D-2, CU250D-2).
- Software SIMATIC ET200pro FC-2 V4.7 o superior. *)

De forma predeterminada, estos productos almacenan la temperatura del motor (r0034 para SINAMICS G110 y MICROMASTER 420; r0035 para SINAMICS G110D y MICROMASTER 430/440) y reutilizan ese valor al volver a arrancar:

El parámetro P0610 se ha modificado para reflejar este nuevo requisito de la forma siguiente:

El valor predeterminado del parámetro P0610 ahora es 6, y se han añadido los siguientes ajustes:

- Valor 4 = Solo aviso, sin reacción, sin disparo, guardar temperatura al apagar.
- Valor 5 = Aviso, reducción $I_{m\acute{a}x}$, disparo F0011, guardar temperatura al apagar.
- Valor 6 = Aviso, sin reacción, disparo F0011, guardar temperatura al apagar.

*) Estas unidades tienen otros ajustes y valores predeterminados. Consulte las listas de parámetros pertinentes.

Los productos siguientes no dispondrán de la actualización de software para cumplir los nuevos requisitos.

- Todas las variantes de MICROMASTER 3 (Ref. 6SE32.....)
- Todos los MICROMASTER 410 (Ref. 6SE6410.....)
- Todos los MICROMASTER 411 (Ref. 6SE6411.....)
- Todos los MICROMASTER 436 (Ref. 6SE6436.....)
- Todos los MICROMASTER MMI/CM2 (Ref. 6SE96.....)

Estos productos no han sufrido cambios respecto a su diseño original, pero ya no cumplen los nuevos requisitos.

Estos productos todavía pueden llevar el símbolo UL, pero ahora es responsabilidad de los usuarios finales proporcionar una protección homologada contra sobrecarga del motor externa al convertidor.

Para la protección del motor, recomendamos al usuario final dispositivos como el relé de sobrecarga de la serie 3RU de Siemens en el lado del motor del convertidor. Puede encontrar información detallada en el enlace siguiente:

<http://www.automation.siemens.com/mcms/industrial-controls/en/protection-equipment/overload-relays/pages/default.aspx>



SIEMENS

SINAMICS SINAMICS G110D

Parameter Manual

Fundamental safety instructions	1
Parameters	2
Function diagrams	3
Faults and Alarms	4
ASCII-Table	A
List of Abbreviations	B
Index	C

This Parameter Manual is valid for the
Firmware version V3.7

A5E39615340B AA

Edition 11/2016

Legal information

Warning notice system

This Manual contains information which you must observe to ensure your own personal safety as well as to avoid material damage. The notices referring to your personal safety are highlighted in the manual by a safety alert symbol, notices referring only to equipment damage have no safety alert symbol. Depending on the hazard level, warnings are indicated in a descending order as follows:

 DANGER
indicates that death or serious injury will result if proper precautions are not taken.

 WARNING
indicates that death or serious injury could result if proper precautions are not taken.

 CAUTION
indicates that minor personal injury can result if proper precautions are not taken.

NOTICE
indicates that property damage can result if proper precautions are not taken.

If more than one level of danger is simultaneously applicable, the warning notice for the highest level is used. A notice warning of injury to persons with a safety alert symbol may also include a warning relating to property damage.

Qualified personnel

The product/system described in this documentation may only be operated by **personnel qualified** for the specific task in accordance with the relevant documentation for the specific task, in particular its warning notices and safety instructions. Qualified personnel are those who, based on their training and experience, are capable of identifying risks and avoiding potential hazards when working with these products/systems.

Proper Use of Siemens Products

Note the following:

 WARNING
Siemens products are only permitted to be used for the applications listed in the catalog and in the associated technical documentation. If third-party products and components are used, then they must be recommended or approved by Siemens. These products can only function correctly and safely if they are transported, stored, set up, mounted, installed, commissioned, operated and maintained correctly. The permissible ambient conditions must be adhered to. Notes in the associated documentation must be observed.

Trademarks

All names identified with ® are registered trademarks of Siemens AG. Any other names used in this publication may be trademarks whose use by third parties for their own purposes could violate the rights of the owner.

Disclaimer of liability

We have checked the contents of this publication for consistency with the hardware and software described. Since variance cannot be precluded entirely, we cannot guarantee full consistency. The information given in this document is reviewed at regular intervals and any corrections that might be necessary are made in the subsequent editions.

Contents

1	Fundamental safety instructions	1-13
1.1	General safety instructions	1-14
1.2	Industrial security	1-15
2	Parameters	2-17
2.1	Introduction to Parameters	2-18
2.2	List of Parameters	2-24
2.3	Command and Drive Data Sets – Overview	2-161
2.3.1	Command Data Sets (CDS)	2-161
2.3.2	Drive Data Sets (DDS)	2-162
2.4	Connector/Binector (BICO)-Parameters	2-166
2.4.1	Binector Input Parameters	2-166
2.4.2	Connector Input Parameters	2-167
2.4.3	Binector Output Parameters	2-167
2.4.4	Connector Output Parameters	2-168
2.4.5	Connector/Binector Output Parameters	2-169
2.5	Quick commissioning (p0010 = 1)	2-170
3	Function diagrams	3-173
3.1	Contents: function diagrams	3-174
3.2	Symbols in function diagrams	3-176
3.3	Overview	3-178
3.4	External Interfaces	3-181
3.5	Internal Setpoint Source	3-186
3.6	Technology Functions	3-193
3.7	Free Function Blocks	3-204
3.8	Setpoint Channel	3-207
3.9	V/f Control	3-212
3.10	Display values	3-214
4	Faults and Alarms	4-217
4.1	Faults and Alarms – Overview	4-218
4.2	List of Faults and Alarms	4-219

A ASCII-Table A-233

B List of Abbreviations B-235

C Index C-239

Fundamental safety instructions

1

Contents

1.1	General safety instructions	1-14
1.2	Industrial security	1-15

1.1 General safety instructions

 WARNING
Danger to life if the safety instructions and residual risks are not observed
If the safety instructions and residual risks in the associated hardware documentation are not observed, accidents involving severe injuries or death can occur.
<ul style="list-style-type: none">• Observe the safety instructions given in the hardware documentation.• Consider the residual risks for the risk evaluation.

 WARNING
Danger to life or malfunctions of the machine as a result of incorrect or changed parameterization
As a result of incorrect or changed parameterization, machines can malfunction, which in turn can lead to injuries or death.
<ul style="list-style-type: none">• Protect the parameterization (parameter assignments) against unauthorized access.• Respond to possible malfunctions by applying suitable measures (e.g. EMERGENCY STOP or EMERGENCY OFF).

1.2 Industrial security

Note

Industrial security

Siemens provides products and solutions with industrial security functions that support the secure operation of plants, systems, machines and networks.

In order to protect plants, systems, machines and networks against cyber threats, it is necessary to implement – and continuously maintain – a holistic, state-of-the-art industrial security concept. Siemens products and solutions only represent one component of such a concept.

The customer is responsible for preventing unauthorized access to its plants, systems, machines and networks. Systems, machines and components should only be connected to the enterprise network or the internet if and to the extent necessary and with appropriate security measures (e.g. use of firewalls and network segmentation) in place.

Additionally, Siemens' guidance on appropriate security measures should be taken into account. For more information about industrial security, please visit:

Industrial security (<http://www.siemens.com/industrialsecurity>).

Siemens' products and solutions undergo continuous development to make them more secure. Siemens strongly recommends to apply product updates as soon as available and to always use the latest product versions. Use of product versions that are no longer supported, and failure to apply latest updates may increase customer's exposure to cyber threats.

To stay informed about product updates, subscribe to the Siemens Industrial Security RSS Feed at:

Industrial security (<http://www.siemens.com/industrialsecurity>).



WARNING

Danger to life as a result of unsafe operating states resulting from software manipulation

Software manipulations (e.g. viruses, trojans, malware or worms) can cause unsafe operating states in your system that may lead to death, serious injury, and property damage.

- Keep the software up to date.
- Incorporate the automation and drive components into a holistic, state-of-the-art industrial security concept for the installation or machine.
- Make sure that you include all installed products into the holistic industrial security concept.
- Protect files stored on exchangeable storage media from malicious software by with suitable protection measures, e.g. virus scanners.

Parameters

2

Contents

2.1	Introduction to Parameters	2-18
2.2	List of Parameters	2-24
2.3	Command and Drive Data Sets – Overview	2-161
2.4	Connector/Binector (BICO)-Parameters	2-166
2.5	Quick commissioning (p0010 = 1)	2-170

2.1 Introduction to Parameters

The layout of the parameter description is as follows.

	↙ BICO (if exist)		
r0027		CO: Act. output current / Act. output cur	
		Access level: 2	Calculated: -
		Unit: [A]	Scaling: p2002
			Data type: FloatingPoint32
			Data set: -

Fig. 2-1 Read-only parameter

	↙ Index	↙ BICO (if exist)		
p0701[0...2]			Function of digital input 0 / Function of DI0	
			Access level: 2	Calculated: -
			Can be changed: T	Scaling: -
			Min	Max
			0	99
				Factory setting
				0

Fig. 2-2 Write parameter

Parameter number

Indicates the relevant parameter number. The numbers used are 4-digit numbers in the range 0000 to 9999. Numbers prefixed with an “r” indicate that the parameter is a “read-only” parameter, which displays a particular value but cannot be changed directly by specifying a different value via this parameter number.

All other parameters are prefixed with a “p”. The values of these parameters can be changed directly in the range indicated by the “Min” and “Max” settings in the header. If these values have a physical unit, it is shown in brackets.

[index] indicates that the parameter is an indexed parameter and specifies the range of indices available. If the Index is [0...2] and the meaning is not listed then see “Data Set”.

.0...15 indicates that the parameter has several bits, which can be evaluated or connected individually.

Parameter text (Long name/Short name)

Indicates the name of the relevant parameter.

Certain parameter names include the following abbreviated prefixes: BI, BO, CI, CO and CO/BO followed by a colon.

These abbreviations have the following meanings:

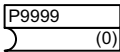
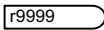
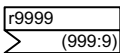
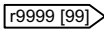
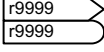
BI	=		Binector input, i.e. parameter selects the source of a binary signal
BO	=		Binector output, i.e. parameter connects as a binary signal
CI	=		Connector input, i.e. parameter selects the source of an analog signal
CO	=		Connector output, i.e. parameter connects as an analog signal
CO/BO	=		Connector/Binector output, i.e. parameter connects as an analog signal and/or as a binary signal

To make use of BICO you will need access to the full parameter list. At this level many new parameter settings are possible, including BICO functionality. BICO functionality is a different, more flexible way of setting and combining input and output functions. It can be used in most cases in conjunction with the simple, access level 2 settings.

The BICO system allows complex functions to be programmed. Boolean and mathematical relationships can be set up between inputs (digital, analog, serial etc.) and outputs (inverter current, frequency, analog output, relays, etc.).

At BI and CI parameters the parameter number is specified under Factory setting with which this parameter is connected. In this case the Min and Max values have dashes.

Access level (refers only to access via STARTER)

Indicates the level of user access. There are four access levels: Standard, Extended, Expert and Service. For the parameters of all variants there is only one freely accessible access level effective. The parameters with the declaration "Access level 1" to "Access level 3" belong to them. Parameters with access level 4 are service parameters and password protected.

Data type

The data types available are shown in the table below.

Table 2-1 Available data types

Notation	Meaning
Unsigned8 (U8)	8-bit unsigned
Unsigned16 (U16)	16-bit unsigned
Unsigned32 (U32)	32-bit unsigned
Integer16 (I16)	16-bit integer
Integer32 (I32)	32-bit integer
FloatingPoint32 (Float)	32-bit floating point number

The information of the data types for binector and connector inputs can be composed of two specifications (discreated by a slash):

- First specification: data type of the parameter
- Second specification: data type of the signal source preferably to be connected (binector or connector output)

Depending on the data type of the BICO input parameter (signal sink) and BICO output parameter (signal source) the following combinations are possible when creating BICO interconnections:

Table 2-2 Possible combinations of BICO interconnections

BICO output parameter	BICO input parameter			
	CI parameter			BI parameter
	Unsigned32 / Integer16	Unsigned32 / Integer32	Unsigned32 / FloatingPoint32	Unsigned32 / Binary
CO: Unsigned8	x	x	–	–
CO: Unsigned16	x	x	–	–
CO: Unsigned32	x	x	–	–
CO: Integer16	x	x	r2050	–
CO: Integer32	x	x	–	–
CO: FloatingPoint32	x	x	x	–
BO: Unsigned8	–	–	–	x
BO: Unsigned16	–	–	–	x
BO: Unsigned32	–	–	–	x
BO: Integer16	–	–	–	x
BO: Integer32	–	–	–	x
BO: FloatingPoint32	–	–	–	–
Legend:	x: BICO interconnection permitted –: BICO interconnection not permitted			

Scaling

Specification of the reference quantity with which the signal value will be converted automatically.

Reference quantities, corresponding to 100 %, are required for the statement of physical units as percentages. These reference quantities are entered in parameters p2000 ... p2004.

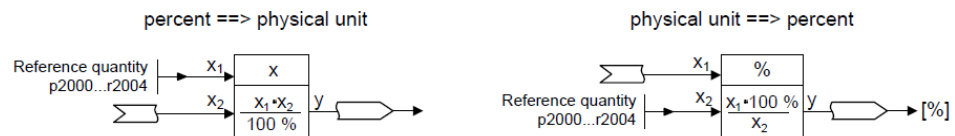

In addition to p2000 ... p2004 the following normalizations are used:

- TEMP 100 °C = 100 %
- PERCENT 1.0 = 100 %
- 4000H 4000 hex = 100 %

Calculated

Specifies whether the parameter is influenced by automatic calculations.

p0340 defines the following calculations:

- p0340 = 1 contains the calculations of p0340 = 2, 3, 4.
- p0340 = 2 calculates the motor parameters (p0350 ... p0360, p0625).
- p0340 = 3 contains the calculations of p0340 = 4.
- p0340 = 4 only calculates the controller parameters.

Note:

For p3900 > 0, also p0340 = 1 is automatically called.

After p1900 = 2, p0340 = 3 is automatically called.

These a reference to p0340 stands behind "Calculated", parameters are dependent from the frame size. In this case the values under "Factory setting" do not correspond to the actual values since these are found out during the commissioning. This also applies to the motor parameters.

Data Set

Parameters which are dependent on a data set are identified as follows:

- CDS (Command Data Set)
- DDS (Drive Data Set)

They are always indexed with [0...2].

For **CDS** is valid:

[0] = Command Data Set 0

[1] = Command Data Set 1

[2] = Command Data Set 2

For **DDS** is valid:

[0] = Drive Data Set 0

[1] = Drive Data Set 1

[2] = Drive Data Set 2

Can be changed

Inverter state in which the parameter is changeable. Three states are possible:

- Commissioning C or C(1)
- Run U
- Ready to runt T

This indicates when the parameter can be changed. One, two or all three states may be specified. If all three states are specified, this means that it is possible to change this parameter setting in all three inverter states. C(1) shows, that the parameter is only changeable when p0010 = 1 (Quick commissioning).

Unit

Indicates the unit of measure applicable to the parameter values.

Min

Indicates the minimum value to which the parameter can be set.

Max

Indicates the maximum value to which the parameter can be set.

Factory setting

Indicates the default value, i.e. the value which applies if the user does not specify a particular value for the parameter.

Description

Explanation of the function of a parameter.

Values

Lists the possible values of a parameter.

Index

The name and meaning of each individual index is specified for indexed parameters, except indexed parameters which belong to a data set (see "Data Set").

Bit field

For parameters with bit fields, the following information is provided about each bit:

- Bit number and signal name
- Meaning with signal states 0 and 1
- Function diagram (optional). The signal is shown on this function diagram.

Dependency

Conditions which need to be fulfilled in connection with this parameter. Also includes special effects which can occur between this parameter and others.

2.2 List of Parameters

Product: G110D, Version: 3700000, Language: eng
Objects: CUG110D ASI, PMG110D

r0000	Drive display / Drive display		
	Access level: 1	Calculated: -	Data type: Unsigned16
	Unit: -	Scaling: -	Data set: -
Description:	Displays the user selected output. This value is defined in P0005.		
r0002	Drive state / Drive state		
	Access level: 2	Calculated: -	Data type: Unsigned16
	Unit: -	Scaling: -	Data set: -
Description:	Displays actual drive state.		
Value:	0: Commissioning mode (P0010 != 0) 1: Drive ready 2: Drive fault active 3: Drive starting (DC-link precharging) 4: Drive running 5: Stopping (ramping down) 6: Drive inhibited		
Dependency:	State 3 visible only while precharging DC link. It is only visible when an externally powered control unit is fitted.		
p0003	User access level / User access level		
	Access level: 1	Calculated: -	Data type: Unsigned16
	Can be changed: U, T	Scaling: -	Data set: -
	Min	Max	Factory setting
	0	4	1
Description:	Defines user access level to parameter sets. The default setting (standard) is sufficient for most simple applications.		
Value:	0: User defined parameter list - see P0013 for details on use 1: Standard: Allows access into most frequently used parameters. 2: Extended: Allows extended access e.g. to inverter I/O functions 3: Expert: For expert use only. 4: Service: Only for use by authorized service, password protected		
Note:	Only valid for control units with OP.		
p0004	Parameter filter / Parameter filter		
	Access level: 1	Calculated: -	Data type: Unsigned16
	Can be changed: U, T	Scaling: -	Data set: -
	Min	Max	Factory setting
	0	22	0
Description:	Filters parameters according to functionality to enable a more focussed approach to commissioning.		
Value:	0: All parameters 2: Inverter 3: Motor 5: Technol. application / units 7: Commands, binary I/O 8: AI 10: Setpoint channel / RFG 12: Drive features 13: Motor control 19: Motor identification 20: Communication 21: Warnings / faults / monitoring 22: Technology controller		

p0010	Commissioning parameter / Commissioning par.		
	Access level: 1	Calculated: -	Data type: Unsigned16
	Can be changed: T	Scaling: -	Data set: -
	Min 0	Max 30	Factory setting 0
Description:	Filters parameters so that only those related to a particular functional group are selected.		
Value:	0: Ready 1: Quick commissioning 2: Inverter 29: Download 30: Factory setting		
Dependency:	Reset to 0 for inverter to run. P0003 (user access level) also determines access to parameters.		
Note:	<ul style="list-style-type: none"> • P0010 = 1 The inverter can be commissioned very quickly and easily by setting P0010 = 1. After that only the important parameters (e.g.: P0304, P0305, etc.) are visible. The value of these parameters must be entered one after the other. The end of quick commissioning and the start of internal calculation will be done by setting P3900 = 1 - 3. Afterwards parameter P0010 and P3900 will be reset to zero automatically. • P0010 = 2 For service purposes only. • P0010 = 29 To transfer a parameter file via PC tool (e.g.: STARTER) parameter P0010 will be set to 29 by the PC tool. When download has been finished PC tool resets parameter P0010 to zero. • P0010 = 30 When resetting the parameters of inverter P0010 must be set to 30. Resetting of the parameters will be started by setting parameter P0970 = 1. The inverter will automatically reset all its parameters to their default settings. This can prove beneficial if you experience problems during parameter setup and wish to start again. Duration of factory setting will take about 60 s. 		
p0011	Lock for user defined parameter / LockUserDefinedPar		
	Access level: 3	Calculated: -	Data type: Unsigned16
	Can be changed: C, U, T	Scaling: -	Data set: -
	Min 0	Max 65535	Factory setting 0
Note:	See parameter P0013 (user defined parameter)		
p0012	Key for user defined parameter / Key UserDefinedPar		
	Access level: 3	Calculated: -	Data type: Unsigned16
	Can be changed: C, U, T	Scaling: -	Data set: -
	Min 0	Max 65535	Factory setting 0
Note:	See parameter P0013 (user defined parameter).		

p0013[0...19]	User defined parameter / User-defined par		
	Access level: 3	Calculated: -	Data type: Unsigned16
	Can be changed: C, U, T	Scaling: -	Data set: -
	Min 0	Max 65535	Factory setting [0...16] 0 [17] 3 [18] 10 [19] 12
Description:	<p>Defines a limited set of parameters to which the end user will have access.</p> <p>Instructions for use:</p> <ol style="list-style-type: none"> Set P0003 = 3 (expert user). Go to P0013 indices 0 to 16 (user list) Enter into P0013 index 0 to 16 the parameters required to be visible in the user-defined list. The following values are fixed and cannot be changed: <ul style="list-style-type: none"> P0013 index 17 = 3 (user access level) P0013 index 18 = 10 (commissioning parameter filter) P0013 index 19 = 12 (key for user defined parameter) Set P0003 = 0 to activate the user defined parameter. 		
Index:	<p>[0] = 1st user parameter [1] = 2nd user parameter [2] = 3rd user parameter [3] = 4th user parameter [4] = 5th user parameter [5] = 6th user parameter [6] = 7th user parameter [7] = 8th user parameter [8] = 9th user parameter [9] = 10th user parameter [10] = 11th user parameter [11] = 12th user parameter [12] = 13th user parameter [13] = 14th user parameter [14] = 15th user parameter [15] = 16th user parameter [16] = 17th user parameter [17] = 18th user parameter [18] = 19th user parameter [19] = 20th user parameter</p>		
Dependency:	<p>First, set P0011 ("lock") to a different value then P0012 ("key") to prevent changes to user-defined parameter. Then, set P0003 to 0 to activate the user-defined list.</p> <p>When locked and the user-defined parameter is activated, the only way to exit the user-defined parameter (and view other parameters) is to set P0012 ("key") to the value in P0011 ("lock").</p>		
Note:	The default values of P0011 ("lock") and P0012 ("key") are the same.		

p0014[0...2]	Store mode / Store mode		
	Access level: 3	Calculated: -	Data type: Unsigned16
	Can be changed: U, T	Scaling: -	Data set: -
	Min 0	Max 1	Factory setting 0
Description:	<p>Sets the store mode for parameters.</p> <p>The store mode can be configured for all interfaces listed under "Index".</p>		
Value:	<p>0: Volatile (RAM) 1: Nonvolatile (EEPROM)</p>		
Index:	<p>[0] = reserved [1] = USS on RS232 [2] = Fieldbus</p>		

Note: An independent store request may be part of the serial communications (e.g. PKE bits 15-12 of USS protocol), set by a PLC or PC tools like STARTER. See the table below for an influence on the settings of P0014.

Value of p0014[x]	Store request via USS/Fieldbus	Result
RAM	EEPROM	EEPROM
EEPROM	EEPROM	EEPROM
RAM	RAM	RAM
EEPROM	RAM	EEPROM

1. P0014 itself will always be stored in the EEPROM.
2. P0014 will not be changed by performing a factory reset (P0010 = 30 and P0970 = 1).
3. P0014 can be transferred during a download (P0010 = 29).

When transferring parameter p0014, the inverter uses its processor to carry-out internal calculations. Communications - both via USS as well as via the Fieldbus - are interrupted for the time that it takes to make these calculations. This can result in the following error messages at the connected SIMATIC S7 control (communications via fieldbus):

- Parameter fault 30
- Drive fault 70
- Drive fault 75

When using STARTER (USS) to commission the drive system, data cannot be entered while these calculations are being made.

The faults can be acknowledged as soon as the calculations have been completed in the frequency inverter. These calculations can take up to one minute to complete.

r0018	Firmware version / Firmware version		
	Access level: 1	Calculated: -	Data type: FloatingPoint32
	Unit: -	Scaling: -	Data set: -
Description:	Displays version number of installed firmware.		

r0019.2...9	CO/BO: OP control word / OP CtrlWd		
	Access level: 3	Calculated: -	Data type: Unsigned16
	Unit: -	Scaling: -	Data set: -
Description:	Displays status of operator panel commands. The settings below are used as the "source" codes for keypad control when connecting to BICO input parameters.		
Bit field:	Bit	Signal name	1 signal 0 signal FP
	02	Remote	Yes No -
	03	Local	Yes No -
	04	Switch Off	Yes No -
	05	Quickstop Override	Yes No -
	06	JOG Continuous	Yes No -
	08	Jog Right	Yes No -
	09	Jog Left	Yes No -
Note:	When BICO technology is used to allocate functions to panel buttons, this parameter displays the actual status of the relevant command.		

r0020	CO: Freq. setpoint before RFG / Setp before RFG		
	Access level: 3	Calculated: -	Data type: FloatingPoint32
	Unit: [Hz]	Scaling: -	Data set: -
Description:	Displays actual frequency setpoint (input of ramp function generator). This value is available filtered (r0020) and unfiltered (r1119). The actual frequency setpoint after RFG is displayed in r1170.		

r0021	CO: Act. filtered frequency / Act. filt. freq.		
	Access level: 2	Calculated: -	Data type: FloatingPoint32
	Unit: [Hz]	Scaling: -	Data set: -
Description:	Displays actual inverter output frequency (r0024) excluding slip compensation (and resonance damping, frequency limitation in V/f mode).		
r0022	Act. filtered rotor speed / Act fil rotorspeed		
	Access level: 3	Calculated: -	Data type: FloatingPoint32
	Unit: [RPM]	Scaling: -	Data set: -
Description:	Displays calculated rotor speed based on r0021 (filtered output frequency [Hz] x 120 / number of poles). The value is updated every 128 ms.		
Note:	This calculation makes no allowance for load-dependent slip.		
r0024	CO: Act. filt. output frequency / Act. outp. freq		
	Access level: 3	Calculated: -	Data type: FloatingPoint32
	Unit: [Hz]	Scaling: -	Data set: -
Description:	Displays actual filtered output frequency (slip compensation, resonance damping and frequency limitation are included). See also r0021.		
r0025	CO: Act. output voltage / Act.outp. volt		
	Access level: 2	Calculated: -	Data type: FloatingPoint32
	Unit: [V]	Scaling: -	Data set: -
Description:	Displays filtered [rms] voltage applied to motor. This value is available filtered (r0025) and unfiltered (r0072).		
r0026[0]	CO: Act. filtered DC-link volt. / Act. fil. Vdc		
	Access level: 2	Calculated: -	Data type: FloatingPoint32
	Unit: [V]	Scaling: -	Data set: -
Description:	Displays filtered DC-link voltage. This value is available filtered (r0026) and unfiltered (r0070).		
Index:	[0] = Compensation DC voltage Channel		
r0027	CO: Act. output current / Act. outp. cur		
	Access level: 2	Calculated: -	Data type: FloatingPoint32
	Unit: [A]	Scaling: p2002	Data set: -
Description:	Displays rms value of motor current [A]. This value is available filtered (r0027) and unfiltered (r0068).		
r0031	CO: Act. filtered torque / Act fil torque		
	Access level: 2	Calculated: -	Data type: FloatingPoint32
	Unit: [Nm]	Scaling: -	Data set: -
Description:	Displays electrical torque. This value is available filtered (r0031) and unfiltered (r0080).		
Note:	The electrical torque is not the same as the mechanical torque, which can be measured on the shaft. Due to windage and friction a part of the electrical torque is lost in the motor.		
r0032	CO: Act. filtered power / Act fil. power		
	Access level: 2	Calculated: -	Data type: FloatingPoint32
	Unit: -	Scaling: r2004	Data set: -
Description:	Displays (mechanical) shaft power. Value is displayed in [kW] or [hp] depending on setting for P0100 (operation for Europe / North America). $P_{mech} = 2 * \pi * f * M \rightarrow$ $r0032[kW] = (2 * \pi / 1000) * (r0022 / 60)[1/min] * r0031[Nm]$ $r0032[hp] = r0032[kW] / 0.75$		

r0035[0...2]	CO: Act. motor temperature / Act. mot.temp.		
	Access level: 2	Calculated: -	Data type: FloatingPoint32
	Unit: [°C]	Scaling: -	Data set: DDS
Description:	Displays measured motor temperature.		
r0036	CO: Inverter overload utilization / Invert ovl util		
	Access level: 4	Calculated: -	Data type: FloatingPoint32
	Unit: [%]	Scaling: PERCENT	Data set: -
Description:	<p>Displays inverter overload utilization calculated via the I2t model.</p> <p>The actual I2t value relative to the max. possible I2t value supplies utilization in [%].</p> <p>If the current exceeds the threshold for P0294 (inverter I2t overload warning), warning A0505 (inverter I2t) is generated and the output current of the inverter reduced via P0290 (inverter overload reaction).</p> <p>If 100 % utilization is exceeded, fault F0005 (inverter I2t) is tripped.</p>		
Dependency:	<p>r0036 > 0:</p> <p>If the nominal current (see r0207) of the inverter is exceed, utilization will be displayed, otherwise, 0 % utilization is displayed.</p>		
r0037[0...2]	CO: Inverter temperature [°C] / Inverter temp.		
	Access level: 3	Calculated: -	Data type: FloatingPoint32
	Unit: [°C]	Scaling: -	Data set: -
Description:	Displays measured heatsink temperature and calculated junction temperature of IGBTs based on thermal model.		
Index:	<p>[0] = Measured heat sink temperature</p> <p>[1] = Total Chip Junction Temperature</p> <p>[2] = Control board temperature</p>		
Note:	The values are updated every 128 ms.		
r0038	CO: Fil. power factor / Fil.power fact		
	Access level: 3	Calculated: -	Data type: FloatingPoint32
	Unit: -	Scaling: -	Data set: -
Description:	Displays the filtered power factor.		
r0039	CO: Energy consumpt. meter [kWh] / Energy meter		
	Access level: 2	Calculated: -	Data type: FloatingPoint32
	Unit: [kWh]	Scaling: -	Data set: -
Description:	Displays electrical energy used by inverter since display was last reset (see P0040 - reset energy consumption meter).		
Dependency:	Value is reset when P0040 = 1 (reset energy consumption meter).		
p0040	Reset energy consumption meter / Reset energy meter		
	Access level: 2	Calculated: -	Data type: Unsigned16
	Can be changed: T	Scaling: -	Data set: -
	Min	Max	Factory setting
	0	1	0
Description:	Resets value of parameter r0039 (energy consumption meter) to zero.		
Value:	<p>0: No reset</p> <p>1: Reset r0039 to 0</p>		

r0050	CO/BO: Active Command Dataset / Active CDS		
	Access level: 2	Calculated: -	Data type: Unsigned16
	Unit: -	Scaling: -	Data set: -
Description:	Displays currently active Command Dataset (CDS).		
Value:	0: Command Dataset 0 (CDS) 1: Command Dataset 1 (CDS) 2: Command Dataset 2 (CDS)		
Note:	See parameter P0810.		

r0051[0...1]	CO: Active Drive Dataset (DDS) / Active DDS		
	Access level: 2	Calculated: -	Data type: Unsigned16
	Unit: -	Scaling: -	Data set: -
Description:	Displays currently selected and active Drive Dataset (DDS).		
Value:	0: Drive Dataset 0 (DDS0) 1: Drive Dataset 1 (DDS1) 2: Drive Dataset 2 (DDS2)		
Index:	[0] = Selected Drive Dataset [1] = Active Drive Dataset		
Note:	See parameter P0820.		

r0052.0...15	CO/BO: Act. status word 1 / Act StatWd1		
	Access level: 2	Calculated: -	Data type: Unsigned16
	Unit: -	Scaling: -	Data set: -
Description:	Displays first active status word of inverter (bit format) and can be used to diagnose inverter status.		
Bit field:	Bit	Signal name	1 signal 0 signal FP
	00	Drive ready	Yes No -
	01	Drive ready to run	Yes No -
	02	Drive running	Yes No -
	03	Drive fault active	Yes No -
	04	OFF2 active	No Yes -
	05	OFF3 active	No Yes -
	06	ON inhibit active	Yes No -
	07	Drive warning active	Yes No -
	08	Deviation setpoint / act. value	No Yes -
	09	PZD control	Yes No -
	10	f_act >= P1082 (f_max)	Yes No -
	11	Warning: Motor current/torque limit	No Yes -
	12	Brake open	Yes No -
	13	Motor overload	No Yes -
	14	Motor runs right	Yes No -
	15	Inverter overload	No Yes -
Note:	See parameters r2197 and r2198.		

r0053.0...15	CO/BO: Act. status word 2 / Act StatWd2		
	Access level: 2	Calculated: -	Data type: Unsigned16
	Unit: -	Scaling: -	Data set: -
Description:	Displays second status word of inverter (in bit format).		
Bit field:	Bit	Signal name	1 signal 0 signal FP
	00	DC brake active	Yes No -
	01	f_act > P2167 (f_off)	Yes No -
	02	f_act > P1080 (f_min)	Yes No -
	03	Act. current r0068 >= P2170	Yes No -
	04	f_act > P2155 (f_1)	Yes No -
	05	f_act <= P2155 (f_1)	Yes No -
	06	f_act >= setpoint (f_set)	Yes No -

07	Act. unfilt. Vdc < P2172	Yes	No	-
08	Act. unfilt. Vdc > P2172	Yes	No	-
09	Ramping finished	Yes	No	-
10	PID output r2294 == P2292 (PID_min)	Yes	No	-
11	PID output r2294 == P2291 (PID_max)	Yes	No	-
13	Drive ready to run from PLC	Yes	No	-
14	Download Dataset 0 from OP	Yes	No	-
15	Download Dataset 1 from OP	Yes	No	-

Notice: r0053 Bit00 "DC brake active" ==> see parameter P1233

Note: See parameters r2197 and r2198.

r0054.0...15 CO/BO: Act. control word 1 / Act CtrlWd1

Access level: 3 **Calculated:** - **Data type:** Unsigned16
Unit: - **Scaling:** - **Data set:** -

Description: Displays first control word of inverter (in bit format) and can be used to diagnose which commands are active.

Bit field:	Bit	Signal name	1 signal	0 signal	FP
	00	ON/OFF1	Yes	No	-
	01	OFF2: Electrical stop	No	Yes	-
	02	OFF3: Fast stop	No	Yes	-
	03	Pulse enable	Yes	No	-
	04	RFG enable	Yes	No	-
	05	RFG start	Yes	No	-
	06	Setpoint enable	Yes	No	-
	07	Fault acknowledge	Yes	No	-
	08	JOG right	Yes	No	-
	09	JOG left	Yes	No	-
	10	Control from PLC	Yes	No	-
	11	Reverse (setpoint inversion)	Yes	No	-
	13	Motor potentiometer MOP up	Yes	No	-
	14	Motor potentiometer MOP down	Yes	No	-
	15	CDS Bit 0 (Hand/Auto)	Yes	No	-

Notice: r0054 is identical to r2032 if USS is selected as command source via P0700 or P0719.

r0055.0...15 CO/BO: Act. control word 2 / Act CtrlWd2

Access level: 3 **Calculated:** - **Data type:** Unsigned16
Unit: - **Scaling:** - **Data set:** -

Description: Displays additional control word of inverter (in bit format) and can be used to diagnose which commands are active.

Bit field:	Bit	Signal name	1 signal	0 signal	FP
	00	Fixed frequency Bit 0	Yes	No	-
	01	Fixed frequency Bit 1	Yes	No	-
	02	Fixed frequency Bit 2	Yes	No	-
	03	Fixed frequency Bit 3	Yes	No	-
	04	Drive Dataset (DDS) Bit 0	Yes	No	-
	05	Drive Dataset (DDS) Bit 1	Yes	No	-
	06	Quick Stop disable	Yes	No	-
	08	Enable PID	Yes	No	-
	09	Enable DC brake	Yes	No	-
	13	External fault 1	No	Yes	-
	15	Command Dataset (CDS) Bit 1	Yes	No	-

Notice: r0055 is identical to r2033 if USS is selected as command source via P0700 or P0719.

r0056.0...14	CO/BO: Status of motor control / Stat MotCtrl		
	Access level: 3	Calculated: -	Data type: Unsigned16
	Unit: -	Scaling: -	Data set: -
Description:	Displays status of motor control (in bit format), which can be used to diagnose inverter status.		
Bit field:	Bit	Signal name	1 signal 0 signal FP
	00	Init. control finished	Yes No -
	01	Motor demagnetizing finished	Yes No -
	02	Pulses enabled	Yes No -
	03	Voltage soft start select	Yes No -
	04	Motor excitation finished	Yes No -
	05	Starting boost active	Yes No -
	06	Acceleration boost active	Yes No -
	07	Frequency is negative	Yes No -
	08	Field weakening active	Yes No -
	09	Volts setpoint limited	Yes No -
	10	Slip frequency limited	Yes No -
	11	f_out > f_max Freq. limited	Yes No -
	12	Phase reversal selected	Yes No -
	13	Imax controller active/torque limit reached	Yes No -
	14	Vdc-max controller active	Yes No -
Notice:	The I-max controller (r0056 Bit13) will be activated when the actual output current (r0027) exceeds the current limit in r0067.		
r0066	CO: Act. output frequency / Act. outp freq		
	Access level: 3	Calculated: -	Data type: FloatingPoint32
	Unit: [Hz]	Scaling: -	Data set: -
Description:	Displays actual output frequency in Hz. This value is available filtered (r0024) and unfiltered (r0066).		
Note:	The output frequency is limited by the values entered in P1080 (min. frequency) and P1082 (max. frequency).		
r0067	CO: Act. output current limit / Outp cur limit		
	Access level: 3	Calculated: -	Data type: FloatingPoint32
	Unit: [A]	Scaling: p2002	Data set: -
Description:	Displays valid maximum output current of inverter. Parameter r0067 is influenced/determined by the following factors:		
	<ul style="list-style-type: none"> • Rated motor current P0305 • Motor overload factor P0640 • Motor protection in dependency of P0610 • r0067 is less than or equal to maximum inverter current r0209 • Inverter protection in dependency of P0290 		
Note:	A reduction of r0067 may indicate an inverter overload or a motor overload.		
r0068	CO: Output current / Output current		
	Access level: 3	Calculated: -	Data type: FloatingPoint32
	Unit: [A]	Scaling: p2002	Data set: -
Description:	Displays unfiltered [rms] value of motor current [A]. This value is available filtered (r0027) and unfiltered (r0068).		
Note:	Used for process control purposes (in contrast to r0027, which is filtered and is used to display the value through USS on RS232).		

r0069[0...5]	CO: Act. phase currents / Act. phase cur		
	Access level: 4	Calculated: -	Data type: FloatingPoint32
	Unit: [A]	Scaling: p2002	Data set: -
Description:	Displays measured phase currents.		
Index:	[0] = U_phase [1] = V_phase [2] = W_phase [3] = Offset U_phase [4] = Offset V_phase [5] = Offset W_phase		
r0070	CO: Act. DC-link voltage / Act. Vdc		
	Access level: 3	Calculated: -	Data type: FloatingPoint32
	Unit: [V]	Scaling: -	Data set: -
Description:	Displays DC-link voltage. This value is available filtered (r0026) and unfiltered (r0070).		
Note:	Used for process control purposes (in contrast to r0026 (actual DC-link voltage), which is filtered).		
r0071	CO: Max. output voltage / Max. outp.volt		
	Access level: 3	Calculated: -	Data type: FloatingPoint32
	Unit: [V]	Scaling: -	Data set: -
Description:	Displays maximum output voltage.		
Dependency:	Actual maximum output voltage depends on the actual input supply voltage.		
r0072	CO: Act. output voltage / Act. outp.volt		
	Access level: 3	Calculated: -	Data type: FloatingPoint32
	Unit: [V]	Scaling: -	Data set: -
Description:	Displays output voltage. This value is available filtered (r0025) and unfiltered (r0072).		
r0074	CO: Act. modulation / Act modulation		
	Access level: 4	Calculated: -	Data type: FloatingPoint32
	Unit: [%]	Scaling: PERCENT	Data set: -
Description:	Displays actual modulation index. The modulation index is defined as ratio between the magnitude of the fundamental component in the inverter phase output voltage and half of the DC-link voltage.		
r0080	CO: Act. torque / Act. torque		
	Access level: 4	Calculated: -	Data type: FloatingPoint32
	Unit: [Nm]	Scaling: -	Data set: -
Description:	Displays actual torque. This value is available filtered (r0031) and unfiltered (r0080).		
r0084	CO: Act. air gap flux / Air gap flux		
	Access level: 4	Calculated: -	Data type: FloatingPoint32
	Unit: [%]	Scaling: PERCENT	Data set: -
Description:	Displays air gap flux in [%] relative to the rated motor flux.		
r0085	CO: Act. re-active current / Act.re-active cur		
	Access level: 3	Calculated: -	Data type: FloatingPoint32
	Unit: [A]	Scaling: p2002	Data set: -
Description:	Displays re-active (imaginary part) of motor current.		
Dependency:	Applies when V/f control is selected in P1300 (control mode); otherwise, the display shows the value zero.		

r0086	CO: Act. active current / Act.active cur		
	Access level: 3	Calculated: -	Data type: FloatingPoint32
	Unit: [A]	Scaling: p2002	Data set: -
Description:	Displays active (real part) of motor current.		
Dependency:	Applies when V/f control is selected in P1300 (control mode); otherwise, the display shows the value zero.		
r0087	CO: Act. power factor / Act.power fact		
	Access level: 3	Calculated: -	Data type: FloatingPoint32
	Unit: -	Scaling: -	Data set: -
Description:	Displays the actual power factor.		
r0094	CO: Transformation angle / Transf. angle		
	Access level: 3	Calculated: -	Data type: FloatingPoint32
	Unit: [°]	Scaling: 4000H	Data set: -
Description:	Displays the transformation angle from frequency.		
p0095[0...9]	CI: Display PZD signals / PZD signals		
	Access level: 3	Calculated: -	Data type: U32 / Integer16
	Can be changed: T	Scaling: 4000H	Data set: -
	Min	Max	Factory setting
	-	-	0
Description:	Selects source of display for PZD signals.		
Index:	[0] = 1st PZD signal [1] = 2nd PZD signal [2] = 3rd PZD signal [3] = 4th PZD signal [4] = 5th PZD signal [5] = 6th PZD signal [6] = 7th PZD signal [7] = 8th PZD signal [8] = 9th PZD signal [9] = 10th PZD signal		
r0096[0...9]	PZD signals / PZD signals		
	Access level: 3	Calculated: -	Data type: FloatingPoint32
	Unit: [%]	Scaling: -	Data set: -
Description:	Displays PZD signals in [%].		
Index:	[0] = 1st PZD signal [1] = 2nd PZD signal [2] = 3rd PZD signal [3] = 4th PZD signal [4] = 5th PZD signal [5] = 6th PZD signal [6] = 7th PZD signal [7] = 8th PZD signal [8] = 9th PZD signal [9] = 10th PZD signal		
Note:	r0096 = 100 % corresponds to 4000 hex.		

p0100	Europe / North America / Europe / Nth Amer.		
	Access level: 1	Calculated: -	Data type: Unsigned16
	Can be changed: C(1)	Scaling: -	Data set: -
	Min 0	Max 2	Factory setting 0
Description:	Determines whether power settings are expressed in [kW] or [hp] (e.g. Rated motor power P0307). The default settings for the rated motor frequency P0310 and maximum frequency P1082 are set automatically here, in addition to reference frequency P2000.		
Value:	0: Europe [kW], motor base frequency is 50 Hz 1: North America [hp], motor base frequency is 60 Hz 2: North America [kW], motor base frequency is 60 Hz		
Dependency:	Where: <ul style="list-style-type: none"> • Stop drive first (i.e. disable all pulses) before you change this parameter. • Parameter P0100 can only be changed with P0010 = 1 (Commissioning mode) via the respective interface (e.g. USS on RS232). • Changing P0100 resets all rated motor parameters as well as other parameters that depend on the rated motor parameters (see P0340 - calculation of motor parameters). 		
r0191[0...2]	Configuration Control Unit / Config CU		
	Access level: 3	Calculated: -	Data type: Unsigned32
	Unit: -	Scaling: -	Data set: -
Description:	Displays the actual HW-configuration (SZL vector) of the Control Unit.		
Index:	[0] = SZL Vector CU and PM combined [1] = SZL Vector CU [2] = SZL Vector PM		
p0199	Equipment system number / Equip. system no.		
	Access level: 2	Calculated: -	Data type: Unsigned16
	Can be changed: U, T	Scaling: -	Data set: -
	Min 0	Max 255	Factory setting 0
Description:	Equipment system number. This parameter has no operation effect (only for factory purposes).		
p0201[0...2]	Act. power module code number / Act.Pmod. code no		
	Access level: 3	Calculated: -	Data type: Unsigned16
	Can be changed: T	Scaling: -	Data set: -
	Min 0	Max 65535	Factory setting [0] 0 [1] 0 [2] 132
Description:	Identifies hardware variant.		
Index:	[0] = Powerstack code [1] = Functionality version - Last Digit of MLFB [2] = Last used PS Id		
Notice:	Parameter P0201 = 0 indicates that no power module has been identified.		

r0203	Act. inverter type / Act. inverter type			
	Access level: 3	Calculated: -	Data type: Unsigned16	
	Unit: -	Scaling: -	Data set: -	
Description:	Type number of actual inverter identified.			
Value:	0: No PS Data/Module 1: reserved 2: reserved 3: reserved 4: reserved 5: reserved 6: reserved 7: reserved 110: SINAMICS G110 111: SINAMICS IPM25 114: SINAMICS PM240 115: SINAMICS PM250 117: SINAMICS PM240 PX 125: SINAMICS ET200PRO 130: SINAMICS PM DCP 132: SINAMICS PM G110D			
r0204	Power module features / Pmodule features			
	Access level: 3	Calculated: -	Data type: Unsigned32	
	Unit: -	Scaling: -	Data set: -	
Description:	Displays hardware features of power module.			
Bit field:	Bit	Signal name	1 signal	0 signal
	00	DC input voltage	Yes	No
	01	RFI filter	Yes	No
	02	Active Line Module	Yes	No
	03	SLM	Yes	No
	04	BLM with thyristor	Yes	No
	05	BLM with Diode	Yes	No
	06	Water Cooled	Yes	No
	12	Safe Brake	Yes	No
	13	Safety Enabled	Yes	No
	14	Integrated Output Filter	Yes	No
Note:	Parameter r0204 = 0 indicates that no power module has been identified.			
p0205	Inverter application / Inverter appl.			
	Access level: 3	Calculated: -	Data type: Unsigned16	
	Can be changed: C(1)	Scaling: -	Data set: -	
	Min	Max	Factory setting	
	0	1	0	
Description:	Selects inverter application. The inverter and motor requirements are determined by the speed range and torque requirements of the load. Dependent on the frequency/torque characteristic of the application this parameter can be set to high overload (HO) or light overload (LO). <ul style="list-style-type: none"> • High overload (HO): HO is used if the application needs a high overload on the whole frequency range. Many loads can be considered to be high overloads. Typical high overloads are conveyors, compressors and positive displacement pumps. • Light overload (LO): LO is used if the application has a parabolic frequency/torque characteristic like many fans and pumps. Light overload offers the following possibilities with the same inverter: <ul style="list-style-type: none"> - Higher rated inverter current r0207 - Higher rated inverter power r0206 - Higher threshold for I2t protection 			

If P0205 is modified in quick commissioning it immediately calculates various motor parameters:

1. P0305 Rated motor current
2. P0307 Rated motor power
3. P0640 Motor overload factor

It is recommended to modify P0205 first. Afterwards motor parameter may be adapted.

Motor parameter will be overridden by changing this sequence.

Value:
0: High overload
1: Light overload

Notice: Use setting 1 (light overload) only for light-overload applications (e.g. pumps and fans).

If used for high-overload applications, I_{2t} warning will be produced too late, causing overheating in the motor.

Note: The parameter value is not reset by the factory setting (see P0970).

r0206 Rated inverter power [kW] / [hp] / Rated power[kW/hp]

Access level: 2 **Calculated:** - **Data type:** FloatingPoint32
Unit: - **Scaling:** - **Data set:** -

Description: Displays nominal rated motor power from inverter.

Dependency: Value is displayed in [kW] or [hp] depending on setting for P0100 (operation for Europe / North America).

r0207[0...2] Rated inverter current / Rated inverter cur

Access level: 2 **Calculated:** - **Data type:** FloatingPoint32
Unit: [A] **Scaling:** - **Data set:** -

Description: Displays rated inverter current.

Index:
[0] = Rated inverter current
[1] = Rated LO current
[2] = Rated HO current

Note: The rated light overload (LO) current r0207[1] and rated high overload (HO) current r0207[2] values correspond to suitable 4-pole Siemens standard motors (IEC) for the selected load cycle (see diagram).

The parameters r0207[1], r0207[2] are the default value of P0305 in association with the HO/LO application (load cycle).

If r0207[1] = r0207[2], then no differentiation is possible between HO/LO applications.

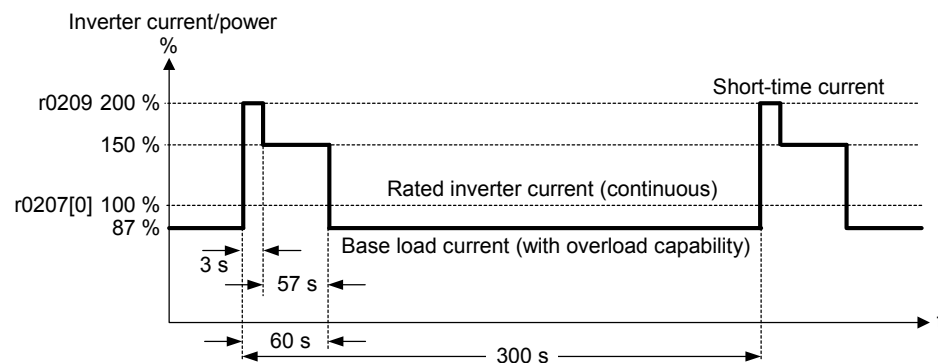

r0208 Rated inverter voltage / Rated voltage

Access level: 2 **Calculated:** - **Data type:** Unsigned32
Unit: [V] **Scaling:** - **Data set:** -

Description: Displays nominal AC supply voltage of inverter.

Note: r0208 = 230 : 200 - 240 V +/- 10 %

r0208 = 400 : 380 - 480 V +/- 10 %

r0208 = 575 : 500 - 600 V +/- 10 %

r0209	Maximum inverter current / Max. inverter cur		
	Access level: 2	Calculated: -	Data type: FloatingPoint32
	Unit: [A]	Scaling: -	Data set: -
Description:	Displays maximum output current of inverter.		
Dependency:	Parameter r0209 depends on the derating which is affected by pulse frequency P1800, ambient temperature and altitude. The data of deration is given in the Operating Instructions.		
p0210	Supply voltage / Supply voltage		
	Access level: 3	Calculated: -	Data type: Unsigned16
	Can be changed: T	Scaling: -	Data set: -
	Min 0 [V]	Max 1000 [V]	Factory setting 400 [V]
Description:	Parameter P0210 defines the supply voltage. Its default value depends upon the type of inverter. If P0210 does not correspond to the supply voltage, then it must be modified.		
Dependency:	Optimizes Vdc controller, which extends the ramp-down time if regenerative energy from motor would otherwise cause DC-link overvoltage trips. Reducing the value enables controller to cut in earlier and reduce the risk of overvoltage. Set P1254 ("Auto detect Vdc switch-on levels") = 0. Cut-in levels for Vdc-controller is derived directly from P0210 (supply voltage). <ul style="list-style-type: none"> Vdc_max switch-on level = $1.15 * \sqrt{2} * p0210$ Dynamic braking switch-on level = $1.13 * \sqrt{2} * p0210$ 		
Note:	If mains voltage is higher than value entered, automatic deactivation of the Vdc controller may occur to avoid acceleration of the motor. A warning will be issued in this case (A0910). Default value is depending on inverter type and its rating data.		
r0231[0...1]	Max. cable length / Max. cable length		
	Access level: 3	Calculated: -	Data type: Unsigned16
	Unit: [m]	Scaling: -	Data set: -
Description:	Indexed parameter to display maximum allowable cable length between inverter and motor.		
Index:	[0] = Max. allowed unscreened cable length [1] = Max. allowed screened cable length		
Notice:	For full EMC compliance, the screened cable must not exceed 25 m in length when an EMC filter is fitted.		
p0290	Inverter overload reaction / Overload reaction		
	Access level: 3	Calculated: -	Data type: Unsigned16
	Can be changed: T	Scaling: -	Data set: -
	Min 0	Max 3	Factory setting 2
Description:	Selects reaction of inverter to an internal thermal overload condition.		
Value:	0: Reduce output frequency and output current 1: No reduction, trip (F0004/ 5/ 6) when thermal limits reached 2: Reduce pulse frequency, output current and output frequency 3: Reduce pulse freq. only and trip (F0006) when overload too high		
Dependency:	Following physical values influence the inverter overload protection (see diagram): <ul style="list-style-type: none"> Heat sink temperature (r0037[0]); causes A0504 and F0004. IGBT Junction temperature (r0037[1]); causes F0004 or F0006. Delta temperature between heat sink and junction temperature; causes A0504 and F0006. Inverter I2t (r0036); causes A0505 and F0005. 		

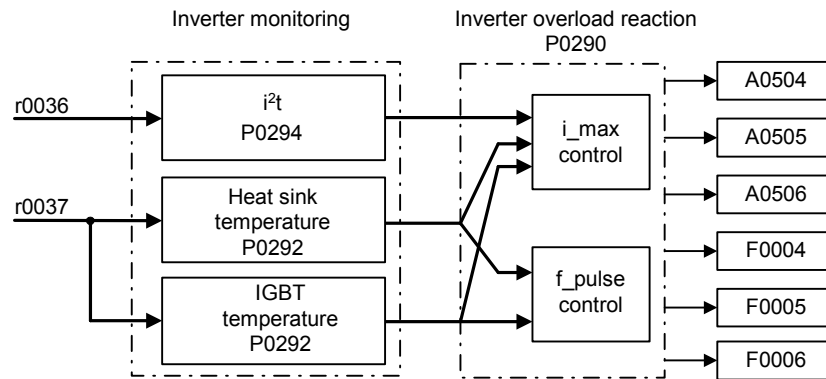

Notice:

P0290 = 0, 2:

- Reduction of output frequency is only effective if the load is also reduced. This is for example valid for light overload applications with a quadratic torque characteristic as pumps or fans.
- For settings P0290 = 0 or 2, the I-max controller will act upon the output current limit (`r0067`) in case of overtemperature.

P0290 = 0:

- With pulse frequencies above nominal, pulse frequency will be reduced to nominal immediately in the event of `r0027` greater than `r0067` (current limit).

P0290 = 2, 3:

- The pulse frequency P1800 is reduced only if higher than 2 kHz and if the operating frequency is below 2 Hz.
- The actual pulse frequency is displayed in parameter `r1801[0]` and the minimal pulse frequency for reduction is displayed in `r1801[1]`.
- Inverter `I2t` acts upon output current and output frequency, but not on pulse frequency.

A trip will always result, if the action taken does not sufficiently reduce internal temperatures.

p0291[0...2]

Inverter protection / Inverter protect.

Access level: 4	Calculated: -	Data type: Unsigned16
Can be changed: T	Scaling: -	Data set: DDS
Min	Max	Factory setting
-	-	0001 0001 bin

Description: Bit 02 shows if phase loss detection (input phase) of 3 phase inverters is enabled after factory reset. Default setting of phase loss is disabled for FSA - FSC.

Bit field:	Bit	Signal name	1 signal	0 signal	FP
	01	reserved	Yes	No	-
	02	Phase loss detection enable	Yes	No	-

Note: See P0290 (inverter overload reaction)

p0292

Inverter temperature warning / Inv. temp. warn.

Access level: 3	Calculated: -	Data type: Unsigned16
Can be changed: U, T	Scaling: -	Data set: -
Min	Max	Factory setting
0 [°C]	25 [°C]	5 [°C]

Description: Defines the temperature difference (in °C) between the overtemperature trip threshold (`F0004`) and the warning threshold (`A0504`) of the inverter.

The trip threshold is stored internally by the inverter and cannot be changed by the user.

p0294	Inverter I2t warning / Inv. I2t warn.		
	Access level: 4	Calculated: -	Data type: FloatingPoint32
	Can be changed: U, T	Scaling: -	Data set: -
	Min 10.0 [%]	Max 100.0 [%]	Factory setting 95.0 [%]
Description:	Defines the [%] value at which warning A0505 (inverter I2t) is generated. Inverter I2t calculation is used to determine a maximum tolerable period for inverter overload. The I2t calculation value is deemed = 100 % when this maximum tolerable period is reached.		
Dependency:	<ul style="list-style-type: none"> The output current of the inverter has been reduced. The value of I2t does not exceed 100 %. 		
Note:	P0294 = 100 % corresponds to stationary nominal load.		
p0295	Inverter fan off delay time / Fan delay time		
	Access level: 3	Calculated: -	Data type: Unsigned16
	Can be changed: U, T	Scaling: -	Data set: -
	Min 0 [s]	Max 3600 [s]	Factory setting 0 [s]
Description:	Defines inverter fan switch off delay time in seconds after drive has stopped.		
Note:	Setting to 0, inverter fan will switch off when the drive stops, that means no delay.		
p0300[0...2]	Select motor type / Select motor type		
	Access level: 2	Calculated: -	Data type: Unsigned16
	Can be changed: C(1)	Scaling: -	Data set: DDS
	Min 1	Max 2	Factory setting 1
Description:	<p>Selects motor type.</p> <p>This parameter is required during commissioning to select motor type and optimize inverter performance. Most motors are asynchronous; if in doubt, use the following formula .</p> $60 * P0310 / P0311$ <p>(the ratio of rated frequency (P0310) and rated motor speed (P0311))</p> <p>If the result is a whole number, the motor is synchronous.</p>		
Value:	<p>1: Asynchronous rotational motor</p> <p>2: Synchronous rotational motor</p>		
Dependency:	<p>Changeable only when P0010 = 1 (quick commissioning).</p> <p>P1233 DC braking</p> <p>If synchronous motor is selected, the following functions are not available:</p> <p>P0308 Power factor</p> <p>P0309 Motor efficiency</p> <p>P0346 Magnetization time</p> <p>P0347 Demagnetization time</p> <p>P1335 Slip compensation</p> <p>P1336 Slip limit</p> <p>P0320 Motor magnetizing current</p> <p>P0330 Rated motor slip</p> <p>P0331 Rated magnetization current</p> <p>P0332 Rated power factor</p> <p>P0384 Rotor time constant</p> <p>P1200, P1202, P1203 Flying start</p> <p>P1230, P1232, P1233 DC braking</p>		

p0304[0...2] Rated motor voltage / Rated mot. voltage

Access level: 1	Calculated: -	Data type: Unsigned16
Can be changed: C(1)	Scaling: -	Data set: DDS
Min 10 [V]	Max 2000 [V]	Factory setting 400 [V]

Description: Nominal motor voltage [V] from rating plate.
Dependency: Changeable only when P0010 = 1 (quick commissioning).
 Default value is depending on inverter type and its rating data.

Caution: The input of rating plate data must correspond with the wiring of the motor (star / delta).
 This means, if delta wiring is used for the motor, delta rating plate data has to be entered.



IEC Motor

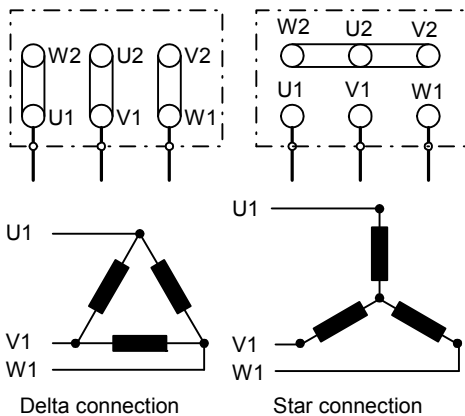

Note: Following diagram shows a typical rating plate with the locations of the relevant motor data.

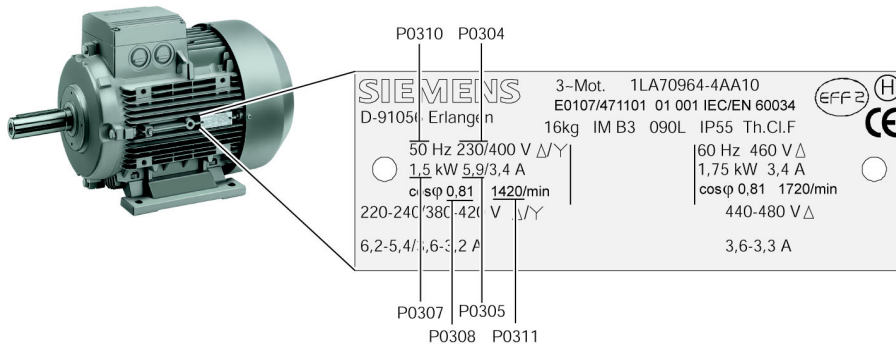

p0305[0...2] Rated motor current / Rated mot. current

Access level: 1	Calculated: -	Data type: FloatingPoint32
Can be changed: C(1)	Scaling: -	Data set: DDS
Min 0.01 [A]	Max 10000.00 [A]	Factory setting 1.86 [A]

Description: Nominal motor current [A] from rating plate.
Dependency: Changeable only when P0010 = 1 (quick commissioning).
 Depends also on P0320 (motor magnetization current).

Note: The maximum value of P0305 depends on the maximum inverter current r0209 and the motor type:
 Asynchronous motor : P0305_max = P0209
 Synchronous motor : P0305_max = 2 * P0209 (for HO operation) and P0305_max = P0209 (for LO operation)

It is recommended that the ratio of P0305 (rated motor current) and r0207 (rated inverter current) should not be lower than:

$$(1 / 8) \leq (p0305 / r0207)$$

When the relation of the nominal motor current P0305 and half of the maximal inverter current (r0209) exceeds 1.5 an additional current derating is applied. This is necessary to protect the inverter from harmonic current waves.

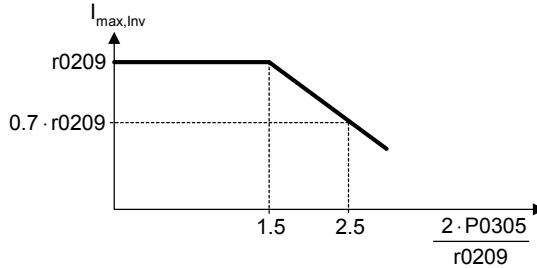

Default value is depending on inverter type and its rating data.

p0307[0...2]	Rated motor power / Rated motor power		
	Access level: 1	Calculated: -	Data type: FloatingPoint32
	Can be changed: C(1)	Scaling: -	Data set: DDS
	Min 0.01	Max 2000.00	Factory setting 0.75
Description:	Nominal motor power [kW/hp] from rating plate.		
Dependency:	If P0100 = 1, values will be in [hp]. Changeable only when P0010 = 1 (quick commissioning).		
Note:	Default value is depending on inverter type and its rating data.		

p0308[0...2]	Rated motor cosPhi / Rated mot. cosPhi		
	Access level: 1	Calculated: -	Data type: FloatingPoint32
	Can be changed: C(1)	Scaling: -	Data set: DDS
	Min 0.000	Max 1.000	Factory setting 0.000
Description:	Nominal motor power factor (cosPhi) from rating plate.		
Dependency:	Changeable only when P0010 = 1 (quick commissioning). Visible only when P0100 = 0 or 2, (motor power entered in [kW]). Setting 0 causes internal calculation of value. The value is displayed in r0332.		

p0309[0...2]	Rated motor efficiency / Rated efficiency		
	Access level: 1	Calculated: -	Data type: FloatingPoint32
	Can be changed: C(1)	Scaling: -	Data set: DDS
	Min 0.0 [%]	Max 99.9 [%]	Factory setting 0.0 [%]
Description:	Nominal motor efficiency in [%] from rating plate.		
Dependency:	Changeable only when P0010 = 1 (quick commissioning). Visible only when P0100 = 1, (i.e. motor power entered in [hp]). Setting 0 causes internal calculation of value. The value is displayed in r0332.		

p0310[0...2]	Rated motor frequency / Rated motor freq.		
	Access level: 1	Calculated: -	Data type: FloatingPoint32
	Can be changed: C(1)	Scaling: -	Data set: DDS
	Min 12.00 [Hz]	Max 650.00 [Hz]	Factory setting 50.00 [Hz]
Description:	Nominal motor frequency [Hz] from rating plate.		
Dependency:	Changeable only when P0010 = 1 (quick commissioning). Pole pair number recalculated automatically if parameter is changed.		
Note:	Changes to P0310 can influence the maximum motor frequency. For further information see P1082.		
p0311[0...2]	Rated motor speed / Rated motor speed		
	Access level: 1	Calculated: -	Data type: Unsigned16
	Can be changed: C(1)	Scaling: -	Data set: DDS
	Min 0 [RPM]	Max 40000 [RPM]	Factory setting 1395 [RPM]
Description:	Nominal motor speed [rpm] from rating plate.		
Dependency:	Changeable only when P0010 = 1 (quick commissioning). Setting 0 causes internal calculation of value. Slip compensation in V/f control requires rated motor speed for correct operation. Pole pair number recalculated automatically if parameter is changed.		
Note:	Default value is depending on inverter type and its rating data.		
r0313[0...2]	Motor pole pairs / Motor pole pairs		
	Access level: 3	Calculated: -	Data type: Unsigned16
	Unit: -	Scaling: -	Data set: DDS
Description:	Displays number of motor pole pairs that the inverter is currently using for internal calculations.		
Dependency:	Recalculated automatically when P0310 (rated motor frequency) or P0311 (rated motor speed) is changed. r0313 = 1 : 2-pole motor r0313 = 2 : 4-pole motor etc.		
p0314[0...2]	Motor pole pair number / Motor pole pair no		
	Access level: 3	Calculated: -	Data type: Unsigned16
	Can be changed: C(1)	Scaling: -	Data set: DDS
	Min 0	Max 99	Factory setting 0
Description:	Specifies number of pole pairs of motor.		
Dependency:	Changeable only when P0010 = 1 (quick commissioning). Setting 0 causes r0313 (calculated motor pole pairs) to be used during operation. Setting to > 0 overrides r0313. P0314 = 1 : 2-pole motor P0314 = 2 : 4-pole motor etc.		

p0320[0...2]	Motor magnetizing current / Motor magnet. cur.		
	Access level: 3	Calculated: -	Data type: FloatingPoint32
	Can be changed: C(1), T	Scaling: -	Data set: DDS
	Min 0.0 [%]	Max 99.0 [%]	Factory setting 0.0 [%]
Description:	Defines motor magnetization current in [%] relative to P0305 (rated motor current).		
Dependency:	Setting 0 causes calculation by P0340 = 1 (data entered from rating plate) or by P3900 = 1 - 3 (end of quick commissioning). The calculated value is displayed in parameter r0331.		
r0330[0...2]	Rated motor slip / Rated motor slip		
	Access level: 3	Calculated: -	Data type: FloatingPoint32
	Unit: [%]	Scaling: PERCENT	Data set: DDS
Description:	Displays nominal motor slip in [%] relative to P0310 (rated motor frequency) and P0311 (rated motor speed). $r0330[\%] = ((p0310 - r0313 * (p0311 / 60)) / p0310) * 100\%$		
r0331[0...2]	Rated magnetization current / Rated magnet. cur.		
	Access level: 3	Calculated: -	Data type: FloatingPoint32
	Unit: [A]	Scaling: -	Data set: DDS
Description:	Displays calculated magnetizing current of motor in [A].		
r0332[0...2]	Rated power factor / Rated power factor		
	Access level: 3	Calculated: -	Data type: FloatingPoint32
	Unit: -	Scaling: -	Data set: DDS
Description:	Displays power factor for motor.		
Dependency:	Value is calculated internally if P0308 (rated motor cosPhi) set to 0; otherwise, value entered in P0308 is displayed.		
r0333[0...2]	Rated motor torque / Rated motor torque		
	Access level: 3	Calculated: -	Data type: FloatingPoint32
	Unit: [Nm]	Scaling: -	Data set: DDS
Description:	Displays rated motor torque.		
Dependency:	Value is calculated from P0307 (rated motor power) and P0311 (rated motor speed). $r0333[\text{Nm}] = (p0307[\text{kW}] * 1000) / ((p0311[1/\text{min}] / 60) * 2 * \text{Pi})$		
p0335[0...2]	Motor cooling / Motor cooling		
	Access level: 2	Calculated: -	Data type: Unsigned16
	Can be changed: C(1), T	Scaling: -	Data set: DDS
	Min 0	Max 3	Factory setting 0
Description:	Selects motor cooling system used.		
Value:	0: Self-cooled: Shaft mounted fan attached motor (IC410 or IC411) 1: Force-cooled: Separately powered cooling fan (IC416) 2: Self-cooled and internal fan 3: Force-cooled and internal fan		

p0340[0...2] Calculation of motor parameters / Calc of mot.params**Access level:** 2**Calculated:** -**Data type:** Unsigned16**Can be changed:** T**Scaling:** -**Data set:** DDS**Min****Max****Factory setting**

0

4

0

Description: Calculates various motor parameters.

	P0340 = 1	P0340 = 2	P0340 = 3	P0340 = 4
P0341[0...2] Motor inertia [kg*m^2]	x			
P0342[0...2] Total/motor inertia ratio	x			
P0344[0...2] Motor weight	x			
P0346[0...2] Magnetization time	x		x	
P0347[0...2] Demagnetization time	x		x	
P0350[0...2] Stator resistance (line-to-line)	x	x		
P0352[0...2] Cable resistance	x	x		
P0354[0...2] Rotor resistance	x	x		
P0356[0...2] Stator leakage inductance	x	x		
P0358[0...2] Rotor leakage inductance	x	x		
P0360[0...2] Main inductance	x	x		
P0362[0...2] Magnetizing curve flux 1	x	x		
P0363[0...2] Magnetizing curve flux 2	x	x		
P0364[0...2] Magnetizing curve flux 3	x	x		
P0365[0...2] Magnetizing curve flux 4	x	x		
P0366[0...2] Magnetizing curve imag 1	x	x		
P0367[0...2] Magnetizing curve imag 2	x	x		
P0368[0...2] Magnetizing curve imag 3	x	x		
P0369[0...2] Magnetizing curve imag 4	x	x		
P0625[0...2] Ambient motor temperature	x	x		
P1253[0...2] Controller output limitation	x		x	
P1316[0...2] Boost end frequency	x		x	
P1338[0...2] Resonance damping gain V/f	x		x	x
P1341[0...2] I _{max} controller integral time	x		x	x
P1345[0...2] I _{max} voltage ctrl. prop. gain	x		x	x
P1346[0...2] I _{max} voltage ctrl. integral time	x		x	x
P2002[0...2] Reference current	x			
P2003[0...2] Reference torque	x			
P2185[0...2] Upper torque threshold 1	x			
P2187[0...2] Upper torque threshold 2	x			
P2189[0...2] Upper torque threshold 3	x			

Value:

- 0: No calculation
- 1: Complete parameterization
- 2: Calculation of equivalent circuit data
- 3: Calculation of V/f control data
- 4: Calculation of controller settings only

Note: This parameter is required during commissioning to optimize inverter performance. If there is a large mismatch in Power ratings of Inverter to Motor it is possible that r0384 and r0386 may not be calculated correct. In these cases use P1910.

When transferring parameter p0340, the frequency inverter uses its processor to carry-out internal calculations. Communications - both via USS as well as via the Fieldbus - are interrupted for the time that it takes to make these calculations.

This can result in the following error messages at the connected SIMATIC S7 control (communications via fieldbus):

- Parameter fault 30
- Drive fault 70
- Drive fault 75

When using STARTER (USS) to commission the drive system, data cannot be entered while these calculations are being made.

The faults can be acknowledged as soon as the calculations have been completed in the frequency inverter. These calculations can take up to one minute to complete.

p0341[0...2]	Motor inertia [kg*m²] / Inertia [kg*m²]		
	Access level: 3	Calculated: p0340 = 1	Data type: FloatingPoint32
	Can be changed: U, T	Scaling: -	Data set: DDS
	Min 0.00010	Max 1000.00000	Factory setting 0.00180
Description:	Sets no-load inertia of motor.		
Note:	P0341 * P0342 (inertia ratio total/motor) = total motor inertia		
p0342[0...2]	Total/motor inertia ratio / Tot/mot inert.rat.		
	Access level: 3	Calculated: p0340 = 1	Data type: FloatingPoint32
	Can be changed: U, T	Scaling: -	Data set: DDS
	Min 1.000	Max 400.000	Factory setting 1.000
Description:	Specifies ratio between total inertia (load + motor) and motor inertia.		
p0344[0...2]	Motor weight / Motor weight		
	Access level: 3	Calculated: p0340 = 1	Data type: FloatingPoint32
	Can be changed: U, T	Scaling: -	Data set: DDS
	Min 1.0 [kg]	Max 6500.0 [kg]	Factory setting 9.4 [kg]
Description:	Specifies motor weight [kg].		
Note:	This value is used in the motor thermal model. It is normally calculated automatically from P0340 (motor parameters) but can also be entered manually. Default value is depending on inverter type and its rating data.		
r0345[0...2]	Motor start-up time / Mot. start-up time		
	Access level: 3	Calculated: -	Data type: FloatingPoint32
	Unit: [s]	Scaling: -	Data set: DDS
Description:	Displays motor start-up time. This time corresponds to the standardized motor inertia. The start-up time is the time taken to reach rated motor speed from standstill at acceleration with rated motor torque (r0333).		
p0346[0...2]	Magnetization time / Magnetization time		
	Access level: 3	Calculated: p0340 = 1,3	Data type: FloatingPoint32
	Can be changed: U, T	Scaling: -	Data set: DDS
	Min 0.000 [s]	Max 20.000 [s]	Factory setting 1.000 [s]
Description:	Sets magnetization time [s], i.e. waiting time between pulse enable and start of ramp-up. Motor magnetization builds up during this time. Magnetization time is normally calculated automatically from the motor data and corresponds to the rotor time constant.		
Notice:	An excessive reduction of this time can result in insufficient motor magnetization.		

Note: If boost settings are higher than 100 %, magnetization time may be reduced.
Default value is depending on inverter type and its rating data.

p0347[0...2]	Demagnetization time / Demagnet. time		
	Access level: 3	Calculated: p0340 = 1,3	Data type: FloatingPoint32
	Can be changed: U, T	Scaling: -	Data set: DDS
	Min 0.000 [s]	Max 20.000 [s]	Factory setting 1.000 [s]
Description:	Changes time allowed after OFF2 / fault condition, before pulses can be re-enabled.		
Notice:	Not active following a normally completed ramp-down, e.g. after OFF1, OFF3 or JOG. Overcurrent trips will occur if the time is decreased excessively.		
Note:	The demagnetization time is approximately 2.5 x rotor time constant in seconds. Default value is depending on inverter type and its rating data.		

p0350[0...2]	Stator resistance (line) / Stator res. (L)		
	Access level: 3	Calculated: p0340 = 1,2	Data type: FloatingPoint32
	Can be changed: U, T	Scaling: -	Data set: DDS
	Min 0.00001 [Ohm]	Max 2000.00000 [Ohm]	Factory setting 2.00000 [Ohm]
Description:	Stator resistance value in [Ohms] for connected motor (line value). The parameter value doesn't include the cable resistance.		
Note:	There are three ways to determine the value for this parameter: <ol style="list-style-type: none"> 1. Calculate using <ul style="list-style-type: none"> - P0340 = 1 (data entered from rating plate) or - P0010 = 1, P3900 = 1, 2 or 3 (end of quick commissioning). 2. Measure using P1900 = 2 (standard motor data identification - value for stator resistance is overwritten). Measure using P1900 = 3 (complete motor data identification - same like setting 2; additional detection of the saturation curve) 3. Measure manually using an Ohmmeter. <p>Since the manually measured resistor is a line-to-line value, which includes the cable resistors, the measured value has to be divided by two and the cable resistor of a line has to be subtracted from that value. The value entered in P0350 (stator resistance) is the one obtained by the method last used. Default value is depending on inverter type and its rating data.</p>		

p0352[0...2]	Cable resistance / Cable resistance		
	Access level: 3	Calculated: p0340 = 1,2	Data type: FloatingPoint32
	Can be changed: U, T	Scaling: -	Data set: DDS
	Min 0.0 [Ohm]	Max 120.0 [Ohm]	Factory setting 0.0 [Ohm]
Description:	Describes cable resistance between inverter and motor for one phase. The value corresponds to the resistance of the cable between the inverter and the motor, relative to the rated impedance.		

p0354[0...2]	Rotor resistance / Rotor resistance		
	Access level: 3	Calculated: p0340 = 1,2	Data type: FloatingPoint32
	Can be changed: U, T	Scaling: -	Data set: DDS
	Min 0.0 [Ohm]	Max 300.0 [Ohm]	Factory setting 10.0 [Ohm]
Description:	Sets rotor resistance of motor equivalent circuit (phase value).		
Dependency:	Calculated automatically using the motor model or determined using P1900 (motor identification).		

p0356[0...2]	Stator leakage inductance / Stator leak.induct		
	Access level: 3	Calculated: p0340 = 1,2	Data type: FloatingPoint32
	Can be changed: U, T	Scaling: -	Data set: DDS
	Min 0.00001 [mH]	Max 1000.00000 [mH]	Factory setting 10.00000 [mH]
Description:	Sets stator leakage inductance [mH] of motor equivalent circuit (phase value).		
Dependency:	Calculated automatically using the motor model or determined using P1900 (motor identification).		
p0358[0...2]	Rotor leakage inductance / Rotor leak.induct.		
	Access level: 3	Calculated: p0340 = 1,2	Data type: FloatingPoint32
	Can be changed: U, T	Scaling: -	Data set: DDS
	Min 0.0 [mH]	Max 1000.0 [mH]	Factory setting 10.0 [mH]
Description:	Sets rotor leakage inductance [mH] of motor equivalent circuit (phase value).		
Dependency:	Calculated automatically using the motor model or determined using P1900 (motor identification).		
p0360[0...2]	Main inductance / Main inductance		
	Access level: 3	Calculated: p0340 = 1,2	Data type: FloatingPoint32
	Can be changed: U, T	Scaling: -	Data set: DDS
	Min 0.0 [mH]	Max 10000.0 [mH]	Factory setting 10.0 [mH]
Description:	Sets main inductance [mH] of the motor equivalent circuit (phase value).		
Dependency:	Calculated automatically using the motor model or determined using P1900 (motor identification).		
Caution:	The data of equivalent circuit relates to the star equivalent circuit.		
	Any data of the delta equivalent circuit available, therefore must be transformed to the star equivalent circuit before entering into the inverter.		
p0362[0...2]	Magnetizing curve flux 1 / Magnet.curve flux1		
	Access level: 4	Calculated: p0340 = 1,2	Data type: FloatingPoint32
	Can be changed: U, T	Scaling: PERCENT	Data set: DDS
	Min 20.0 [%]	Max 200.0 [%]	Factory setting 60.0 [%]
Description:	Specifies first flux value of saturation characteristic in [%] relative to rated motor voltage (P0304). The saturation characteristic is defined using 4 points (P0362 - P0365, P0366 - P0369). This parameter specifies the y coordinate (flux) for the first value pair of the characteristic.		
Dependency:	The following applies for the flux values: P0362 < P0363 < P0364 < P0365, otherwise a linear characteristic is applied internally.		
Note:	P0362 = 100 % corresponds to rated motor flux. Rated flux = rated EMF		
p0363[0...2]	Magnetizing curve flux 2 / Magnet.curve flux2		
	Access level: 4	Calculated: p0340 = 1,2	Data type: FloatingPoint32
	Can be changed: U, T	Scaling: PERCENT	Data set: DDS
	Min 20.0 [%]	Max 200.0 [%]	Factory setting 85.0 [%]
Description:	Specifies second flux value of saturation characteristic in [%] relative to rated motor voltage (P0304). The saturation characteristic is defined using 4 points (P0362 - P0365, P0366 - P0369). This parameter specifies the y coordinate (flux) for the second value pair of the characteristic.		
Dependency:	The following applies for the flux values: P0362 < P0363 < P0364 < P0365, otherwise a linear characteristic is applied internally.		

Note: P0363 = 100 % corresponds to rated motor flux.
Rated flux = rated EMF

p0364[0...2]	Magnetizing curve flux 3 / Magnet.curve flux3		
	Access level: 4	Calculated: p0340 = 1,2	Data type: FloatingPoint32
	Can be changed: U, T	Scaling: PERCENT	Data set: DDS
	Min 20.0 [%]	Max 200.0 [%]	Factory setting 115.0 [%]
Description:	Specifies third flux value of saturation characteristic in [%] relative to rated motor voltage (P0304). The saturation characteristic is defined using 4 points (P0362 - P0365, P0366 - P0369). This parameter specifies the y coordinate (flux) for the third value pair of the characteristic.		
Dependency:	The following applies for the flux values: P0362 < P0363 < P0364 < P0365, otherwise a linear characteristic is applied internally.		
Note:	P0364 = 100 % corresponds to rated motor flux. Rated flux = rated EMF		

p0365[0...2]	Magnetizing curve flux 4 / Magnet.curve flux4		
	Access level: 4	Calculated: p0340 = 1,2	Data type: FloatingPoint32
	Can be changed: U, T	Scaling: PERCENT	Data set: DDS
	Min 20.0 [%]	Max 200.0 [%]	Factory setting 125.0 [%]
Description:	Specifies fourth flux value of saturation characteristic in [%] relative to rated motor voltage (P0304). The saturation characteristic is defined using 4 points (P0362 - P0365, P0366 - P0369). This parameter specifies the y coordinate (flux) for the fourth value pair of the characteristic.		
Dependency:	The following applies for the flux values: P0362 < P0363 < P0364 < P0365, otherwise a linear characteristic is applied internally.		
Note:	P0365 = 100 % corresponds to rated motor flux. Rated flux = rated EMF		

p0366[0...2]	Magnetizing curve imag 1 / Magnet.curve imag1		
	Access level: 4	Calculated: p0340 = 1,2	Data type: FloatingPoint32
	Can be changed: U, T	Scaling: PERCENT	Data set: DDS
	Min 20.0 [%]	Max 250.0 [%]	Factory setting 50.0 [%]
Description:	Specifies first magnetizing current value of the saturation characteristic in [%] relative to the rated magnetizing current (P0331). The saturation characteristic is defined using 4 points (P0362 - P0365, P0366 - P0369). This parameter specifies the x coordinate (magnetizing current) for the first value pair of the characteristic.		
Dependency:	Affects P0320 (motor magnetizing current). The following applies for the magnetizing currents: P0366 < P0367 < P0368 < P0369, otherwise a linear characteristic is applied internally.		

p0367[0...2]	Magnetizing curve imag 2 / Magnet.curve imag2		
	Access level: 4	Calculated: p0340 = 1,2	Data type: FloatingPoint32
	Can be changed: U, T	Scaling: PERCENT	Data set: DDS
	Min 20.0 [%]	Max 250.0 [%]	Factory setting 75.0 [%]
Description:	Specifies second magnetizing current value of the saturation characteristic in [%] relative to rated magnetizing current (P0331). The saturation characteristic is defined using 4 points (P0362 - P0365, P0366 - P0369). This parameter specifies the x coordinate (magnetizing current) for the second value pair of the characteristic.		

Dependency:	Affects P0320 (motor magnetizing current). The following applies for the magnetizing currents: P0366 < P0367 < P0368 < P0369, otherwise a linear characteristic is applied internally.		
p0368[0...2]	Magnetizing curve imag 3 / Magnet.curve imag3		
	Access level: 4	Calculated: p0340 = 1,2	Data type: FloatingPoint32
	Can be changed: U, T	Scaling: PERCENT	Data set: DDS
	Min 20.0 [%]	Max 250.0 [%]	Factory setting 135.0 [%]
Description:	Specifies third magnetizing current value of the saturation characteristic in [%] relative to rated magnetizing current (P0331). The saturation characteristic is defined using 4 points (P0362 - P0365, P0366 - P0369). This parameter specifies the x coordinate (magnetizing current) for the third value pair of the characteristic.		
Dependency:	Affects P0320 (motor magnetizing current). The following applies for the magnetizing currents: P0366 < P0367 < P0368 < P0369, otherwise a linear characteristic is applied internally.		
p0369[0...2]	Magnetizing curve imag 4 / Magnet.curve imag4		
	Access level: 4	Calculated: p0340 = 1,2	Data type: FloatingPoint32
	Can be changed: U, T	Scaling: PERCENT	Data set: DDS
	Min 20.0 [%]	Max 250.0 [%]	Factory setting 170.0 [%]
Description:	Specifies fourth magnetizing current value of the saturation characteristic in [%] relative to rated magnetizing current (P0331). The saturation characteristic is defined using 4 points (P0362 - P0365, P0366 - P0369). This parameter specifies the x coordinate (magnetizing current) for the fourth value pair of the characteristic.		
Dependency:	Affects P0320 (motor magnetizing current). The following applies for the magnetizing currents: P0366 < P0367 < P0368 < P0369, otherwise a linear characteristic is applied internally.		
r0370[0...2]	Stator resistance [%] / Stator res. [%]		
	Access level: 4	Calculated: -	Data type: FloatingPoint32
	Unit: [%]	Scaling: PERCENT	Data set: DDS
Description:	Displays standardized stator resistance of motor equivalent circuit (phase value) in [%].		
r0372[0...2]	Cable resistance [%] / Cable res. [%]		
	Access level: 4	Calculated: -	Data type: FloatingPoint32
	Unit: [%]	Scaling: PERCENT	Data set: DDS
Description:	Displays standardized cable resistance of motor equivalent circuit (phase value) in [%]. It is estimated to be 20 % of the stator resistance.		
r0373[0...2]	Rated stator resistance [%] / Rated stat.res.[%]		
	Access level: 4	Calculated: -	Data type: FloatingPoint32
	Unit: [%]	Scaling: PERCENT	Data set: DDS
Description:	Displays rated stator resistance of the motor equivalent circuit (phase value) in [%].		
r0374[0...2]	Rotor resistance [%] / Rotor res. [%]		
	Access level: 4	Calculated: -	Data type: FloatingPoint32
	Unit: [%]	Scaling: PERCENT	Data set: DDS
Description:	Displays standardized rotor resistance of the motor equivalent circuit (phase value) in [%].		

r0376[0...2]	Rated rotor resistance [%] / Rated rot. res. [%]		
	Access level: 4	Calculated: -	Data type: FloatingPoint32
	Unit: [%]	Scaling: PERCENT	Data set: DDS
Description:	Displays rated rotor resistance of the motor equivalent circuit (phase value) in [%].		
r0377[0...2]	Total leakage reactance [%] / Tot.leak.react. [%]		
	Access level: 4	Calculated: -	Data type: FloatingPoint32
	Unit: [%]	Scaling: PERCENT	Data set: DDS
Description:	Displays standardized total leakage reactance of the motor equivalent circuit (phase value) in [%].		
r0382[0...2]	Main reactance [%] / Main reactance [%]		
	Access level: 4	Calculated: -	Data type: FloatingPoint32
	Unit: [%]	Scaling: PERCENT	Data set: DDS
Description:	Displays standardized main reactance of the motor equivalent circuit (phase value) in [%].		
r0384[0...2]	Rotor time constant / Rotor time const.		
	Access level: 3	Calculated: -	Data type: FloatingPoint32
	Unit: [ms]	Scaling: -	Data set: DDS
Description:	Displays calculated rotor time constant [ms].		
r0386[0...2]	Total leakage time constant / Total leak. Tconst		
	Access level: 4	Calculated: -	Data type: FloatingPoint32
	Unit: [ms]	Scaling: -	Data set: DDS
Description:	Displays total leakage time constant of motor.		
r0395	CO: Total stator resistance [%] / Total stat.res		
	Access level: 3	Calculated: -	Data type: FloatingPoint32
	Unit: [%]	Scaling: PERCENT	Data set: -
Description:	Displays stator resistance of motor as [%] of combined stator/cable resistance.		
p0500[0...2]	Technological application / Techn. application		
	Access level: 3	Calculated: -	Data type: Unsigned16
	Can be changed: C(1), T	Scaling: -	Data set: DDS
	Min 0	Max 1	Factory setting 0
Description:	Selects technological application. Sets control mode (P1300).		
Value:	0: High overload 1: Pumps and fans		
Dependency:	See parameter P0205.		

Parameter	Description	Access level	Calculated	Data type
p0601[0...2]	Motor temperature sensor / Motor temp. sensor	2	-	Unsigned16
		Can be changed: U, T	Scaling: -	Data set: DDS
		Min 0	Max 8	Factory setting 0
Description:	Selects motor temperature sensor.			
Value:	0: No sensor 1: PTC thermistor 2: KTY84 4: ThermoClick sensor 6: PT1000 8: PTC therm w/o S/C			
Dependency:	The motor overheating warning threshold needs to be assigned with parameter P0604 (factory setting: 130 °C). This warning threshold depends on the motor's thermal class. The motor overheating disturbance threshold is automatically set by the inverter at 10 % higher than the temperature declared in parameter P0604. In parameter P0610 is set, how the inverter reacts on overtemperature.			
Note:	<ul style="list-style-type: none"> • P0601 = 0 (No sensor) The motor temperature monitoring will be done based on the estimated value of the thermal motor model. • P0601 = 1 (PTC thermistor) The motor is monitored by the thermal motor model and additionally by the PTC thermistor, thus providing a redundant system for monitoring the motor temperature. Should the resistance value of 2000 Ohm be exceeded, the inverter trips with fault F0011 (motor overheating). If the resistance value is below 50 Ohm, then the fault F0015 (motor temperature signal lost) is output. This protects the motor from overheating and also from a sensor wire breakage. There is a time delay before drive trips F011/F015. • P0601 = 2 (KTY84) The temperature of the sensor (thus that of the motor windings) is written to parameter r0035. This motor temperature is then additionally calculated via the thermal motor model. If the electric circuit to the KTY84 sensor is open or if a short circuit occurs, fault F0015 (motor temperature signal lost) is generated. • P0601 = 4 (ThermoClick sensor) The motor is monitored by the thermal motor model and additionally by the ThermoClick sensor, thus providing a redundant system for monitoring the motor temperature. Should the resistance value of 2000 Ohm be exceeded, the inverter trips with fault F0011 (motor overheating). This protects the motor from overheating and also from a sensor wire breakage. There is a time delay before drive trips F011. • P0601 = 6 (PT1000) The temperature of the sensor (thus that of the motor windings) is written to parameter r0035. This motor temperature is then additionally calculated via the thermal motor model. If the electric circuit to the PT1000 sensor is open or if a short circuit occurs, fault F0015 (motor temperature signal lost) is generated. • P0601 = 8 (PTC thermistor) no short circuit protection The motor is monitored by the thermal motor model and additionally by the PTC thermistor, thus providing a redundant system for monitoring the motor temperature. Should the resistance value of 2000 Ohm be exceeded, the inverter trips with fault F0011 (motor overheating). There is no motor temperature signal lost detection in this mode. There is a time delay before drive trips F011. 			
p0604[0...2]	Threshold motor temperature / Thresh. mot. temp.	2	-	FloatingPoint32
		Can be changed: U, T	Scaling: -	Data set: DDS
		Min 0.0 [°C]	Max 200.0 [°C]	Factory setting 130.0 [°C]
Description:	Enters warning threshold for motor temperature protection. The trip temperature defined is always 10 % higher than the warning threshold P0604. When actual motor temperature exceeds warning temperature then inverter reacts as defined in P0610.			
Dependency:	This value should be at least 40°C higher than the motor ambient temperature P0625.			
Note:	Default value depends on P0300 (select motor type).			

p0610[0...2]	Motor I2t temperature reaction / I2t temp. reaction		
	Access level: 3	Calculated: -	Data type: Unsigned16
	Can be changed: T	Scaling: -	Data set: DDS
	Min 0	Max 6	Factory setting 6
Description:	Defines reaction when motor temperature reaches warning threshold.		
Value:	0: Warning, no reaction, no trip 1: Warning, I _{max} reduction, trip F0011 2: Warning, no reaction, trip F0011 4: Warning, no reaction, no trip, save temp. on power down. 5: Warning, I _{max} reduction, trip F0011, save temp. on power down. 6: Warning, no reaction, trip F0011, save temp. on power down.		
Dependency:	Trip level = P0604 (motor temperature threshold) * 110 %		
Note:	<ul style="list-style-type: none"> • P0610 = 0 (No reaction, warning only) When temperature reaches warning level defined in P604, the drive displays warning A511, no reaction is done. • P0610 = 1 (Warning, I_{max} reduction and Trip) When temperature reaches warning level defined in P604, the drive displays warning A511, reduce frequency and trips F011, when temperature exceeds the trip level. • P0610 = 2 (Warning and trip F0011) When temperature reaches warning level defined in P604, the drive displays warning A511 and trips F011, when temperature exceeds the trip level. The purpose of motor I2t is to calculate or measure (KTY84) the motor temperature and disable the inverter if the motor is in danger of overheating. I2t operation: The measured motor current is displayed in r0027. The motor temperature in °C is displayed in r0035. This temperature is derived either from a KTY84 temperature sensor mounted in the motor, or from a calculated value. The value from the KTY84 is used only when P0601 = 2; in all other cases (including motor temperature signal lost) the calculated value is used. The reaction to the warning can be changed from this default using P0610. Parameter r0035 is particularly useful to monitor if the calculated motor temperature is rising excessively. 		
p0622[0...2]	Magnetizing time for temp id after start up / Magnet. t temp id		
	Access level: 3	Calculated: -	Data type: FloatingPoint32
	Can be changed: U, T	Scaling: -	Data set: DDS
	Min 0.000 [ms]	Max 20000.000 [ms]	Factory setting 0.000 [ms]
Description:	Specifies the magnetization time for stator resistance identification.		
Note:	This parameter will be set as a result of the motor data identification according to the identified rotor time constant r1913.		
p0625[0...2]	Ambient motor temperature / Ambient mot. temp.		
	Access level: 3	Calculated: p0340 = 1,2	Data type: FloatingPoint32
	Can be changed: C(1), U, T	Scaling: -	Data set: DDS
	Min -40.0 [°C]	Max 80.0 [°C]	Factory setting 20.0 [°C]
Description:	Ambient temperature of motor at time of motor data identification. It is only allowed to change the value when the motor is cold. A motor identification has to be made after changing the value.		

p0626[0...2]	Overtemperature stator iron / Overtemp.stat.iron		
	Access level: 4	Calculated: -	Data type: FloatingPoint32
	Can be changed: U, T	Scaling: -	Data set: DDS
	Min 20.0 [°C]	Max 200.0 [°C]	Factory setting 50.0 [°C]
Description:	Overtemperature of stator iron.		
Note:	Temperature rises are valid for sinusoidal operations (line supply temperature rises). Temperature rises due to converter operation (modulation losses) and output filter are also considered.		
p0627[0...2]	Overtemperature stator winding / Overtemp.stat.wind		
	Access level: 4	Calculated: -	Data type: FloatingPoint32
	Can be changed: U, T	Scaling: -	Data set: DDS
	Min 20.0 [°C]	Max 200.0 [°C]	Factory setting 80.0 [°C]
Description:	Overtemperature of the stator winding. It is only allowed to change the value when the motor is cold. A motor identification has to be made after changing the value.		
Note:	Temperature rises are valid for sinusoidal operations (line supply temperature rises). Temperature rises due to converter operation (modulation losses) and output filter are also considered.		
p0628[0...2]	Overtemperature rotor winding / Overtemp.rot. wind		
	Access level: 4	Calculated: -	Data type: FloatingPoint32
	Can be changed: U, T	Scaling: -	Data set: DDS
	Min 20.0 [°C]	Max 200.0 [°C]	Factory setting 100.0 [°C]
Description:	Overtemperature of the rotor winding.		
Note:	Temperature rises are valid for sinusoidal operations (line supply temperature rises). Temperature rises due to converter operation (modulation losses) and output filter are also considered.		
r0630[0...2]	CO: Motor model ambient temperature / Mot. model amb. te		
	Access level: 4	Calculated: -	Data type: FloatingPoint32
	Unit: [°C]	Scaling: -	Data set: DDS
Description:	Displays ambient temperature of motor mass model.		
r0631[0...2]	CO: Stator iron temperature / Stat.iron temp		
	Access level: 4	Calculated: -	Data type: FloatingPoint32
	Unit: [°C]	Scaling: -	Data set: DDS
Description:	Displays iron temperature of motor mass model.		
r0632[0...2]	CO: Stator winding temperature / Stat.wind.temp		
	Access level: 4	Calculated: -	Data type: FloatingPoint32
	Unit: [°C]	Scaling: -	Data set: DDS
Description:	Displays stator winding temperature of motor mass model.		
r0633[0...2]	CO: Rotor winding temperature / Rot. wind.temp		
	Access level: 4	Calculated: -	Data type: FloatingPoint32
	Unit: [°C]	Scaling: -	Data set: DDS
Description:	Displays rotor winding temperature of motor mass model.		

p0640[0...2]	Motor overload factor [%] / Motor ovl fact [%]		
	Access level: 2	Calculated: -	Data type: FloatingPoint32
	Can be changed: C(1), U, T	Scaling: -	Data set: DDS
	Min 10.0 [%]	Max 400.0 [%]	Factory setting 200.0 [%]
Description:	Defines motor overload current limit in [%] relative to P0305 (rated motor current).		
Dependency:	Limited to maximum inverter current or to 400 % of rated motor current (P0305), whichever is the lower. p0640_max = (min(r0209, 4 * p0305) / p0305) * 100		
Note:	Changes to P0640 will be effective only after the next off state.		

p0700[0...2]	Selection of command source / Command source sel		
	Access level: 1	Calculated: -	Data type: Unsigned16
	Can be changed: C(1), T	Scaling: -	Data set: CDS
	Min 0	Max 6	Factory setting 6
Description:	Selects digital command source.		
Value:	0: Factory default setting 2: Terminal 4: USS on RS232 6: Fieldbus		
Dependency:	Changing this parameter sets (to default) all settings on item selected. These are the following parameters: P0701, ... (function of DI), P0800, P0801, P0840, P0842, P0844, P0845, P0848, P0849, P0852, P1020, P1021, P1022, P1023, P1035, P1036, P1055, P1056, P1074, P1110, P1113, P1124, P1140, P1141, P1142, P1230, P2103, P2104, P2106, P2200, P2220, P2221, P2222, P2223, P2235, P2236 USS on RS485 is not supported.		
Caution:	Be aware, by changing of parameter P0700 all BI parameters are reset to the default value.		



p0701[0...2]	Function of digital input 0 / Function of DI0		
	Access level: 2	Calculated: -	Data type: Unsigned16
	Can be changed: T	Scaling: -	Data set: CDS
	Min 0	Max 99	Factory setting 0
Description:	Selects function of digital input 0.		
Value:	0: Digital input disabled 1: ON/OFF1 2: ON reverse /OFF1 3: OFF2 - coast to standstill 4: OFF3 - quick ramp-down 9: Fault acknowledge 10: JOG right 11: JOG left 12: Reverse 13: MOP up (increase frequency) 14: MOP down (decrease frequency) 15: Fixed frequency selector bit0 16: Fixed frequency selector bit1 17: Fixed frequency selector bit2 18: Fixed frequency selector bit3 22: QuickStop Source 1 23: QuickStop Source 2 24: QuickStop Override 25: DC brake enable 27: Enable PID		

- 29: External trip
 33: Disable additional freq setpoint
 99: Enable BICO parameterization

Dependency: Setting 99 (enable BICO parameterization) requires:

- P0700 command source or
- P0010 = 1, P3900 = 1, 2 or 3 (quick commissioning) or
- P0010 = 30, P0970 = 1 factory reset in order to reset

Note: "ON/OFF1" can only be selected for one digital input (e.g. P0700 = 2 and P0701 = 1).
 Configuring DI1 with P0702 = 1 will disable DI0 by setting P0701 = 0. Only the last activated digital input serves as a command source.
 "ON/OFF1" on a digital input can be combined with "ON reverse/OFF1" on another digital input.

p0702[0...2]	Function of digital input 1 / Function of DI1		
	Access level: 2	Calculated: -	Data type: Unsigned16
	Can be changed: T	Scaling: -	Data set: CDS
	Min 0	Max 99	Factory setting 0
Description:	Selects function of digital input 1.		
Value:	0: Digital input disabled 1: ON/OFF1 2: ON reverse /OFF1 3: OFF2 - coast to standstill 4: OFF3 - quick ramp-down 9: Fault acknowledge 10: JOG right 11: JOG left 12: Reverse 13: MOP up (increase frequency) 14: MOP down (decrease frequency) 15: Fixed frequency selector bit0 16: Fixed frequency selector bit1 17: Fixed frequency selector bit2 18: Fixed frequency selector bit3 22: QuickStop Source 1 23: QuickStop Source 2 24: QuickStop Override 25: DC brake enable 27: Enable PID 29: External trip 33: Disable additional freq setpoint 99: Enable BICO parameterization		
Note:	See P0701 (function of digital input0).		

p0703[0...2]	Function of digital input 2 / Function of DI2		
	Access level: 2	Calculated: -	Data type: Unsigned16
	Can be changed: T	Scaling: -	Data set: CDS
	Min 0	Max 99	Factory setting 9
Description:	Selects function of digital input 2.		
Value:	0: Digital input disabled 1: ON/OFF1 2: ON reverse /OFF1 3: OFF2 - coast to standstill 4: OFF3 - quick ramp-down 9: Fault acknowledge 10: JOG right 11: JOG left 12: Reverse		

- 13: MOP up (increase frequency)
- 14: MOP down (decrease frequency)
- 15: Fixed frequency selector bit0
- 16: Fixed frequency selector bit1
- 17: Fixed frequency selector bit2
- 18: Fixed frequency selector bit3
- 22: QuickStop Source 1
- 23: QuickStop Source 2
- 24: QuickStop Override
- 25: DC brake enable
- 27: Enable PID
- 29: External trip
- 33: Disable additional freq setpoint
- 99: Enable BICO parameterization

Note: See P0701 (function of digital input 0).

p0704[0...2] Function of digital input 3 / Function of DI3

Access level: 2	Calculated: -	Data type: Unsigned16
Can be changed: T	Scaling: -	Data set: CDS
Min 0	Max 99	Factory setting 0

Description: Selects function of digital input 3.

- Value:**
- 0: Digital input disabled
 - 1: ON/OFF1
 - 2: ON reverse /OFF1
 - 3: OFF2 - coast to standstill
 - 4: OFF3 - quick ramp-down
 - 9: Fault acknowledge
 - 10: JOG right
 - 11: JOG left
 - 12: Reverse
 - 13: MOP up (increase frequency)
 - 14: MOP down (decrease frequency)
 - 15: Fixed frequency selector bit0
 - 16: Fixed frequency selector bit1
 - 17: Fixed frequency selector bit2
 - 18: Fixed frequency selector bit3
 - 22: QuickStop Source 1
 - 23: QuickStop Source 2
 - 24: QuickStop Override
 - 25: DC brake enable
 - 27: Enable PID
 - 29: External trip
 - 33: Disable additional freq setpoint
 - 99: Enable BICO parameterization

Note: See P0701 (function of digital input 0).

p0712[0...2] Analog / digital input 0 / Ana/digi input 0

Access level: 2	Calculated: -	Data type: Unsigned16
Can be changed: T	Scaling: -	Data set: CDS
Min 0	Max 99	Factory setting 0

Description: Selects function of digital input AI0 (via analog input)

- Value:**
- 0: Digital input disabled
 - 1: ON/OFF1
 - 2: ON reverse /OFF1
 - 3: OFF2 - coast to standstill
 - 4: OFF3 - quick ramp-down
 - 9: Fault acknowledge

10:	JOG right
11:	JOG left
12:	Reverse
13:	MOP up (increase frequency)
14:	MOP down (decrease frequency)
15:	Fixed frequency selector bit0
16:	Fixed frequency selector bit1
17:	Fixed frequency selector bit2
18:	Fixed frequency selector bit3
22:	QuickStop Source 1
23:	QuickStop Source 2
24:	QuickStop Override
25:	DC brake enable
27:	Enable PID
29:	External trip
33:	Disable additional freq setpoint
99:	Enable BICO parameterization

Note: See P0701 (function of digital input 0).
Signals above 4 V are active, signals below 1,6 V are inactive.

p0719[0...2] Selection of cmd. & freq. setp. / Cmd.&freq.setp.sel

Access level: 4	Calculated: -	Data type: Unsigned16
Can be changed: T	Scaling: -	Data set: CDS
Min	Max	Factory setting
0	66	0

Description: Central switch to select control command source for inverter.
Switches command and setpoint source between freely programmable BICO parameters and fixed command/setpoint profiles.

Command and setpoint sources can be changed independently.

The tens digit chooses the command source and the units digit chooses the setpoint source.

Value:

0:	Cmd = BICO parameter	Setpoint = BICO parameter
1:	Cmd = BICO parameter	Setpoint = MOP setpoint
2:	Cmd = BICO parameter	Setpoint = Analog setpoint
3:	Cmd = BICO parameter	Setpoint = Fixed frequency
4:	Cmd = BICO parameter	Setpoint = USS on RS232
6:	Cmd = BICO parameter	Setpoint = Fieldbus
11:	Cmd = OP	Setpoint = MOP setpoint
40:	Cmd = USS on RS232	Setpoint = BICO parameter
41:	Cmd = USS on RS232	Setpoint = MOP setpoint
42:	Cmd = USS on RS232	Setpoint = Analog setpoint
43:	Cmd = USS on RS232	Setpoint = Fixed frequency
44:	Cmd = USS on RS232	Setpoint = USS on RS232
46:	Cmd = USS on RS232	Setpoint = Fieldbus
60:	Cmd = Fieldbus	Setpoint = BICO parameter
61:	Cmd = Fieldbus	Setpoint = MOP setpoint
62:	Cmd = Fieldbus	Setpoint = Analog setpoint
63:	Cmd = Fieldbus	Setpoint = Fixed frequency
64:	Cmd = Fieldbus	Setpoint = USS on RS232
66:	Cmd = Fieldbus	Setpoint = Fieldbus

Dependency: P0719 has higher priority than P0700 and P1000.
If set to a value other than 0 (i.e. BICO parameter is not the setpoint source), P0844 / P0848 (first source of OFF2 / OFF3) are not effective; instead, P0845 / P0849 (second source of OFF2 / OFF3) apply and the OFF commands are obtained via the particular source defined.

BICO connections made previously remain unchanged.

Notice: Particularly useful when e.g. changing command source temporarily from P0700 = 2.
Settings in P0719 (contrary to P0700 settings) do not reset the digital inputs (P0701, P0702, ...)

r0720 **Number of digital inputs / Number of DI**
Access level: 3 **Calculated:** - **Data type:** Unsigned16
Unit: - **Scaling:** - **Data set:** -
Description: Displays number of digital inputs.

r0722.0...11 **CO/BO: Digital input values / Dig.inp.val**
Access level: 2 **Calculated:** - **Data type:** Unsigned16
Unit: - **Scaling:** - **Data set:** -
Description: Displays status of digital inputs.
Bit field:

Bit	Signal name	1 signal	0 signal	FP
00	Digital input 0	Yes	No	-
01	Digital input 1	Yes	No	-
02	Digital input 2	Yes	No	-
03	Digital input 3	Yes	No	-
11	Digital input AI0	Yes	No	-

Note: Segment is lit when signal is active.

p0724 **Debounce time for digital inputs / Debounce time: DI**
Access level: 3 **Calculated:** - **Data type:** Unsigned16
Can be changed: T **Scaling:** - **Data set:** -
Min **Max** **Factory setting**
0 3 3
Description: Defines debounce time (filtering time) used for digital inputs.
Value:
0: No debounce time
1: 2.5 ms debounce time
2: 8.2 ms debounce time
3: 12.3 ms debounce time

p0727[0...2] **Selection of 2/3-wire method / 2/3-wire selection**
Access level: 2 **Calculated:** - **Data type:** Unsigned16
Can be changed: C(1), T **Scaling:** - **Data set:** CDS
Min **Max** **Factory setting**
0 3 0
Description: Determines the control method using the terminals. This parameter allows the selection of the control philosophy. The control philosophies exclude each other.
Value:
0: Siemens(start/dir)
1: 2-wire (fwd/rev)
2: 3-wire (fwd/rev)
3: 3-wire (start/dir)
Note: Where:

- P denotes Pulse
- FWD denotes FORWARD
- REV denotes REVERSE

When any of the control functions are selected using P0727, the setting for the digital inputs (P0701 - P0704) are redefined as follows:

Redefined Digital Inputs

Settings P0701 - P0704	P0727 = 0 (Siemens Standard Control)	P0727 = 1 (2-wire Control)	P0727 = 2 (3-wire Control)	P0727 = 3 (3-wire Control)
1	ON/OFF1	ON_FWD	STOP	ON_PULSE
2	ON_REV/OFF1	ON_REV	FWDP	OFF1/HOLD
12	REV	REV	REVP	REV

Regarding the use of fixed frequencies see P1000 and P1001.

r0750	Number of AIs / Number of AIs			
	Access level: 3	Calculated: -	Data type: Unsigned16	
	Unit: -	Scaling: -	Data set: -	
Description:	Displays number of analog inputs available.			
r0751.0...8	CO/BO: Status word of AI / AI status Wd			
	Access level: 3	Calculated: -	Data type: Unsigned16	
	Unit: -	Scaling: -	Data set: -	
Description:	Displays status of analog input.			
Bit field:	Bit	Signal name	1 signal	0 signal
	00	Signal lost on AI0	Yes	No
	08	No signal lost on AI0	Yes	No
				FP
				-
				-
r0752[0]	Act. input of AI [V] or [mA] / Act.AI inp.[V/mA]			
	Access level: 2	Calculated: -	Data type: FloatingPoint32	
	Unit: -	Scaling: -	Data set: -	
Description:	Displays smoothed analog input value in volts or milliamps before the scaling block.			
Index:	[0] = Analog input 0 (AI0)			
p0753[0]	Smooth time AI / Smooth time AI			
	Access level: 3	Calculated: -	Data type: Unsigned16	
	Can be changed: U, T	Scaling: -	Data set: -	
	Min	Max	Factory setting	
	0 [ms]	10000 [ms]	3 [ms]	
Description:	Defines filter time (PT1 filter) in [ms] for analog input.			
Index:	[0] = Analog input 0 (AI0)			
Note:	Increasing this time (smooth) reduces jitter but slows down response to the analog input. P0753 = 0 : No filtering			
r0754[0]	Act. AI value after scaling [%] / AI after scal.[%]			
	Access level: 2	Calculated: -	Data type: FloatingPoint32	
	Unit: [%]	Scaling: -	Data set: -	
Description:	Shows smoothed value of analog input in [%] after scaling block.			
Index:	[0] = Analog input 0 (AI0)			
Dependency:	P0757 to P0760 define range (AI scaling).			

p0757[0]	Value x1 of AI scaling / Value x1:AI scal.		
	Access level: 2	Calculated: -	Data type: FloatingPoint32
	Can be changed: U, T	Scaling: -	Data set: -
	Min -20	Max 20	Factory setting 0
Description:	Parameters P0757 - P0760 configure the input scaling. x1 is the first value of the two pairs of variants x1/y1 and x2/y2 which determine the straight line. The value x2 of AI scaling P0759 must be greater than the value x1 of AI scaling P0757.		
Index:	[0] = Analog input 0 (AI0)		
Notice:	<ul style="list-style-type: none"> • Analog setpoints represent a [%] of the normalized frequency in P2000. • Analog setpoints may be larger than 100 %. • ASPmax represents highest analog setpoint (this may be at 10 V). • ASPmin represents lowest analog setpoint (this may be at 0 V). • Default values provide a scaling of 0 V = 0 %, and 10 V = 100 %. 		
p0758[0]	Value y1 of AI scaling / Value y1:AI scal.		
	Access level: 2	Calculated: -	Data type: FloatingPoint32
	Can be changed: U, T	Scaling: -	Data set: -
	Min -99999.9 [%]	Max 99999.9 [%]	Factory setting 0.0 [%]
Description:	Sets value of y1 in [%] as described in P0757 (AI scaling)		
Index:	[0] = Analog input 0 (AI0)		
Dependency:	Affects P2000 to P2003 (reference frequency, voltage, current or torque) depending on which setpoint is to be generated.		
p0759[0]	Value x2 of AI scaling / Value x2:AI scal.		
	Access level: 2	Calculated: -	Data type: FloatingPoint32
	Can be changed: U, T	Scaling: -	Data set: -
	Min -20	Max 20	Factory setting 10
Description:	Sets value of x2 as described in P0757 (AI scaling).		
Index:	[0] = Analog input 0 (AI0)		
Notice:	The value x2 of AI scaling P0759 must be greater than the value x1 of AI scaling P0757.		
p0760[0]	Value y2 of AI scaling / Value y2:AI scal.		
	Access level: 2	Calculated: -	Data type: FloatingPoint32
	Can be changed: U, T	Scaling: -	Data set: -
	Min -99999.9 [%]	Max 99999.9 [%]	Factory setting 100.0 [%]
Description:	Sets value of y2 in [%] as described in P0757 (AI scaling).		
Index:	[0] = Analog input 0 (AI0)		
Dependency:	Affects P2000 to P2003 (reference frequency, voltage, current or torque) depending on which setpoint is to be generated.		

p0761[0]	Width of AI deadband / AI deadband width		
	Access level: 2	Calculated: -	Data type: FloatingPoint32
	Can be changed: U, T	Scaling: -	Data set: -
	Min 0	Max 20	Factory setting 0
Description:	Defines width of deadband on analog input.		
Example:	The below example produces a 2 to 10 V, 0 to 50 Hz analog input (AI value 2 to 10 V, 0 to 50 Hz):		
	<ul style="list-style-type: none"> • P2000 = 50 Hz • P0759 = 8 V P0760 = 75 % • P0757 = 2 V P0758 = 0 % • P0761 = 2 V • P0756 = 0 or 1 		
	The below example produces a 0 to 10 V analog input (-50 to +50 Hz) with center zero and a "holding point" 0.2 V wide (0.1 V to each side of center, AI value 0 to 10 V, -50 to +50 Hz):		
	<ul style="list-style-type: none"> • P2000 = 50 Hz • P0759 = 8 V P0760 = 75 % • P0757 = 2 V P0758 = -75 % • P0761 = 0.1 V • P0756 = 0 or 1 		
Index:	[0] = Analog input 0 (AI0)		
Notice:	Deadband starts from 0 V to value of P0761, if both values of P0758 and P0760 (y coordinates of AI scaling) are positive or negative respectively. However, deadband is active in both directions from point of intersection (x axis with AI scaling curve), if sign of P0758 and P0760 are opposite.		
Note:	P0761[x] = 0 : No deadband active. Min. frequency P1080 should be zero when using center zero setup. There is no hysteresis at the end of the deadband.		

p0762[0]	Delay for loss of signal action / Delay on sig. loss		
	Access level: 3	Calculated: -	Data type: Unsigned16
	Can be changed: U, T	Scaling: -	Data set: -
	Min 0 [ms]	Max 10000 [ms]	Factory setting 10 [ms]
Description:	Defines time delay between loss of analog setpoint and appearance of fault code F0080.		
Index:	[0] = Analog input 0 (AI0)		
Note:	Expert users can choose the desired reaction to F0080 (default is OFF2).		

p0800[0...2]	BI: Download parameter set 0 / Dwnl.par.set 0		
	Access level: 3	Calculated: -	Data type: U32 / Binary
	Can be changed: T	Scaling: -	Data set: CDS
	Min -	Max -	Factory setting 0
Description:	Defines source of command to start download of parameter set 0 from attached OP. The first three digits describe the parameter number of the command source, the last digit refers to the bit setting for that parameter.		
Note:	Signal of digital input: 0 = No download 1 = Start download parameter set 0 from OP.		

p0801[0...2]	BI: Download parameter set 1 / Dwnl.par.set 1		
	Access level: 3	Calculated: -	Data type: U32 / Binary
	Can be changed: T	Scaling: -	Data set: CDS
	Min	Max	Factory setting
	-	-	0
Description:	Defines sources of command to start download of parameter set 1 from attached OP. The first three digits describe the parameter number of the command source, the last digit refers to the bit setting for that parameter.		
Note:	Signal of digital input: 0 = No download 1 = Start download parameter set 1 from OP.		
p0802	Transfer data from EEPROM / Transf.Drive->Ext		
	Access level: 3	Calculated: -	Data type: Unsigned16
	Can be changed: -	Scaling: -	Data set: -
	Min	Max	Factory setting
	0	2	0
Description:	Transfers values from drive to External device when none 0. Parameter P0010 must be set to 30 for this to be possible.		
Value:	0: Disabled 2: Start MMC Transfer		
Note:	Parameter is automatically reset to 0 (default) after transfer. P0010 will be reset to 0 on successful completion. Ensure that enough space exists on the MMC card before transferring data (8kb).		
p0803	Transfer data to EEPROM / Transf.Ext->Drive		
	Access level: 3	Calculated: -	Data type: Unsigned16
	Can be changed: -	Scaling: -	Data set: -
	Min	Max	Factory setting
	0	2	0
Description:	Transfers values from External to drive when none 0. Parameter P0010 must be set to 30 for this to be possible.		
Value:	0: Disabled 2: Start MMC Transfer		
Note:	Parameter is automatically reset to 0 (default) after transfer. P0010 will be reset to 0 on successful completion.		
p0804	Select Clone file / Select Clone file		
	Access level: 3	Calculated: -	Data type: Unsigned16
	Can be changed: -	Scaling: -	Data set: -
	Min	Max	Factory setting
	0	99	0
Description:	Select clone file to up/down load. if P0804 = 0 then file name is clone00.bin if P0804 = 1 then file name is clone01.bin etc.		

p0806	BI: Inhibit panel access / Inhibit panel acce			
	Access level: 3	Calculated: -	Data type: U32 / Binary	
	Can be changed: U, T	Scaling: -	Data set: -	
	Min	Max	Factory setting	
	-	-	0	
Description:	Binector input to lock control panel access through external client.			
r0807.0	BO: Displays client access / Displays client ac			
	Access level: 3	Calculated: -	Data type: Unsigned16	
	Unit: -	Scaling: -	Data set: -	
Description:	Binector output to display whether command and setpoint source is connected to an external client.			
Bit field:	Bit	Signal name	1 signal	0 signal
	00	Master control active	Yes	No
				FP
				-
p0809[0...2]	Copy Command Dataset (CDS) / Copy CDS			
	Access level: 2	Calculated: -	Data type: Unsigned16	
	Can be changed: T	Scaling: -	Data set: -	
	Min	Max	Factory setting	
	0	2	[0] 0	
			[1] 1	
			[2] 0	
Description:	Calls 'Copy Command Dataset (CDS)' function. The list of all Command Datasets (CDS) parameters is shown in Section 1.3 of this Parameter List (PLI).			
Example:	Copying of all values from CDS0 to CDS2 can be accomplished by the following procedure: P0809[0] = 0 Copy from CDS0 P0809[1] = 2 Copy to CDS2 P0809[2] = 1 Start copy			
Index:	[0] = Copy from CDS [1] = Copy to CDS [2] = Start copy			
Note:	Start value in index 2 is automatically reset to '0' after execution of function.			
p0810	BI: CDS bit 0 (Hand/Auto) / CDS bit 0			
	Access level: 2	Calculated: -	Data type: U32 / Binary	
	Can be changed: U, T	Scaling: -	Data set: -	
	Min	Max	Factory setting	
	-	-	0	
Description:	Selects command source from which to read Bit 0 for selecting a Command Dataset (CDS). The actual selected CDS is displayed in r0054.15 (CDS bit 0) and r0055.15 (CDS bit 1). The actual active CDS is displayed in r0050.			
Note:	P0811 is also relevant for Command Dataset (CDS) set selection.			
p0811	BI: CDS bit 1 / CDS bit 1			
	Access level: 2	Calculated: -	Data type: U32 / Binary	
	Can be changed: U, T	Scaling: -	Data set: -	
	Min	Max	Factory setting	
	-	-	0	
Description:	Selects command source from which to read Bit 1 for selecting a Command Dataset (see P0810).			
Note:	P0810 is also relevant for Command Dataset (CDS) selection.			

p0819[0...2]	Copy Drive Dataset (DDS) / Copy DDS		
	Access level: 2	Calculated: -	Data type: Unsigned16
	Can be changed: T	Scaling: -	Data set: -
	Min 0	Max 2	Factory setting [0] 0 [1] 1 [2] 0
Description:	Calls 'Copy Drive Dataset (DDS)' function. The list of all Drive Dataset (DDS) parameters is shown in Section 1.3 of the Parameter List (PLI).		
Example:	Copying of all values from DDS0 to DDS2 can be accomplished by the following procedure: P0819[0] = 0 Copy from DDS0 P0819[1] = 2 Copy to DDS2 P0819[2] = 1 Start copy		
Index:	[0] = Copy from DDS [1] = Copy to DDS [2] = Start copy		
Note:	Start value in index 2 is automatically reset to '0' after execution of function.		
p0820	BI: DDS bit 0 / DDS bit 0		
	Access level: 3	Calculated: -	Data type: U32 / Binary
	Can be changed: T	Scaling: -	Data set: -
	Min -	Max -	Factory setting 0
Description:	Selects command source from which to read Bit 0 for selecting a Drive Dataset (DDS). The actual selected Drive Dataset (DDS) is displayed in parameter r0051[0]. The actual active Drive Dataset (DDS) is displayed in parameter r0051[1].		
Note:	P0821 is also relevant for Drive Dataset (DDS) selection.		
p0821	BI: DDS bit 1 / DDS bit 1		
	Access level: 3	Calculated: -	Data type: U32 / Binary
	Can be changed: T	Scaling: -	Data set: -
	Min -	Max -	Factory setting 0
Description:	Selects command source from which Bit 1 for selecting a Drive Dataset is to be read in (see parameter P0820).		
Note:	P0820 is also relevant for Drive Dataset (DDS) selection.		
p0840[0...2]	BI: ON/OFF1 / ON/OFF1		
	Access level: 3	Calculated: -	Data type: U32 / Binary
	Can be changed: T	Scaling: -	Data set: CDS
	Min -	Max -	Factory setting 2090.0
Description:	Allows ON/OFF1 command source to be selected using BICO.		
Dependency:	BICO requires P0700 set to 2 (enable BICO). The default setting (ON right) is digital input 0 (722.0). Alternative source possible only when function of digital input 0 is changed (via P0701) before changing value of P0840.		

p0842[0...2]	BI: ON reverse/OFF1 / ON reverse/OFF1		
	Access level: 3	Calculated: -	Data type: U32 / Binary
	Can be changed: T	Scaling: -	Data set: CDS
	Min	Max	Factory setting
	-	-	0

Description: Allows ON/OFF1 reverse command source to be selected using BICO.
In general a positive frequency setpoint is run up counterclockwise (negative frequency).

p0844[0...2]	BI: 1. OFF2 / 1. OFF2		
	Access level: 3	Calculated: -	Data type: U32 / Binary
	Can be changed: T	Scaling: -	Data set: CDS
	Min	Max	Factory setting
	-	-	2090.1

Description: Defines first source of OFF2 when P0719 = 0 (BICO).
Dependency: If one of the digital inputs is selected for OFF2, the inverter will not run unless the digital input is active.
Note: OFF2 means immediate pulse-disabling; the motor is coasting.
 OFF2 is low-active, i.e. :
 0 = Pulse disabling.
 1 = Operating condition.

p0845[0...2]	BI: 2. OFF2 / 2. OFF2		
	Access level: 3	Calculated: -	Data type: U32 / Binary
	Can be changed: T	Scaling: -	Data set: CDS
	Min	Max	Factory setting
	-	-	1

Description: Defines second source of OFF2.
Dependency: In contrast to P0844 (first source of OFF2), this parameter is always active, independent of P0719 (selection of command and frequency setpoint).
 If one of the digital inputs is selected for OFF2, the inverter will not run unless the digital input is active.
Note: OFF2 means immediate pulse-disabling; the motor is coasting.
 OFF2 is low-active, i.e. :
 0 = Pulse disabling.
 1 = Operating condition.

p0848[0...2]	BI: 1. OFF3 / 1. OFF3		
	Access level: 3	Calculated: -	Data type: U32 / Binary
	Can be changed: T	Scaling: -	Data set: CDS
	Min	Max	Factory setting
	-	-	2090.2

Description: Defines first source of OFF3 when P0719 = 0 (BICO).
Dependency: If one of the digital inputs is selected for OFF3, the inverter will not run unless the digital input is active.
Note: OFF3 means quick ramp-down to 0.
 OFF3 is low-active, i.e.
 0 = Quick ramp-down.
 1 = Operating condition.

p0849[0...2]	BI: 2. OFF3 / 2. OFF3		
	Access level: 3	Calculated: -	Data type: U32 / Binary
	Can be changed: T	Scaling: -	Data set: CDS
	Min	Max	Factory setting
	-	-	1
Description:	Defines second source of OFF3.		
Dependency:	In contrast to P0848 (first source of OFF3), this parameter is always active, independent of P0719 (selection of command and frequency setpoint).		
Note:	If one of the digital inputs is selected for OFF3, the inverter will not run unless the digital input is active. OFF3 means quick ramp-down to 0. OFF3 is low-active, i.e. 0 = Quick ramp-down. 1 = Operating condition.		
p0852[0...2]	BI: Pulse enable / Pulse enable		
	Access level: 3	Calculated: -	Data type: U32 / Binary
	Can be changed: T	Scaling: -	Data set: CDS
	Min	Max	Factory setting
	-	-	2090.3
Description:	Defines source of pulse enable/disable signal.		
Dependency:	Active only when P0719 = 0 (Auto selection of command/setpoint source).		
p0881[0...2]	BI: Quick Stop ON Source 1 / Quick Stop S1		
	Access level: 3	Calculated: -	Data type: U32 / Binary
	Can be changed: T	Scaling: -	Data set: CDS
	Min	Max	Factory setting
	-	-	1
Description:	Allows Quick Stop source 1 command to be selected using BICO. The signal is expected to be active low (default setting p0886 = 2).		
p0882[0...2]	BI: Quick Stop ON Source 2 / Quick Stop S2		
	Access level: 3	Calculated: -	Data type: U32 / Binary
	Can be changed: T	Scaling: -	Data set: CDS
	Min	Max	Factory setting
	-	-	1
Description:	Allows Quick Stop source 2 command to be selected using BICO. The signal is expected to be active low (default setting p0886 = 2).		
p0883[0...2]	BI: Quick Stop Override / QS Override		
	Access level: 3	Calculated: -	Data type: U32 / Binary
	Can be changed: T	Scaling: -	Data set: CDS
	Min	Max	Factory setting
	-	-	2091.6
Description:	Allows Quick Stop override command source to be selected using BICO. The signal is expected to be active high.		

[6] = Recent fault trip --, fault 7
 [7] = Recent fault trip --, fault 8
 [8] = Recent fault trip -1, fault 1

Note: See Chapter "Faults and Warnings".

r0948[0...63]	Fault time / Fault time		
	Access level: 3	Calculated: -	Data type: Unsigned32
	Unit: -	Scaling: -	Data set: -
Description:	Time stamp to indicate when a fault has occurred. P2114 (run-time counter) or P2115 (real time clock) are the possible sources of the time stamp. In case of PROFIdrive Profile 3.1 or higher configuration, P0969 (system run time counter) is used.		
Index:	[0] = Recent fault trip --, fault time 1 [1] = Recent fault trip --, fault time 2 [2] = Recent fault trip --, fault time 3 [3] = Recent fault trip --, fault time 4 [4] = Recent fault trip --, fault time 5 [5] = Recent fault trip --, fault time 6 [6] = Recent fault trip --, fault time 7 [7] = Recent fault trip --, fault time 8 [8] = Recent fault trip -1, fault time 1		
Note:	P2115 can be updated via STARTER, DriveMonitor, etc.		

r0949[0...63]	CO: Fault value / Fault value		
	Access level: 3	Calculated: -	Data type: Unsigned32
	Unit: -	Scaling: -	Data set: -
Description:	Displays drive fault values. It is for service purposes and indicate the type of fault reported. The values are not documented. They are listed in the code where faults are reported.		
Index:	[0] = Recent fault trip --, fault value 1 [1] = Recent fault trip --, fault value 2 [2] = Recent fault trip --, fault value 3 [3] = Recent fault trip --, fault value 4 [4] = Recent fault trip --, fault value 5 [5] = Recent fault trip --, fault value 6 [6] = Recent fault trip --, fault value 7 [7] = Recent fault trip --, fault value 8 [8] = Recent fault trip -1, fault value 1		

p0952	Total number of faults / Total faults		
	Access level: 3	Calculated: -	Data type: Unsigned16
	Can be changed: T	Scaling: -	Data set: -
	Min 0	Max 65535	Factory setting 0
Description:	Displays number of faults stored in P0947 (last fault code).		
Dependency:	Setting 0 resets fault history. (changing to 0 also resets parameter r0948 - fault time).		

r0964[0...6]	Firmware version data / FW version data		
	Access level: 3	Calculated: -	Data type: Unsigned16
	Unit: -	Scaling: -	Data set: -
Description:	Firmware version data.		
Index:	[0] = Company (Siemens = 42) [1] = Product type [2] = Firmware version [3] = Firmware date (year) [4] = Firmware date (day/month)		

[5] = Number of drive objects
[6] = Firmware version

r0965	PROFdrive Profile / PROFdrive Profile				
	Access level: 3	Calculated: -	Data type: Unsigned16		
	Unit: -	Scaling: -	Data set: -		
Description:	Identification for PROFdrive Profile number and version.				
r0967	Control word 1 / Control word 1				
	Access level: 3	Calculated: -	Data type: Unsigned16		
	Unit: -	Scaling: -	Data set: -		
Description:	Displays control word 1.				
Bit field:	Bit	Signal name	1 signal	0 signal	FP
	00	ON/OFF1	Yes	No	-
	01	OFF2: Electrical stop	No	Yes	-
	02	OFF3: Fast stop	No	Yes	-
	03	Pulse enable	Yes	No	-
	04	RFG enable	Yes	No	-
	05	RFG start	Yes	No	-
	06	Setpoint enable	Yes	No	-
	07	Fault acknowledge	Yes	No	-
	08	JOG right	Yes	No	-
	09	JOG left	Yes	No	-
	10	Control from PLC	Yes	No	-
	11	Reverse (setpoint inversion)	Yes	No	-
	13	Motor potentiometer MOP up	Yes	No	-
	14	Motor potentiometer MOP down	Yes	No	-
	15	CDS Bit 0 (Hand/Auto)	Yes	No	-
r0968	Status word 1 / Status word 1				
	Access level: 3	Calculated: -	Data type: Unsigned16		
	Unit: -	Scaling: -	Data set: -		
Description:	Displays active status word of inverter (in binary) and can be used to diagnose which commands are active.				
Bit field:	Bit	Signal name	1 signal	0 signal	FP
	00	Drive ready	Yes	No	-
	01	Drive ready to run	Yes	No	-
	02	Drive running	Yes	No	-
	03	Drive fault active	Yes	No	-
	04	OFF2 active	No	Yes	-
	05	OFF3 active	No	Yes	-
	06	ON inhibit active	Yes	No	-
	07	Drive warning active	Yes	No	-
	08	Deviation setpoint / act. value	No	Yes	-
	09	PZD control	Yes	No	-
	10	f_act >= P1082 (f_max)	Yes	No	-
	11	Warning: Motor current/torque limit	No	Yes	-
	12	Brake open	Yes	No	-
	13	Motor overload	No	Yes	-
	14	Motor runs right	Yes	No	-
	15	Inverter overload	No	Yes	-
p0969	Resetable system run time counter / Rst counter				
	Access level: 3	Calculated: -	Data type: Unsigned32		
	Can be changed: T	Scaling: -	Data set: -		
	Min	Max	Factory setting		
	0	4294967295	0		
Description:	Resetable system run time counter.				

p0970	Factory reset / Factory reset		
	Access level: 1	Calculated: -	Data type: Unsigned16
	Can be changed: -	Scaling: -	Data set: -
	Min 0	Max 1	Factory setting 0
Description:	P0970 = 1 resets all parameters to their default values.		
Value:	0: Disabled 1: Parameter reset		
Dependency:	First set P0010 = 30 (factory settings). Stop drive (i.e. disable all pulses) before you can reset parameters to default values.		
Note:	The following parameters retain their values after a factory reset: <ul style="list-style-type: none"> • r0039 CO: Energy consumption meter [kWh] • P0014 Store mode • P0100 Europe / North America • P2010 USS baud rate • P2011 USS address • P2021 ASI slave address When transferring parameter p0970, the frequency inverter uses its processor to carry-out internal calculations. Communications - both via USS as well as via the Fieldbus - are interrupted for the time that it takes to make these calculations. This can result in the following error messages at the connected SIMATIC S7 control (communications via fieldbus): <ul style="list-style-type: none"> • Parameter fault 30 • Drive fault 70 • Drive fault 75 When using STARTER (USS) to commission the drive system, data cannot be entered while these calculations are being made. The faults can be acknowledged as soon as the calculations have been completed in the frequency inverter. These calculations can take up to one minute to complete.		
p0971	Transfer data from RAM to EEPROM / Transf.RAM->EEPROM		
	Access level: 3	Calculated: -	Data type: Unsigned16
	Can be changed: U, T	Scaling: -	Data set: -
	Min 0	Max 1	Factory setting 0
Description:	Transfers values from RAM to EEPROM when set to 1.		
Value:	0: Disabled 1: Start transfer		
Note:	All values in RAM are transferred to EEPROM. Parameter is automatically reset to 0 (default) after successful transfer. The storage from RAM to EEPROM is accomplished via P0971. The communications are reset, if the transfer was successful. During the reset process communications will be interrupted. This creates the following conditions: <ul style="list-style-type: none"> • PLC (e.g. SIMATIC S7) enters Stop mode • STARTER automatically recovers communications once they are re-established. After completion of the transfer process, the communication between the inverter and the PC-tools (e.g. STARTER) is automatically re-established.		
r0980[0...99]	List of available parameter numbers / Parameter list		
	Access level: 2	Calculated: -	Data type: Unsigned16
	Unit: -	Scaling: -	Data set: -
Description:	Contains 100 parameter numbers index 0 - 99.		
Index:	[0] = Parameter 1 [1] = Parameter 2 [2] = Parameter 3 [3] = Parameter 4		

[4] = Parameter 5
 [5] = Parameter 6
 [6] = Parameter 7
 [7] = Parameter 8
 [8] = Parameter 9
 [9] = Parameter 10

Note: The parameter list array has 2 elements to reduce memory consumption. On each access to an element index 0-99, the individual result is determined dynamically by the 'BeforeAccess' function. The last element contains the number of the following parameter array, 0 indicates end of list

r0981[0...99] List of available parameter numbers / Parameter list

Access level: 2 **Calculated:** - **Data type:** Unsigned16
Unit: - **Scaling:** - **Data set:** -

Description: Contains 100 parameter numbers index 100 - 199.

Index: [0] = Parameter 1
 [1] = Parameter 2
 [2] = Parameter 3
 [3] = Parameter 4
 [4] = Parameter 5
 [5] = Parameter 6
 [6] = Parameter 7
 [7] = Parameter 8
 [8] = Parameter 9
 [9] = Parameter 10

Note: The parameter list array has 2 elements to reduce memory consumption. On each access to an element index 0-99, the individual result is determined dynamically by the 'BeforeAccess' function. The last element contains the number of the following parameter array, 0 indicates end of list

r0982[0...99] List of available parameter numbers / Parameter list

Access level: 2 **Calculated:** - **Data type:** Unsigned16
Unit: - **Scaling:** - **Data set:** -

Description: Contains 100 parameter numbers index 200 - 299.

Index: [0] = Parameter 1
 [1] = Parameter 2
 [2] = Parameter 3
 [3] = Parameter 4
 [4] = Parameter 5
 [5] = Parameter 6
 [6] = Parameter 7
 [7] = Parameter 8
 [8] = Parameter 9
 [9] = Parameter 10

Note: The parameter list array has 2 elements to reduce memory consumption. On each access to an element index 0-99, the individual result is determined dynamically by the 'BeforeAccess' function. The last element contains the number of the following parameter array, 0 indicates end of list

r0983[0...99] List of available parameter numbers / Parameter list

Access level: 2 **Calculated:** - **Data type:** Unsigned16
Unit: - **Scaling:** - **Data set:** -

Description: Contains 100 parameter numbers index 300 - 399.

Index: [0] = Parameter 1
 [1] = Parameter 2
 [2] = Parameter 3
 [3] = Parameter 4
 [4] = Parameter 5
 [5] = Parameter 6
 [6] = Parameter 7
 [7] = Parameter 8

[8] = Parameter 9
[9] = Parameter 10

Note: The parameter list array has 2 elements to reduce memory consumption. On each access to an element index 0-99, the individual result is determined dynamically by the 'BeforeAccess' function. The last element contains the number of the following parameter array, 0 indicates end of list

r0984[0...99] List of available parameter numbers / Parameter list

Access level: 2 **Calculated:** - **Data type:** Unsigned16
Unit: - **Scaling:** - **Data set:** -

Description: Contains 100 parameter numbers index 400 - 499.

Index: [0] = Parameter 1
[1] = Parameter 2
[2] = Parameter 3
[3] = Parameter 4
[4] = Parameter 5
[5] = Parameter 6
[6] = Parameter 7
[7] = Parameter 8
[8] = Parameter 9
[9] = Parameter 10

Note: The parameter list array has 2 elements to reduce memory consumption. On each access to an element index 0-99, the individual result is determined dynamically by the 'BeforeAccess' function. The last element contains the number of the following parameter array, 0 indicates end of list

r0985[0...99] List of available parameter numbers / Parameter list

Access level: 2 **Calculated:** - **Data type:** Unsigned16
Unit: - **Scaling:** - **Data set:** -

Description: Contains 100 parameter numbers index 500 - 599.

Index: [0] = Parameter 1
[1] = Parameter 2
[2] = Parameter 3
[3] = Parameter 4
[4] = Parameter 5
[5] = Parameter 6
[6] = Parameter 7
[7] = Parameter 8
[8] = Parameter 9
[9] = Parameter 10

Note: The parameter list array has 2 elements to reduce memory consumption. On each access to an element index 0-99, the individual result is determined dynamically by the 'BeforeAccess' function. The last element contains the number of the following parameter array, 0 indicates end of list

r0986[0...99] List of available parameter numbers / Parameter list

Access level: 2 **Calculated:** - **Data type:** Unsigned16
Unit: - **Scaling:** - **Data set:** -

Description: Contains 100 parameter numbers index 600 - 699.

Index: [0] = Parameter 1
[1] = Parameter 2
[2] = Parameter 3
[3] = Parameter 4
[4] = Parameter 5
[5] = Parameter 6
[6] = Parameter 7
[7] = Parameter 8
[8] = Parameter 9
[9] = Parameter 10

Note: The parameter list array has 2 elements to reduce memory consumption. On each access to an element index 0-99, the individual result is determined dynamically by the 'BeforeAccess' function. The last element contains the number of the following parameter array, 0 indicates end of list

r0987[0...99] List of available parameter numbers / Paramter list

Access level: 2 **Calculated:** - **Data type:** Unsigned16
Unit: - **Scaling:** - **Data set:** -

Description: Contains 100 parameter numbers index 700 - 799.

Index: [0] = Parameter 1
[1] = Parameter 2
[2] = Parameter 3
[3] = Parameter 4
[4] = Parameter 5
[5] = Parameter 6
[6] = Parameter 7
[7] = Parameter 8
[8] = Parameter 9
[9] = Parameter 10

Note: The parameter list array has 2 elements to reduce memory consumption. On each access to an element index 0-99, the individual result is determined dynamically by the 'BeforeAccess' function. The last element contains the number of the following parameter array, 0 indicates end of list

r0988[0...99] List of available parameter numbers / Paramter list

Access level: 2 **Calculated:** - **Data type:** Unsigned16
Unit: - **Scaling:** - **Data set:** -

Description: Contains 100 parameter numbers index 800 - 899.

Index: [0] = Parameter 1
[1] = Parameter 2
[2] = Parameter 3
[3] = Parameter 4
[4] = Parameter 5
[5] = Parameter 6
[6] = Parameter 7
[7] = Parameter 8
[8] = Parameter 9
[9] = Parameter 10

Note: The parameter list array has 2 elements to reduce memory consumption. On each access to an element index 0-99, the individual result is determined dynamically by the 'BeforeAccess' function. The last element contains the number of the following parameter array, 0 indicates end of list

r0989[0...99] List of available parameter numbers / Paramter list

Access level: 2 **Calculated:** - **Data type:** Unsigned16
Unit: - **Scaling:** - **Data set:** -

Description: Contains 100 parameter numbers index 900 - 999.

Index: [0] = Parameter 1
[1] = Parameter 2
[2] = Parameter 3
[3] = Parameter 4
[4] = Parameter 5
[5] = Parameter 6
[6] = Parameter 7
[7] = Parameter 8
[8] = Parameter 9
[9] = Parameter 10

Note: The parameter list array has 2 elements to reduce memory consumption. On each access to an element index 0-99, the individual result is determined dynamically by the 'BeforeAccess' function. The last element contains the number of the following parameter array, 0 indicates end of list

p1000[0...2] Selection of frequency setpoint / Freq setp. select.			
	Access level: 1	Calculated: -	Data type: Unsigned16
	Can be changed: C(1), T	Scaling: -	Data set: CDS
	Min 0	Max 66	Factory setting 3
Description:	Selects frequency setpoint source. The main setpoint is given by the least significant digit (right-hand position) and the additional setpoint is given by the most significant digit (left-hand position). Single digits denote main setpoints that have no additional setpoint.		
Value:	0: No main setpoint 1: MOP setpoint 2: Analog setpoint 3: Fixed frequency 4: USS on RS232 6: Fieldbus 10: No main setpoint + MOP setpoint 11: MOP setpoint + MOP setpoint 12: Analog setpoint + MOP setpoint 13: Fixed frequency + MOP setpoint 14: USS on RS232 + MOP setpoint 20: No main setpoint + Analog setpoint 21: MOP setpoint + Analog setpoint 22: Analog setpoint + Analog setpoint 23: Fixed frequency + Analog setpoint 24: USS on RS232 + Analog setpoint 26: Fieldbus + Analog setpoint 30: No main setpoint + Fixed frequency 31: MOP setpoint + Fixed frequency 32: Analog setpoint + Fixed frequency 33: Fixed frequency + Fixed frequency 34: USS on RS232 + Fixed frequency 36: Fieldbus + Fixed frequency 40: No main setpoint + USS on RS232 41: MOP setpoint + USS on RS232 42: Analog setpoint + USS on RS232 43: Fixed frequency + USS on RS232 44: USS on RS232 + USS on RS232 46: Fieldbus + USS on RS232 60: No main setpoint + Fieldbus 61: MOP setpoint + Fieldbus 62: Analog setpoint + Fieldbus 63: Fixed frequency + Fieldbus 64: USS on RS232 + Fieldbus 66: Fieldbus + Fieldbus		
Caution:	 Changing this parameter sets (to default) all settings on item selected. These are the following parameters: P1070, P1071, P1075, P1076		
Note:	USS on RS485 is not supported.		

p1001[0...2] Fixed frequency 1 / Fixed frequency 1			
	Access level: 2	Calculated: -	Data type: FloatingPoint32
	Can be changed: U, T	Scaling: -	Data set: DDS
	Min -650.00 [Hz]	Max 650.00 [Hz]	Factory setting 50.00 [Hz]
Description:	Defines fixed frequency setpoint 1. There are 2 types of fixed frequencies:		

1. Direct selection (P1016 = 1):
 - In this mode of operation 1 Fixed Frequency selector (P1020...P1023) selects 1 fixed frequency.
 - If several inputs are active together, the selected frequencies are summed.
E.g.: FF1 + FF2 + FF3 + FF4.
2. Binary coded selection (P1016 = 2):
 - Up to 16 different fixed frequency values can be selected using this method.
 - The fixed frequencies are selected according to FP3210.

Dependency: Select fixed frequency operation (using P1000).
Inverter requires ON command to start in the case of direct selection. Therefore r1025 must be connected to P0840 to start.

Note: Fixed frequencies can be selected using the digital inputs.

p1002[0...2] Fixed frequency 2 / Fixed frequency 2

Access level: 2	Calculated: -	Data type: FloatingPoint32
Can be changed: U, T	Scaling: -	Data set: DDS
Min -650.00 [Hz]	Max 650.00 [Hz]	Factory setting -50.00 [Hz]

Description: Defines fixed frequency setpoint 2.
Note: See parameter P1001 (fixed frequency 1).

p1003[0...2] Fixed frequency 3 / Fixed frequency 3

Access level: 2	Calculated: -	Data type: FloatingPoint32
Can be changed: U, T	Scaling: -	Data set: DDS
Min -650.00 [Hz]	Max 650.00 [Hz]	Factory setting 10.00 [Hz]

Description: Defines fixed frequency setpoint 3.
Note: See parameter P1001 (fixed frequency 1).

p1004[0...2] Fixed frequency 4 / Fixed frequency 4

Access level: 2	Calculated: -	Data type: FloatingPoint32
Can be changed: U, T	Scaling: -	Data set: DDS
Min -650.00 [Hz]	Max 650.00 [Hz]	Factory setting 15.00 [Hz]

Description: Defines fixed frequency setpoint 4.
Note: See parameter P1001 (fixed frequency 1).

p1005[0...2] Fixed frequency 5 / Fixed frequency 5

Access level: 2	Calculated: -	Data type: FloatingPoint32
Can be changed: U, T	Scaling: -	Data set: DDS
Min -650.00 [Hz]	Max 650.00 [Hz]	Factory setting 20.00 [Hz]

Description: Defines fixed frequency setpoint 5.
Note: See parameter P1001 (fixed frequency 1).

p1006[0...2] Fixed frequency 6 / Fixed frequency 6

Access level: 2	Calculated: -	Data type: FloatingPoint32
Can be changed: U, T	Scaling: -	Data set: DDS
Min -650.00 [Hz]	Max 650.00 [Hz]	Factory setting 25.00 [Hz]

Description: Defines fixed frequency setpoint 6.
Note: See parameter P1001 (fixed frequency 1).

p1007[0...2]	Fixed frequency 7 / Fixed frequency 7		
	Access level: 2	Calculated: -	Data type: FloatingPoint32
	Can be changed: U, T	Scaling: -	Data set: DDS
	Min -650.00 [Hz]	Max 650.00 [Hz]	Factory setting 30.00 [Hz]
Description:	Defines fixed frequency setpoint 7.		
Note:	See parameter P1001 (fixed frequency 1).		
p1008[0...2]	Fixed frequency 8 / Fixed frequency 8		
	Access level: 2	Calculated: -	Data type: FloatingPoint32
	Can be changed: U, T	Scaling: -	Data set: DDS
	Min -650.00 [Hz]	Max 650.00 [Hz]	Factory setting 35.00 [Hz]
Description:	Defines fixed frequency setpoint 8.		
Note:	See parameter P1001 (fixed frequency 1).		
p1009[0...2]	Fixed frequency 9 / Fixed frequency 9		
	Access level: 2	Calculated: -	Data type: FloatingPoint32
	Can be changed: U, T	Scaling: -	Data set: DDS
	Min -650.00 [Hz]	Max 650.00 [Hz]	Factory setting 40.00 [Hz]
Description:	Defines fixed frequency setpoint 9.		
Note:	See parameter P1001 (fixed frequency 1).		
p1010[0...2]	Fixed frequency 10 / Fixed frequency 10		
	Access level: 2	Calculated: -	Data type: FloatingPoint32
	Can be changed: U, T	Scaling: -	Data set: DDS
	Min -650.00 [Hz]	Max 650.00 [Hz]	Factory setting 45.00 [Hz]
Description:	Defines fixed frequency setpoint 10.		
Note:	See parameter P1001 (fixed frequency 1).		
p1011[0...2]	Fixed frequency 11 / Fixed frequency 11		
	Access level: 2	Calculated: -	Data type: FloatingPoint32
	Can be changed: U, T	Scaling: -	Data set: DDS
	Min -650.00 [Hz]	Max 650.00 [Hz]	Factory setting 50.00 [Hz]
Description:	Defines fixed frequency setpoint 11.		
Note:	See parameter P1001 (fixed frequency 1).		
p1012[0...2]	Fixed frequency 12 / Fixed frequency 12		
	Access level: 2	Calculated: -	Data type: FloatingPoint32
	Can be changed: U, T	Scaling: -	Data set: DDS
	Min -650.00 [Hz]	Max 650.00 [Hz]	Factory setting 55.00 [Hz]
Description:	Defines fixed frequency setpoint 12.		
Note:	See parameter P1001 (fixed frequency 1).		

p1013[0...2]	Fixed frequency 13 / Fixed frequency 13		
	Access level: 2	Calculated: -	Data type: FloatingPoint32
	Can be changed: U, T	Scaling: -	Data set: DDS
	Min -650.00 [Hz]	Max 650.00 [Hz]	Factory setting 60.00 [Hz]
Description:	Defines fixed frequency setpoint 13.		
Note:	See parameter P1001 (fixed frequency 1).		
p1014[0...2]	Fixed frequency 14 / Fixed frequency 14		
	Access level: 2	Calculated: -	Data type: FloatingPoint32
	Can be changed: U, T	Scaling: -	Data set: DDS
	Min -650.00 [Hz]	Max 650.00 [Hz]	Factory setting 65.00 [Hz]
Description:	Defines fixed frequency setpoint 14.		
Note:	See parameter P1001 (fixed frequency 1).		
p1015[0...2]	Fixed frequency 15 / Fixed frequency 15		
	Access level: 2	Calculated: -	Data type: FloatingPoint32
	Can be changed: U, T	Scaling: -	Data set: DDS
	Min -650.00 [Hz]	Max 650.00 [Hz]	Factory setting 65.00 [Hz]
Description:	Defines fixed frequency setpoint 15.		
Note:	See parameter P1001 (fixed frequency 1).		
p1016[0...2]	Fixed frequency mode / FF mode		
	Access level: 2	Calculated: -	Data type: Unsigned16
	Can be changed: T	Scaling: -	Data set: DDS
	Min 1	Max 2	Factory setting 2
Description:	Fixed frequencies can be selected in two different modes. Parameter P1016 defines the mode.		
Value:	1: Direct selection 2: Binary selection		
Note:	See P1001 (fixed frequency 1) for description of how to use fixed frequencies.		
p1020[0...2]	BI: Fixed freq. selection Bit 0 / FF sel. Bit 0		
	Access level: 3	Calculated: -	Data type: U32 / Binary
	Can be changed: T	Scaling: -	Data set: CDS
	Min -	Max -	Factory setting 2091.0
Description:	Defines origin of fixed frequency selection.		
Dependency:	Accessible only if P0701 - P070x = 99 (function of digital inputs = BICO)		
p1021[0...2]	BI: Fixed freq. selection Bit 1 / FF sel. Bit 1		
	Access level: 3	Calculated: -	Data type: U32 / Binary
	Can be changed: T	Scaling: -	Data set: CDS
	Min -	Max -	Factory setting 2091.1
Description:	Defines origin of fixed frequency selection.		
Dependency:	Accessible only if P0701 - P070x = 99 (function of digital inputs = BICO)		

p1022[0...2]	BI: Fixed freq. selection Bit 2 / FF sel. Bit 2			
	Access level: 3	Calculated: -	Data type: U32 / Binary	
	Can be changed: T	Scaling: -	Data set: CDS	
	Min	Max	Factory setting	
	-	-	2091.2	
Description:	Defines origin of fixed frequency selection.			
Dependency:	Accessible only if P0701 - P070x = 99 (function of digital inputs = BICO)			
p1023[0...2]	BI: Fixed freq. selection Bit 3 / FF sel. Bit 3			
	Access level: 3	Calculated: -	Data type: U32 / Binary	
	Can be changed: T	Scaling: -	Data set: CDS	
	Min	Max	Factory setting	
	-	-	2091.3	
Description:	Defines origin of fixed frequency selection.			
Dependency:	Accessible only if P0701 - P070x = 99 (function of digital inputs = BICO)			
r1024	CO: Act. fixed frequency / Act. FF			
	Access level: 3	Calculated: -	Data type: FloatingPoint32	
	Unit: [Hz]	Scaling: -	Data set: -	
Description:	Displays sum total of selected fixed frequencies.			
r1025.0	BO: Fixed frequency status / FF Status			
	Access level: 3	Calculated: -	Data type: Unsigned16	
	Unit: -	Scaling: -	Data set: -	
Description:	Displays the status of fixed frequencies.			
Bit field:	Bit	Signal name	1 signal	0 signal
	00	Status of FF	Yes	No
				FP
				-
p1031[0...2]	MOP mode / MOP mode			
	Access level: 2	Calculated: -	Data type: Unsigned16	
	Can be changed: U, T	Scaling: -	Data set: DDS	
	Min	Max	Factory setting	
	-	-	0	
Description:	MOP mode specification.			
Bit field:	Bit	Signal name	1 signal	0 signal
	00	Setpoint store activ	Yes	No
	01	No On-state for MOP necessary	Yes	No
				FP
				-
Note:	Defines the operation mode of the motorized potentiometer. See P1040 (setpoint of MOP).			
p1032	Inhibit reverse direction of MOP / Inhib. MOP reverse			
	Access level: 2	Calculated: -	Data type: Unsigned16	
	Can be changed: T	Scaling: -	Data set: -	
	Min	Max	Factory setting	
	0	1	1	
Description:	Inhibits reverse setpoint selection of the MOP.			
Value:	0: Reverse direction is allowed 1: Reverse direction inhibited			
Note:	Setting 0 enables a change of motor direction using the motor potentiometer setpoint (increase/decrease frequency).			

p1035[0...2]	BI: Enable MOP (UP-command) / Enable MOP(UP)		
	Access level: 3	Calculated: -	Data type: U32 / Binary
	Can be changed: T	Scaling: -	Data set: CDS
	Min -	Max -	Factory setting 0
Description:	Defines source for motor potentiometer setpoint increase frequency.		
Notice:	If this command is enabled by short pulses of less than 1 second, the frequency is changed in steps of 0.1 Hz. When the signal is enabled longer than 1 second the ramp generator accelerates with the rate of P1047.		
p1036[0...2]	BI: Enable MOP (DOWN-command) / Enable MOP(DWN)		
	Access level: 3	Calculated: -	Data type: U32 / Binary
	Can be changed: T	Scaling: -	Data set: CDS
	Min -	Max -	Factory setting 0
Description:	Defines source for motor potentiometer setpoint decrease frequency.		
Notice:	If this command is enabled by short pulses of less than 1 second, the frequency is changed in steps of 0.1 Hz. When the signal is enabled longer than 1 second the ramp generator decelerates with the rate of P1048.		
p1040[0...2]	Setpoint of the MOP / MOP setpoint		
	Access level: 2	Calculated: -	Data type: FloatingPoint32
	Can be changed: U, T	Scaling: -	Data set: DDS
	Min -650.00 [Hz]	Max 650.00 [Hz]	Factory setting 5.00 [Hz]
Description:	Determines setpoint for motor potentiometer control (P1000 = 1).		
Dependency:	Motor potentiometer (P1040) must be chosen as main setpoint or additional setpoint (using P1000).		
Note:	<p>If motor potentiometer setpoint is selected either as main setpoint or additional setpoint, the reverse direction will be inhibited by default of P1032 (inhibit reverse direction of MOP).</p> <p>To re-enable reverse direction, set P1032 = 0.</p> <p>The start value gets active (for the MOP output) only at the start of the MOP. The parameter P1031 influences the start value behaviour as follows:</p> <ul style="list-style-type: none"> • P1031=0: P1040 gets immediately active in the OFF-state and when changed in the ON-state, it gets active after the next OFF and ON cycle. • P1031=1: The last MOP output before stop is stored as starting value, since storing is selected, so a change of P1040 while in ON-state has no effect. In OFF-state P1040 can be changed. • P1031=2: The MOP is active every time, so the change of P1040 affects after the next power cycle or a change of P1031 to 0. • P1031=3: The last MOP output before power down is stored as starting value, since the MOP is active independent from the ON-command, a change of P1040 has only effect in the case of a change of P1031. 		

p1041[0...2]	BI: MOP select setpoint automatically/manually / Setp. auto/manu		
	Access level: 3	Calculated: -	Data type: U32 / Binary
	Can be changed: T	Scaling: -	Data set: CDS
	Min -	Max -	Factory setting 0
Description:	Sets the signal source to change over from manual to automatic mode. If using the motorized potentiometer in the manual mode the setpoint is changed using two signals for up and down e.g. P1035 and P1036. If using the automatic mode the setpoint must be interconnected via the connector input (P1042). 0 : manually 1 : automatically		
Notice:	Refer to: P1035, P1036, P1042		
p1042[0...2]	CI: MOP auto setpoint / MOP auto setpoint		
	Access level: 3	Calculated: -	Data type: U32 / Integer32
	Can be changed: T	Scaling: -	Data set: CDS
	Min -	Max -	Factory setting 0
Description:	Sets the signal source for the setpoint of the motorized potentiometer if automatic mode P1041 is selected.		
Notice:	Refer to: P1041		
r1045	CO: MOP input frequency of the RFG / MOP RFG input		
	Access level: 3	Calculated: -	Data type: FloatingPoint32
	Unit: [Hz]	Scaling: -	Data set: -
Description:	Displays the motorized potentiometer setpoint before it passed the MOP RFG.		
p1047[0...2]	MOP ramp-up time of the RFG / MOP ramp-up time		
	Access level: 2	Calculated: -	Data type: FloatingPoint32
	Can be changed: U, T	Scaling: -	Data set: DDS
	Min 0.00 [s]	Max 1000.00 [s]	Factory setting 10.00 [s]
Description:	Sets the ramp-up time for the internal MOP ramp-function generator. The setpoint is changed from zero up to limit defined in P1082 within this time.		
Notice:	Refer to: P1048, P1082		
p1048[0...2]	MOP ramp-down time of the RFG / MOP rampdown time		
	Access level: 2	Calculated: -	Data type: FloatingPoint32
	Can be changed: U, T	Scaling: -	Data set: DDS
	Min 0.00 [s]	Max 1000.00 [s]	Factory setting 10.00 [s]
Description:	Sets the ramp-down time for the internal MOP ramp-function generator. The setpoint is changed from limit defined in P1082 down to zero within this time.		
Notice:	Refer to: P1047, P1082		
r1050	CO: Act. Output freq. of the MOP / MOP outp.freq.		
	Access level: 2	Calculated: -	Data type: FloatingPoint32
	Unit: [Hz]	Scaling: -	Data set: -
Description:	Displays output frequency of motor potentiometer setpoint ([Hz]).		

p1055[0...2]	BI: Enable JOG right / Enable JOG ->		
	Access level: 3	Calculated: -	Data type: U32 / Binary
	Can be changed: T	Scaling: -	Data set: CDS
	Min -	Max -	Factory setting 2090.8
Description:	Defines source of JOG right when P0719 = 0 (Auto selection of command/setpoint source).		
p1056[0...2]	BI: Enable JOG left / Enable JOG <-		
	Access level: 3	Calculated: -	Data type: U32 / Binary
	Can be changed: T	Scaling: -	Data set: CDS
	Min -	Max -	Factory setting 2090.9
Description:	Defines source of JOG left when P0719 = 0 (Auto selection of command/setpoint source).		
p1057	JOG Enable / JOG Enable		
	Access level: 3	Calculated: -	Data type: Unsigned16
	Can be changed: T	Scaling: -	Data set: -
	Min 0000 bin	Max 0001 bin	Factory setting 0001 bin
Description:	While JOG Enable is '0' Jogging (p1056 and p1055) is disabled. When '1' Jogging is enabled.		
p1058[0...2]	JOG frequency / JOG frequency		
	Access level: 2	Calculated: -	Data type: FloatingPoint32
	Can be changed: U, T	Scaling: -	Data set: DDS
	Min 0.00 [Hz]	Max 650.00 [Hz]	Factory setting 5.00 [Hz]
Description:	Jogging increases the motor speed by small amounts. The JOG mode allows the operator to perform a specific number of revolutions and position the rotor manually. The JOG buttons on OP use a non-latching switch on one of the digital inputs to control the motor speed. While the JOG button is pressed, parameter P1058 determines the frequency at which the inverter will run. The motor speed is increased as long as 'JOG left' or 'JOG right' are selected and until the left or right JOG frequency is reached.		
Dependency:	P1060 and P1061 set up and down ramp times respectively for jogging. Rounding times (P1130 - P1133), rounding type (P1134) and P2167 will also have influence on the JOG ramp.		
p1059[0...2]	JOG frequency left / JOG frequency <-		
	Access level: 2	Calculated: -	Data type: FloatingPoint32
	Can be changed: U, T	Scaling: -	Data set: DDS
	Min 0.00 [Hz]	Max 650.00 [Hz]	Factory setting 5.00 [Hz]
Description:	While JOG left is selected, this parameter determines the frequency at which the inverter will run.		
Dependency:	P1060 and P1061 set up and down ramp times respectively for jogging.		
p1060[0...2]	JOG ramp-up time / JOG ramp-up time		
	Access level: 2	Calculated: -	Data type: FloatingPoint32
	Can be changed: U, T	Scaling: -	Data set: DDS
	Min 0.00 [s]	Max 650.00 [s]	Factory setting 10.00 [s]
Description:	Sets jog ramp-up time. This is the time used while jogging is active.		

Notice: Ramp times will be used as follows:

- P1060 / P1061 : JOG mode is active
- P1120 / P1121 : Normal mode (ON/OFF) is active
- P1060 / P1061 : Normal mode (ON/OFF) and P1124 is active

The rounding of P1130 - P1133 also applies to the JOG ramping.

p1061[0...2] JOG ramp-down time / JOG ramp-down time

Access level: 2	Calculated: -	Data type: FloatingPoint32
Can be changed: U, T	Scaling: -	Data set: DDS
Min 0.00 [s]	Max 650.00 [s]	Factory setting 10.00 [s]

Description: Sets ramp-down time.
This is the time used while jogging is active.

Notice: Ramp times will be used as follows:

- P1060 / P1061 : JOG mode is active
- P1120 / P1121 : Normal mode (ON/OFF) is active
- P1060 / P1061 : Normal mode (ON/OFF) and P1124 is active

p1070[0...2] CI: Main setpoint / Main setpoint

Access level: 3	Calculated: -	Data type: U32 / Integer32
Can be changed: T	Scaling: -	Data set: CDS
Min -	Max -	Factory setting 1024[0]

Description: Defines source of main setpoint.

p1071[0...2] CI: Main setpoint scaling / Main setp scal

Access level: 3	Calculated: -	Data type: U32 / Integer16
Can be changed: T	Scaling: 4000H	Data set: CDS
Min -	Max -	Factory setting 1

Description: Defines source of the main setpoint scaling.

p1074[0...2] BI: Disable additional setpoint / Disab.add.setp

Access level: 3	Calculated: -	Data type: U32 / Binary
Can be changed: U, T	Scaling: -	Data set: CDS
Min -	Max -	Factory setting 0

Description: Disables additional setpoint

p1075[0...2] CI: Additional setpoint / Add. setpoint

Access level: 3	Calculated: -	Data type: U32 / Integer32
Can be changed: T	Scaling: -	Data set: CDS
Min -	Max -	Factory setting 0

Description: Defines source of the additional setpoint (to be added to main setpoint).

p1076[0...2]	CI: Additional setpoint scaling / Add. setp.scal		
	Access level: 3	Calculated: -	Data type: U32 / Integer16
	Can be changed: T	Scaling: 4000H	Data set: CDS
	Min -	Max -	Factory setting [0] 1 [1] 0 [2] 1
Description:	Defines source of scaling for additional setpoint (to be added to main setpoint).		
r1078	CO: Total frequency setpoint / Tot. freq.setp		
	Access level: 3	Calculated: -	Data type: FloatingPoint32
	Unit: [Hz]	Scaling: -	Data set: -
Description:	Displays sum of main and additional setpoints in [Hz].		
r1079	CO: Selected frequency setpoint / Sel. freq.setp		
	Access level: 3	Calculated: -	Data type: FloatingPoint32
	Unit: [Hz]	Scaling: -	Data set: -
Description:	Displays selected frequency setpoint. Following frequency setpoints are displayed: <ul style="list-style-type: none"> • r1078 Total frequency setpoint • P1058 JOG frequency right • P1059 JOG frequency left 		
Dependency:	P1055 (BI: Enable JOG right) or P1056 (BI: Enable JOG left) define command source of JOG right or JOG left respectively.		
Note:	P1055 = 0 and P1056 = 0 ==> Total frequency setpoint is selected.		
p1080[0...2]	Min. frequency / Min. frequency		
	Access level: 1	Calculated: -	Data type: FloatingPoint32
	Can be changed: C(1), U, T	Scaling: -	Data set: DDS
	Min 0.00 [Hz]	Max 650.00 [Hz]	Factory setting 0.00 [Hz]
Description:	Sets minimum motor frequency [Hz] at which motor will run irrespective of frequency setpoint. The minimum frequency P1080 represents a masking frequency of 0 Hz for all frequency target value sources e.g. AI, MOP, FF, USS with the exception of the JOG target value source (analogous to P1091). Thus the frequency band +/-P1080 is run through in optimum time by means of the acceleration/deceleration ramps. Dwelling in the frequency band is not possible. Furthermore, an overshoot of the actual frequency f_{act} upper min. frequency P1080 is output by the signal function $ f_{act} > f_{min}$.		
Note:	Value set here is valid both for clockwise and for anticlockwise rotation. Under certain conditions (e.g. ramping, current limiting), motor can run below minimum frequency.		

p1082[0...2]**Max. frequency / Max. frequency****Access level:** 1**Calculated:** -**Data type:** FloatingPoint32**Can be changed:** C(1), T**Scaling:** -**Data set:** DDS**Min**

0.00 [Hz]

Max

550.00 [Hz]

Factory setting

50.00 [Hz]

Description:

Sets maximum motor frequency [Hz] at which motor will run irrespective of the frequency setpoint.

The value set here is valid for both clockwise and anticlockwise rotation.

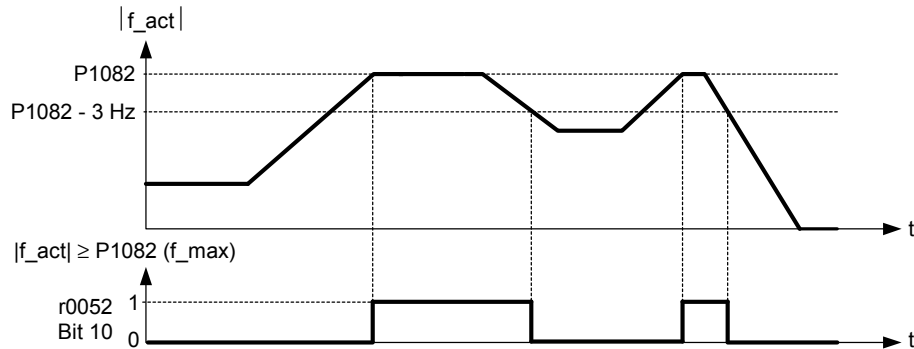
Furthermore, the monitoring function $|f_{act}| \geq P1082$ (r0052 Bit10, see example below) is affected by this parameter.**Example:****Dependency:**The maximum value of P1082 also depends on the nominal frequency: $\text{Max. P1082} = \min(15 \cdot P0310, 650 \text{ Hz})$.

As consequence P1082 can be affected if P0310 is changed to a smaller value.

The maximum frequency and the pulse frequency depending on each other. The maximum frequency affects the pulse frequency according to the following table.

		p1800			
		2 kHz	4 kHz	6 kHz	8 - 16 kHz
f_{max}	p1082	0 - 133.3 Hz	0 - 266.6 Hz	0 - 400 Hz	0 - 650 Hz

Example:

If P1082 is set to 350 Hz a pulse frequency from at least 6 kHz is necessary. If P1800 is smaller than 6 kHz the parameter is changed P1800 = 6 kHz.

The maximum output frequency of inverter can be exceeded if one of the following is active:

- p1335 \neq 0 (Slip compensation active) :

$$f_{max}(p1335) = f_{max} + f_{slip,max} = p1082 + \frac{p1336}{100} \cdot \frac{r0330}{100} \cdot p0310$$

- p1200 \neq 0 (Flying restart active) :

$$f_{max}(p1200) = f_{max} + 2 \cdot f_{slip,nom} = p1082 + 2 \cdot \frac{r0330}{100} \cdot p0310$$

Note:

When using the setpoint source

- Analog Input
- USS

the setpoint frequency (in Hz) is cyclically calculated using

- a percentage value (e.g. for the analog input r0754)
- a hexadecimal value (e.g. for the USS r2018[1])
- and the reference frequency P2000.

If for example P1082 = 80 Hz, P2000 = 50 Hz and the analog input is parameterised with P0757 = 0 V, P0758 = 0 %, P0759 = 10 V, P0760 = 100 %, a setpoint frequency of 50 Hz will be applied at 10 V of the analog input.

When Quick Commissioning is carried out P2000 is changed as follows: P2000 = P1082.

r1084	Resultant max. frequency / Resultant max freq		
	Access level: 3	Calculated: -	Data type: FloatingPoint32
	Unit: [Hz]	Scaling: -	Data set: -
Description:	Displays resultant maximum frequency. p1300 < 20 : p1800 <= 6 kHz --> r1084 = min(p1082, p1800/15, 650.00) p1800 >= 8 kHz --> r1084 = min(p1082, 650.00)		
p1091[0...2]	Skip frequency / Skip frequency		
	Access level: 3	Calculated: -	Data type: FloatingPoint32
	Can be changed: U, T	Scaling: -	Data set: DDS
	Min 0.00 [Hz]	Max 650.00 [Hz]	Factory setting 0.00 [Hz]
Description:	Defines skip frequency 1 which avoids effects of mechanical resonance and suppresses frequencies within +/- P1101 (skip frequency bandwidth).		
Notice:	Stationary operation is not possible within the suppressed frequency range; the range is merely passed through (on the ramp). For example, if P1091 = 10 Hz and P1101 = 2 Hz, it is not possible to operate continuously between 10 Hz +/- 2 Hz (i.e. between 8 and 12 Hz).		
Note:	The function is disabled if P1091 = 0.		
p1092[0...2]	Skip frequency 2 / Skip frequency 2		
	Access level: 3	Calculated: -	Data type: FloatingPoint32
	Can be changed: U, T	Scaling: -	Data set: DDS
	Min 0.00 [Hz]	Max 650.00 [Hz]	Factory setting 0.00 [Hz]
Description:	Defines skip frequency 2 which avoids effects of mechanical resonance and suppresses frequencies within +/- P1101 (skip frequency bandwidth).		
Note:	See P1091 (skip frequency 1).		
p1093[0...2]	Skip frequency 3 / Skip frequency 3		
	Access level: 3	Calculated: -	Data type: FloatingPoint32
	Can be changed: U, T	Scaling: -	Data set: DDS
	Min 0.00 [Hz]	Max 650.00 [Hz]	Factory setting 0.00 [Hz]
Description:	Defines skip frequency 3 which avoids effects of mechanical resonance and suppresses frequencies within +/- P1101 (skip frequency bandwidth).		
Note:	See P1091 (skip frequency 1).		
p1094[0...2]	Skip frequency 4 / Skip frequency 4		
	Access level: 3	Calculated: -	Data type: FloatingPoint32
	Can be changed: U, T	Scaling: -	Data set: DDS
	Min 0.00 [Hz]	Max 650.00 [Hz]	Factory setting 0.00 [Hz]
Description:	Defines skip frequency 4 which avoids effects of mechanical resonance and suppresses frequencies within +/- P1101 (skip frequency bandwidth).		
Note:	See P1091 (skip frequency 1).		

p1101[0...2]	Skip frequency bandwidth / Skipfreq bandwidth		
	Access level: 3	Calculated: -	Data type: FloatingPoint32
	Can be changed: U, T	Scaling: -	Data set: DDS
	Min 0.00 [Hz]	Max 10.00 [Hz]	Factory setting 2.00 [Hz]
Description:	Delivers frequency bandwidth to be applied to skip frequencies (in [Hz]).		
Note:	See P1091 (skip frequency 1).		
p1110[0...2]	BI: Inhibit neg. freq. setpoint / Inh. neg. setp		
	Access level: 3	Calculated: -	Data type: U32 / Binary
	Can be changed: T	Scaling: -	Data set: CDS
	Min -	Max -	Factory setting 0
Description:	This parameter suppresses negative setpoints. Therefore, modification of the motor direction is inhibited to the setpoint channel. If a min. frequency (P1080) and a negative setpoint are given, the motor is accelerated by a positive value in relationship to the min. frequency.		
p1113[0...2]	BI: Reverse / Reverse		
	Access level: 3	Calculated: -	Data type: U32 / Binary
	Can be changed: T	Scaling: -	Data set: CDS
	Min -	Max -	Factory setting 2090.11
Description:	Defines source of reverse command used when P0719 = 0 (Auto selection of command/setpoint source).		
r1114	CO: Freq. setp. after dir. ctrl. / Setp<-dir.ctrl.		
	Access level: 3	Calculated: -	Data type: FloatingPoint32
	Unit: [Hz]	Scaling: -	Data set: -
Description:	Displays setpoint frequency after change of direction.		
r1119	CO: Freq. setpoint before RFG / Setp before RFG		
	Access level: 3	Calculated: -	Data type: FloatingPoint32
	Unit: [Hz]	Scaling: -	Data set: -
Description:	Displays frequency setpoint at the input to the ramp function generator after modification by other functions, e.g.: <ul style="list-style-type: none"> • P1110 BI: Inhibit neg. freq. setpoint, • P1091 - P1094 skip frequencies, • P1080 min. frequency, • P1082 max. frequency, This value is available filtered (r0020) and unfiltered (r1119).		
p1120[0...2]	Ramp-up time / Ramp-up time		
	Access level: 1	Calculated: -	Data type: FloatingPoint32
	Can be changed: C(1), U, T	Scaling: -	Data set: DDS
	Min 0.00 [s]	Max 650.00 [s]	Factory setting 10.00 [s]
Description:	Time taken for motor to accelerate from standstill up to maximum motor frequency (P1082) when no rounding is used. Setting the ramp-up time too short can cause the inverter to trip (overcurrent F0001).		
Dependency:	Rounding times (P1130 - P1133) and rounding type (P1134) will also have influence on the ramp.		

Notice: Ramp times will be used as follows:

- P1060 / P1061 : JOG mode is active
- P1120 / P1121 : Normal mode (ON/OFF) is active
- P1060 / P1061 : Normal mode (ON/OFF) and P1124 is active

Note: If an external frequency setpoint with set ramp rates is used (e.g. from a PLC), the best way to achieve optimum drive performance is to set ramp times in P1120 and P1121 slightly shorter than those of the PLC. Changes to P1120 will be immediately effective.

p1121[0...2]	Ramp-down time / Ramp-down time		
	Access level: 1	Calculated: -	Data type: FloatingPoint32
	Can be changed: C(1), U, T	Scaling: -	Data set: DDS
	Min 0.00 [s]	Max 650.00 [s]	Factory setting 10.00 [s]
Description:	Time taken for motor to decelerate from maximum motor frequency (P1082) down to standstill when no rounding is used.		
Notice:	Setting the ramp-down time too short can cause the inverter to trip (overcurrent F0001 / overvoltage F0002). Ramp times will be used as follows:		
	<ul style="list-style-type: none"> • P1060 / P1061 : JOG mode is active • P1120 / P1121 : Normal mode (ON/OFF) is active • P1060 / P1061 : Normal mode (ON/OFF) and P1124 is active 		
Note:	Changes to P1121 will be immediately effective.		

p1124[0...2]	BI: Enable JOG ramp times / Enable JOG ramp		
	Access level: 3	Calculated: -	Data type: U32 / Binary
	Can be changed: T	Scaling: -	Data set: CDS
	Min -	Max -	Factory setting 0
Description:	Defines source for switching between jog ramp times (P1060, P1061) and normal ramp times (P1120, P1121) as applied to the RFG. This parameter is valid for normal mode (ON/OFF) only.		
Notice:	P1124 does not have any impact when JOG mode is selected. In this case, jog ramp times (P1060, P1061) will be used all the time. Ramp times will be used as follows:		
	<ul style="list-style-type: none"> • P1060 / P1061 : JOG mode is active • P1120 / P1121 : Normal mode (ON/OFF) is active • P1060 / P1061 : Normal mode (ON/OFF) and P1124 is active 		

p1130[0...2]	Ramp-up initial rounding time / Ramp-up ini. Trnd		
	Access level: 2	Calculated: -	Data type: FloatingPoint32
	Can be changed: U, T	Scaling: -	Data set: DDS
	Min 0.00 [s]	Max 40.00 [s]	Factory setting 0.00 [s]
Description:	Defines rounding time in seconds at start of ramp-up.		
Notice:	Rounding times are recommended, since they prevent an abrupt response, thus avoiding detrimental effects on the mechanics. Rounding times are not recommended when analog inputs are used, since they would result in overshoot/under-shoot in the inverter response.		
Note:	If short or zero ramp times (P1120, P1121 < P1130, P1131, P1132, P1133) are set, the total ramp up time (t _{up}) or ramp down time (t _{down}) will not depend on P1130.		

p1131[0...2]	Ramp-up final rounding time / Ramp-up final Trnd		
	Access level: 2	Calculated: -	Data type: FloatingPoint32
	Can be changed: U, T	Scaling: -	Data set: DDS
	Min 0.00 [s]	Max 40.00 [s]	Factory setting 0.00 [s]
Description:	Defines rounding time at end of ramp-up.		
Notice:	Rounding times are not recommended when analog inputs are used, since they would result in overshoot/undershoot in the inverter response.		
Note:	Rounding times are recommended, since they prevent an abrupt response, thus avoiding detrimental effects on the mechanics.		
p1132[0...2]	Ramp-down initial rounding time / Ramp-dwn ini. Trnd		
	Access level: 2	Calculated: -	Data type: FloatingPoint32
	Can be changed: U, T	Scaling: -	Data set: DDS
	Min 0.00 [s]	Max 40.00 [s]	Factory setting 0.00 [s]
Description:	Defines rounding time at start of ramp-down.		
Notice:	Rounding times are not recommended when analog inputs are used, since they would result in overshoot/undershoot in the inverter response.		
Note:	Rounding times are recommended, since they prevent an abrupt response, thus avoiding detrimental effects on the mechanics.		
p1133[0...2]	Ramp-down final rounding time / Ramp-dwn fin. Trnd		
	Access level: 2	Calculated: -	Data type: FloatingPoint32
	Can be changed: U, T	Scaling: -	Data set: DDS
	Min 0.00 [s]	Max 40.00 [s]	Factory setting 0.00 [s]
Description:	Defines rounding time at end of ramp-down.		
Notice:	Rounding times are not recommended when analog inputs are used, since they would result in overshoot/undershoot in the inverter response.		
Note:	Rounding times are recommended, since they prevent an abrupt response, thus avoiding detrimental effects on the mechanics.		
p1134[0...2]	Rounding type / Rounding type		
	Access level: 2	Calculated: -	Data type: Unsigned16
	Can be changed: U, T	Scaling: -	Data set: DDS
	Min 0	Max 1	Factory setting 0
Description:	Defines the smoothing which is active by setpoint modifications during acceleration or deceleration (e.g. new setpoint, OFF1, OFF3, REV). This smoothing is applied, if the motor is ramped-up or ramped-down and		
	<ul style="list-style-type: none"> • P1134 = 0, • P1132 > 0, P1133 > 0 and • the setpoint is not yet reached. 		
Value:	0: Continuous smoothing 1: Discontinuous smoothing		
Dependency:	Effect only when P1130 (Ramp-up initial rounding time) or P1131 (Ramp-up final rounding time) or P1132 (Ramp-down initial rounding time) or P1133 (Ramp-down final rounding time) > 0 s.		

p1135[0...2]	OFF3 ramp-down time / OFF3 ramp-dwn time		
	Access level: 2	Calculated: -	Data type: FloatingPoint32
	Can be changed: C(1), U, T	Scaling: -	Data set: DDS
	Min 0.00 [s]	Max 650.00 [s]	Factory setting 5.00 [s]
Description:	Defines ramp-down time from maximum frequency to standstill for OFF3 command. Settings in P1130 and P1134 will have no effect on OFF3 ramp-down characteristic. An initial ramp-down rounding time of approximately 10% of P1135 is however included. For the total OFF3 ramp-down time: $t_{down,OFF3} = f(p1134) = 1.1 * p1135 * ((f_2) / p1082)$		
Note:	This time may be exceeded if the VDC_max. level is reached.		
p1140[0...2]	BI: RFG enable / RFG enable		
	Access level: 3	Calculated: -	Data type: U32 / Binary
	Can be changed: T	Scaling: -	Data set: CDS
	Min -	Max -	Factory setting 2090.4
Description:	Defines command source of RFG enable command (RFG: ramp function generator). If binary input is equal to zero then the RFG output will be set immediately to 0.		
p1141[0...2]	BI: RFG start / RFG start		
	Access level: 3	Calculated: -	Data type: U32 / Binary
	Can be changed: T	Scaling: -	Data set: CDS
	Min -	Max -	Factory setting 2090.5
Description:	Defines command source of RFG start command (RFG: ramp function generator). If binary input is equal to zero then the RFG output is held at its present value.		
p1142[0...2]	BI: RFG enable setpoint / RFG enable setp		
	Access level: 3	Calculated: -	Data type: U32 / Binary
	Can be changed: T	Scaling: -	Data set: CDS
	Min -	Max -	Factory setting 2090.6
Description:	Defines command source of RFG enable setpoint command (RFG: ramp function generator). If binary input is equal to zero then the RFG input will be set to zero and the RFG output will ramp-down to zero.		
r1170	CO: Frequency setpoint after RFG / Setp. after RFG		
	Access level: 3	Calculated: -	Data type: FloatingPoint32
	Unit: [Hz]	Scaling: -	Data set: -
Description:	Displays overall frequency setpoint after ramp generator.		
p1200	Flying start / Flying start		
	Access level: 2	Calculated: -	Data type: Unsigned16
	Can be changed: C, U, T	Scaling: -	Data set: -
	Min 0	Max 6	Factory setting 0
Description:	Starts inverter onto a spinning motor by rapidly changing the output frequency of the inverter until the actual motor speed has been found. Then, the motor runs up to setpoint using the normal ramp time.		
Value:	0: Flying start disabled 1: Flying start always active, start --> setpoint 2: Flying start active if power on, fault, OFF2, start --> setp. 3: Flying start active if fault, OFF2, start --> setpoint		

- 4: Flying start always active, only --> setpoint
 5: Flying start active if power on, fault, OFF2, only --> setp.
 6: Flying start active if fault, OFF2, only --> setpoint

Notice: Flying start must be used in cases where the motor may still be turning (e.g. after a short mains break) or can be driven by the load. Otherwise, overcurrent trips will occur.

Note: Useful for motors with high inertia loads.
 Settings 1 to 3 search in both directions.
 Settings 4 to 6 search only in direction of setpoint.

p1202[0...2] Motor-current: Flying start / Mot. cur: Flystart

Access level: 3 **Calculated:** - **Data type:** Unsigned16
Can be changed: C, U, T **Scaling:** - **Data set:** DDS
Min **Max** **Factory setting**
 10 [%] 200 [%] 100 [%]

Description: Defines search current used for flying start.
 Value is in [%] based on rated motor current (P0305).

Note: Reducing the search current may improve performance for flying start if the inertia of the system is not very high.

p1203[0...2] Search rate: Flying start / SrchRate: Flystart

Access level: 3 **Calculated:** - **Data type:** Unsigned16
Can be changed: C, U, T **Scaling:** - **Data set:** DDS
Min **Max** **Factory setting**
 10 [%] 200 [%] 100 [%]

Description: Sets factor (in V/f mode only) by which the output frequency changes during flying start to synchronize with turning motor.

This value is entered in [%]. It defines the reciprocal initial gradient in the search sequence.

Parameter P1203 influences the time taken to search for the motor frequency.

Example: For a motor with 50 Hz, 1350 rpm, 100 % would produce a maximum search time of 600 ms.

Note: A higher value produces a flatter gradient and thus a longer search time.
 A lower value has the opposite effect.

r1204 Status word: Flying start V/f / Stat: Flystart V/f

Access level: 4 **Calculated:** - **Data type:** Unsigned16
Unit: - **Scaling:** - **Data set:** -

Description: Bit parameter for checking and monitoring states during search, if V/f control mode is selected (P1300 < 20).

Bit field:	Bit	Signal name	1 signal	0 signal	FP
	00	Current applied	Yes	No	-
	01	Current could not be applied	Yes	No	-
	02	Voltage reduced	Yes	No	-
	03	Slope-filter started	Yes	No	-
	04	Current less threshold	Yes	No	-
	05	Current-minimum	Yes	No	-
	07	Speed could not be found	Yes	No	-

p1210 Automatic restart / Automatic restart

Access level: 2 **Calculated:** - **Data type:** Unsigned16
Can be changed: C, U, T **Scaling:** - **Data set:** -
Min **Max** **Factory setting**
 0 6 1

Description: Configures automatic restart function

Value:
 0: Disabled
 1: Trip reset after power on, P1211 disabled
 2: Restart after mains blackout, P1211 disabled
 3: Restart after mains brownout or fault, P1211 enabled

- 4: Restart after mains brownout, P1211 enabled
 5: Restart after mains blackout and fault, P1211 disabled
 6: Restart after mains brown- /blackout or fault, P1211 enabled

Dependency:

Automatic restart requires constant ON command via a digital input wire link.

Caution:

P1210 > 2 can cause the motor to restart automatically without toggling the ON command !

**Notice:**

A "mains brownout" is a very short mains break, where the DC link has not fully collapsed before the power is re-applied.

A "mains blackout" is a long mains break, where the DC link has fully collapsed before the power is re-applied.

"Delay Time" is the time between attempts of quitting fault. The "Delay Time" of first attempt is 1 second, then it will be doubled every next attempt.

The "Number of Restart Attempts" can be set in P1211. This is the number of restarts the inverter will try to quit fault.

When faults are quit and after 4 seconds of no fault condition, "Number of Restart Attempts" will be reset to P1211 and "Delay Time" will be reset to 1 second.

P1210 = 0:

Automatic restart is disabled.

P1210 = 1:

The inverter will acknowledge (reset) faults i.e. it will reset a fault when the is re-applied. This means the inverter must be fully powered down, a brownout is not sufficed. The inverter will not run until the ON command has been toggled.

P1210 = 2:

The inverter will acknowledge the fault F0003 at power on after blackout and restarts the drive. It is necessary that the ON command is wired via a digital input (DI).

P1210 = 3:

For these settings it is fundamental that the drive only restarts if it has been in a RUN state at the time of the faults (F0003, etc.). The inverter will acknowledge the fault and restarts the drive after a blackout or brownout. It is necessary that the ON command is wired via a digital input (DI).

P1210 = 4:

For these settings it is fundamental that the drive only restarts if it has been in a RUN state at the time of the fault (F0003). The inverter will acknowledge the fault and restarts the drive after a blackout or brownout. It is necessary that the ON command is wired via a digital input (DI).

P1210 = 5:

The inverter will acknowledge the faults F0003 etc. at power on after blackout and restarts the drive. It is necessary that the ON command is wired via a digital input (DI).

P1210 = 6:

The inverter will acknowledge the faults (F0003 etc.) at power on after blackout or brownout and restarts the drive. It is necessary that the ON command is wired via a digital input (DI). Setting 6 causes the motor to restart immediately.

Flying start must be used in cases where the motor may still be turning (e.g. after a short mains break) or can be driven by the load (P1200).

p1211**Number of restart attempts / Restart attempts**

Access level: 3

Calculated: -

Data type: Unsigned16

Can be changed: C, U, T

Scaling: -

Data set: -

Min

Max

Factory setting

0

10

3

Description:

Specifies number of times inverter will attempt to restart if automatic restart P1210 is activated.

p1215	Holding brake enable / MHB enable	Access level: 2 Can be changed: C, T	Calculated: - Scaling: -	Data type: Unsigned16 Data set: -
		Min 0	Max 2	Factory setting 0
Description:	Enables/disables holding brake function. The motor holding brake (MHB) is controlled via status word 1 r0052 Bit12. This signal can be issued via: <ul style="list-style-type: none"> status word of the serial interface (e.g. USS) 			
Value:	0: Motor holding brake disabled 1: Motor holding brake enabled 2: Motor holding brake with voltage boost enabled			
Caution:	It is not permissible to use the motor holding brake as working brake, as it is generally only designed for a limited number of emergency braking operations.			
				
p1216	Holding brake release delay / MHB release delay	Access level: 2 Can be changed: C, T	Calculated: - Scaling: -	Data type: FloatingPoint32 Data set: -
		Min 0.0 [s]	Max 20.0 [s]	Factory setting 1.0 [s]
Description:	Defines period during which inverter runs at min. frequency P1080 before ramping up.			
p1217	Holding time after ramp down / Thold. <- ramp-dwn	Access level: 2 Can be changed: C, T	Calculated: - Scaling: -	Data type: FloatingPoint32 Data set: -
		Min 0.0 [s]	Max 20.0 [s]	Factory setting 1.0 [s]
Description:	Defines time for which inverter runs at minimum frequency (P1080) after ramping down.			
Note:	If P1217 > P1227, parameter P1227 will take precedence.			
p1218[0...2]	BI: MHB override / MHB override	Access level: 3 Can be changed: U, T	Calculated: - Scaling: -	Data type: U32 / Binary Data set: CDS
		Min -	Max -	Factory setting 0
Description:	Enables the MHB output to be overridden, allowing the brake to be opened under separate control.			
p1227[0...2]	Zero speed detection monitoring time / Zero speed time	Access level: 2 Can be changed: U, T	Calculated: - Scaling: -	Data type: FloatingPoint32 Data set: DDS
		Min 0.0 [s]	Max 300.0 [s]	Factory setting 4.0 [s]
Description:	Sets the monitoring time for the standstill identification. When braking with OFF1 or OFF3, standstill is identified after this time has expired, after the setpoint speed has fallen below P2167. After this, the braking signal is started, the system waits for the closing time and then the pulses are cancelled.			
Note:	P1227 = 300.0 : function is deactivated P1227 = 0.0 : pulses are locked immediately If P1217 > P1227, parameter P1227 will take precedence.			

p1230[0...2]	BI: Enable DC braking / Enable DC brk.		
	Access level: 3	Calculated: -	Data type: U32 / Binary
	Can be changed: U, T	Scaling: -	Data set: CDS
	Min -	Max -	Factory setting 0
Description:	<p>Enables DC braking via a signal applied from an external source. Function remains active while external input signal is active. DC braking causes the motor to stop rapidly by applying a DC braking current (current applied also holds shaft stationary). When the DC braking signal is applied, the inverter output pulses are blocked and the DC current is not applied until the motor has been sufficiently demagnetized. This delay time is set in P0347 (demagnetization time). If this delay is too short, overcurrent trips can occur. The level of DC braking is set in P1232 (DC braking current - relative to the rated motor current) which is set to 100 % by default.</p>		
Caution:	<p>With the DC braking, the kinetic energy of the motor is converted into heat in the motor. The drive could overheat if it remains in this status for an excessive period of time ! DC braking is not possible when using a synchronous motor (i.e. P0300 = 2).</p>		



p1232[0...2]	DC braking current / DC braking current		
	Access level: 2	Calculated: -	Data type: Unsigned16
	Can be changed: C, U, T	Scaling: -	Data set: DDS
	Min 0 [%]	Max 250 [%]	Factory setting 100 [%]
Description:	<p>Defines level of DC current in [%] relative to rated motor current (P0305). The DC braking can be issued observing the following dependencies:</p> <ul style="list-style-type: none"> • OFF1 / OFF3 ==> see P1233 • BICO ==> see P1230 		

p1233[0...2]	Duration of DC braking / DC brak. duration		
	Access level: 2	Calculated: -	Data type: FloatingPoint32
	Can be changed: C, U, T	Scaling: -	Data set: DDS
	Min 0.00 [s]	Max 250.00 [s]	Factory setting 0.00 [s]
Description:	<p>Defines duration for which DC braking is active following an OFF1 or OFF3 command. When an OFF1 or OFF3 command is received by the drive, the output frequency starts to ramp to 0 Hz. When the output frequency reaches the value set in P1234, the drive injects a DC braking current P1232 for the time duration set in P1233.</p>		
Caution:	<p>With the DC braking, the kinetic energy of the motor is converted into heat in the motor. The drive could overheat if it remains in this status for an excessive period of time ! DC braking is not possible when using a synchronous motor (i.e. P0300 = 2).</p>		
Notice:	<p>The DC braking function causes the motor to stop rapidly by applying a DC braking current. When the DC braking signal is applied, the inverter output pulses are blocked and the DC current not applied until the motor has been sufficiently demagnetized (demagnetization time is calculated automatically from motor data).</p>		
Note:	<p>P1233 = 0 means that DC braking is not activated.</p>		



p1234[0...2]	DC braking start frequency / DC brk. start freq		
	Access level: 2	Calculated: -	Data type: FloatingPoint32
	Can be changed: C, U, T	Scaling: -	Data set: DDS
	Min 0.00 [Hz]	Max 650.00 [Hz]	Factory setting 650.00 [Hz]
Description:	Sets start frequency for DC braking. When an OFF1 or OFF3 command is received by the drive, the output frequency starts to ramp to 0 Hz. When the output frequency reaches the value set in start frequency of DC braking P1234, the drive injects a DC braking current P1232 for the time duration set in P1233.		

p1237	Dynamic braking / Dynamic braking		
	Access level: 2	Calculated: -	Data type: Unsigned16
	Can be changed: C, U, T	Scaling: -	Data set: -
	Min 0	Max 5	Factory setting 0
Description:	Dynamic braking absorbs the braking energy in a chopper resistor. This parameter defines the rated duty cycle of the braking resistor (chopper resistor). Dynamic braking is active when the function is enabled and DC-link voltage exceeds the dynamic braking switch-on level. Dynamic braking switch-on level (V_DC,Chopper) : If p1254 = 0 --> $V_{DC,Chopper} = 1.13 * \sqrt{2} * V_{mains} = 1.13 * \sqrt{2} * p0210$ otherwise $V_{DC,Chopper} = 0.98 * r1242$		
Value:	0: Disabled 1: 5 % duty cycle 2: 10 % duty cycle 3: 20 % duty cycle 4: 50 % duty cycle 5: 100 % duty cycle		
Dependency:	If dynamic braking is used with DC braking enabled, DC braking will take priority.		

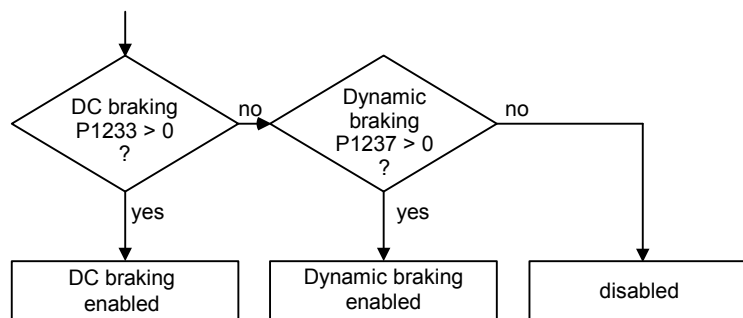

Notice:	Initially the brake will operate at a high duty cycle dependant on the DC link level until the thermal limit is approached. The duty cycle specified by this parameter will then be imposed. The resistor should be able to operate at this level indefinitely without overheating.
----------------	-------------------------------------------------------------------------------------------------------------------------------------------------------------------------------------------------------------------------------------------------------------------------------------------

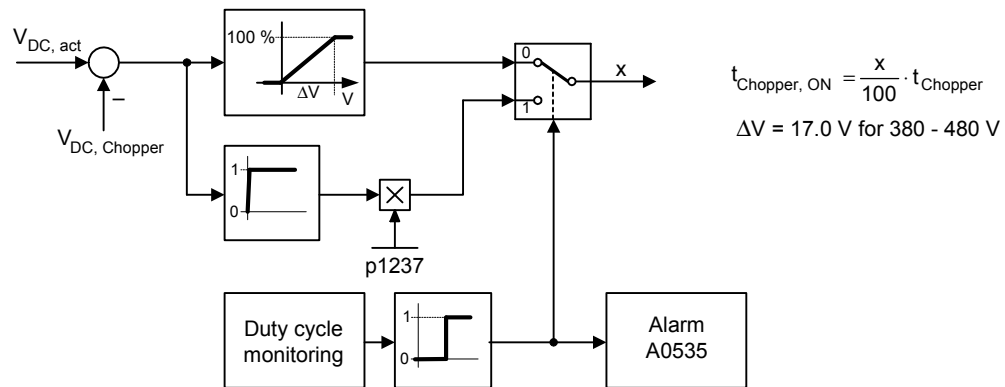

The threshold for the warning A0535 is equivalent to 10 seconds running at 95 % duty cycle.
The duty cycle will be limited when it was running 12 seconds at 95 % duty cycle.

p1240[0...2] Configuration of Vdc controller / Vdc controller

Access level: 3	Calculated: -	Data type: Unsigned16
Can be changed: C, T	Scaling: -	Data set: DDS
Min 0	Max 1	Factory setting 0

Description: Enables / disables Vdc controller.
The Vdc controller dynamically controls the DC link voltage to prevent overvoltage trips on high inertia systems.

Value:
0: Vdc controller disabled
1: Vdc-max controller enabled

Note:

- Vdc-max controller:
Vdc-max controller automatically increases ramp-down times to keep the DC-link voltage (r0026) within limits (r1242).

r1242 CO: Switch-on level of Vdc-max / Vdc-max ON lev

Access level: 3	Calculated: -	Data type: FloatingPoint32
Unit: [V]	Scaling: -	Data set: -

Description: Displays switch-on level of Vdc max controller.
Following equation is only valid, if p1254 = 0 :
 $r1242 = 1.15 * \sqrt{2} * V_{\text{mains}} = 1.15 * \sqrt{2} * p0210$
otherwise r1242 is internally calculated.

p1243[0...2] Dynamic factor of Vdc-max / Vdc-max dyn. fact.

Access level: 3	Calculated: -	Data type: Unsigned16
Can be changed: C, U, T	Scaling: -	Data set: DDS
Min 10 [%]	Max 200 [%]	Factory setting 100 [%]

Description: Defines dynamic factor for DC link controller in [%].

Dependency: P1243 = 100 % means parameters P1250, P1251 and P1252 (gain, integration time and differential time) are used as set. Otherwise, these are multiplied by P1243 (dynamic factor of Vdc-max).

Note: Vdc controller adjustment is calculated automatically from motor and inverter data.

p1250[0...2]	Gain of Vdc-controller / Gain of Vdc ctrl.		
	Access level: 3	Calculated: -	Data type: FloatingPoint32
	Can be changed: C, U, T	Scaling: -	Data set: DDS
	Min 0.00	Max 10.00	Factory setting 1.00
Description:	Enters gain for Vdc controller.		
p1251[0...2]	Integration time Vdc-controller / Int. time Vdc ctrl		
	Access level: 3	Calculated: -	Data type: FloatingPoint32
	Can be changed: C, U, T	Scaling: -	Data set: DDS
	Min 0.1 [ms]	Max 1000.0 [ms]	Factory setting 40.0 [ms]
Description:	Enters integral time constant for Vdc controller.		
p1252[0...2]	Differential time Vdc-controller / Diff.time Vdc ctrl		
	Access level: 3	Calculated: -	Data type: FloatingPoint32
	Can be changed: C, U, T	Scaling: -	Data set: DDS
	Min 0.0 [ms]	Max 1000.0 [ms]	Factory setting 1.0 [ms]
Description:	Enters differential time constant for Vdc controller.		
p1253[0...2]	Vdc-controller output limitation / Vdc ctrl outp. lim		
	Access level: 3	Calculated: p0340 = 1,3	Data type: FloatingPoint32
	Can be changed: C, U, T	Scaling: -	Data set: DDS
	Min 0.00 [Hz]	Max 600.00 [Hz]	Factory setting 10.00 [Hz]
Description:	Limits maximum effect of Vdc max controller.		
Note:	The Factory setting depends on inverter power.		
p1254	Auto detect Vdc switch-on levels / Autodet Vdc ON lev		
	Access level: 3	Calculated: -	Data type: Unsigned16
	Can be changed: C, T	Scaling: -	Data set: -
	Min 0	Max 1	Factory setting 1
Description:	Enables/disables auto-detection of switch-on levels for Vdc max controller.		
Value:	0: Disabled 1: Enabled		
p1300[0...2]	Control mode / Control mode		
	Access level: 2	Calculated: -	Data type: Unsigned16
	Can be changed: C(1), T	Scaling: -	Data set: DDS
	Min 0	Max 19	Factory setting 0
Description:	Parameter to select the control method. Controls relationship between speed of motor and voltage supplied by inverter.		
Value:	0: V/f with linear characteristic 1: V/f with FCC 2: V/f with quadratic characteristic 3: V/f with programmable characteristic 4: reserved 5: V/f for textile applications		

6: V/f with FCC for textile applications
 19: V/f control with independent voltage setpoint

Dependency:

See parameter P0205, P0500

Note:

P1300 = 1 : V/f with FCC (flux current control)

- Maintains motor flux current for improved efficiency.
- If FCC is chosen, linear V/f is active at low frequencies.

P1300 = 2 : V/f with a quadratic characteristic

- Suitable for centrifugal fans / pumps

P1300 = 3 : V/f with a programmable characteristic

- User defined characteristic (see P1320)
- For synchronous motors (e.g. SIEMOSYN motors)

P1300 = 5,6 : V/f for textile applications

- Slip compensation disabled.
- I_{max} controller modifies the output voltage only.
- I_{max} controller does not influence the output frequency.

P1300 = 19 : V/f control with independent voltage setpoint

The following table presents an overview of control parameters (V/f) that can be modified in relationship to P1300 dependencies:

ParNo.	Parameter name	Level	V/f							
			p1300 =							
			0	1	2	3	5	6	19	
p1300[3]	Control mode	2	x	x	x	x	x	x	x	
p1310[3]	Continuous boost	2	x	x	x	x	x	x	x	
p1311[3]	Acceleration boost	2	x	x	x	x	x	x	x	
p1312[3]	Starting boost	2	x	x	x	x	x	x	x	
p1316[3]	Boost end frequency	3	x	x	x	x	x	x	x	
p1320[3]	Programmable V/f freq. coord. 1	3	-	-	-	x	-	-	-	
p1321[3]	Programmable V/f volt. coord. 1	3	-	-	-	x	-	-	-	
p1322[3]	Programmable V/f freq. coord. 2	3	-	-	-	x	-	-	-	
p1323[3]	Programmable V/f volt. coord. 2	3	-	-	-	x	-	-	-	
p1324[3]	Programmable V/f freq. coord. 3	3	-	-	-	x	-	-	-	
p1325[3]	Programmable V/f volt. coord. 3	3	-	-	-	x	-	-	-	
p1330[3]	Cl: Voltage setpoint	3	-	-	-	-	-	-	x	
p1333[3]	Start frequency for FCC	3	-	x	-	-	-	x	-	
p1335[3]	Slip compensation	2	x	x	x	x	-	-	-	
p1336[3]	CO: U/f Slip limit	2	x	x	x	x	-	-	-	
p1338[3]	Resonance damping gain V/f	3	x	x	x	x	-	-	-	
p1340[3]	I _{max} freq. controller prop. gain	3	x	x	x	x	x	x	x	
p1341[3]	I _{max} controller integral time	3	x	x	x	x	x	x	x	
p1345[3]	I _{max} controller prop. gain	3	x	x	x	x	x	x	x	
p1346[3]	I _{max} voltage ctrl. integral time	3	x	x	x	x	x	x	x	
p1350[3]	Voltage soft start	3	x	x	x	x	x	x	x	

p1310[0...2]	Continuous boost / Continuous boost		
	Access level: 2	Calculated: -	Data type: FloatingPoint32
	Can be changed: U, T	Scaling: PERCENT	Data set: DDS
	Min 0.0 [%]	Max 250.0 [%]	Factory setting 50.0 [%]
Description:	<p>Defines boost level in [%] relative to P0305 (rated motor current) applicable to both linear and quadratic V/f curves. At low output frequencies the output voltage is low to keep the flux level constant. However, the output voltage may be too low for the following:</p> <ul style="list-style-type: none"> • magnetisation the asynchronous motor • hold the load • overcome losses in the system. <p>The inverter output voltage can be increased via P1310 for the compensation of losses, hold loads at 0 Hz or maintain the magnetization.</p> <p>The magnitude of the boost in Volt at a frequency of zero is defined as follows: $V_ConBoost,100 = p0305 * p0350 * (p1310 / 100)$</p>		
Note:	<p>Increasing the boost levels increases motor heating (especially at standstill). Setting in P0640 (motor overload factor [%]) limits the boost: $sum(V_Boost) / (p0305 * p0350) \leq p1310 / 100$</p> <p>The boost values are combined when continuous boost (P1310) used in conjunction with other boost parameters (acceleration boost P1311 and starting boost P1312). However priorities are allocated to these parameters as follows: $P1310 > P1311 > P1312$</p> <p>The total boost is limited by following equation: $sum(V_Boost) \leq 3 * R_S * I_Mot = 3 * p0305 * p0350$</p>		
p1311[0...2]	Acceleration boost / Acceleration boost		
	Access level: 2	Calculated: -	Data type: FloatingPoint32
	Can be changed: U, T	Scaling: PERCENT	Data set: DDS
	Min 0.0 [%]	Max 250.0 [%]	Factory setting 0.0 [%]
Description:	<p>Applies boost in [%] relative to P0305 (rated motor current) following a positive setpoint change and drops back out once the setpoint is reached.</p> <p>P1311 will only produce boost during ramping, and is therefore useful for additional torque during acceleration and deceleration.</p> <p>As opposed to parameter P1312, which is only active on the first acceleration issued after the ON command, parameter P1311 is always effect during an acceleration and deceleration when issued.</p> <p>The magnitude of the boost in Volt at a frequency of zero is defined as follows: $V_AccBoost,100 = p0305 * p0350 * (p1311 / 100)$</p>		
Note:	See parameter P1310.		
p1312[0...2]	Starting boost / Starting boost		
	Access level: 2	Calculated: -	Data type: FloatingPoint32
	Can be changed: U, T	Scaling: PERCENT	Data set: DDS
	Min 0.0 [%]	Max 250.0 [%]	Factory setting 0.0 [%]
Description:	<p>Applies a constant linear offset (in [%] relative to P0305 (rated motor current)) to active V/f curve (either linear or quadratic) after an ON command and is active until:</p> <ol style="list-style-type: none"> 1. ramp output reaches setpoint for the first time respectively 2. setpoint is reduced to less than present ramp output <p>This is useful for starting loads with high inertia. Setting the starting boost (P1312) too high will cause the inverter to limit the current, which will in turn restrict the output frequency to below the setpoint frequency.</p> <p>The magnitude of the boost in Volt at a frequency of zero is defined as follows: $V_StartBoost,100 = p0305 * p0350 * (p1312 / 100)$</p>		

Note: See parameter P1310.

r1315	CO: Total boost voltage / Total boost V		
	Access level: 4	Calculated: -	Data type: FloatingPoint32
	Unit: [V]	Scaling: -	Data set: -
Description:	Displays total value of voltage boost (in volts).		
p1316[0...2]	Boost end frequency / Boost end freq.		
	Access level: 3	Calculated: p0340 = 1,3	Data type: FloatingPoint32
	Can be changed: U, T	Scaling: PERCENT	Data set: DDS
	Min 0.0 [%]	Max 100.0 [%]	Factory setting 20.0 [%]
Description:	Defines point at which programmed boost reaches 50 % of its value. This value is expressed in [%] relative to P0310 (rated motor frequency). The default frequency is defined as follows: $V_Boost,min = 2 * (3 + (153 / \sqrt{P_Motor}))$		
Note:	The expert user may change this value to alter the shape of the curve, e.g. to increase torque at a particular frequency. Default value is depending on inverter type and its rating data.		
p1320[0...2]	Programmable V/f freq. coord. 1 / V/f freq. coord. 1		
	Access level: 3	Calculated: -	Data type: FloatingPoint32
	Can be changed: T	Scaling: -	Data set: DDS
	Min 0.00 [Hz]	Max 650.00 [Hz]	Factory setting 0.00 [Hz]
Description:	Sets the frequency of the first point of V/f coordinates (P1320/1321 to P1324/1325) to define V/f characteristic. These parameter pairs can be used to provide correct torque at correct frequency and is useful when used with synchronous motors.		
Dependency:	To set parameter, select P1300 = 3 (V/f with programmable characteristic). The acceleration boost and starting boost defined in P1311 and P1312 are applied to V/f with programmable characteristic.		
Note:	Linear interpolation will be applied between the individual data points. V/f with programmable characteristic (P1300 = 3) has 3 programmable points and 2 non-programmable points. The 2 non-programmable points are: <ul style="list-style-type: none"> • Continuous boost P1310 at 0 Hz • Rated motor voltage P0304 at rated motor frequency P0310 		
p1321[0...2]	Programmable V/f volt. coord. 1 / V/f volt. coord. 1		
	Access level: 3	Calculated: -	Data type: FloatingPoint32
	Can be changed: U, T	Scaling: -	Data set: DDS
	Min 0.0 [V]	Max 3000.0 [V]	Factory setting 0.0 [V]
Description:	See P1320 (programmable V/f freq. coord. 1).		
p1322[0...2]	Programmable V/f freq. coord. 2 / V/f freq. coord. 2		
	Access level: 3	Calculated: -	Data type: FloatingPoint32
	Can be changed: T	Scaling: -	Data set: DDS
	Min 0.00 [Hz]	Max 650.00 [Hz]	Factory setting 0.00 [Hz]
Description:	See P1320 (programmable V/f freq. coord. 1).		

p1323[0...2]	Programmable V/f volt. coord. 2 / V/f volt. coord. 2		
	Access level: 3	Calculated: -	Data type: FloatingPoint32
	Can be changed: U, T	Scaling: -	Data set: DDS
	Min 0.0 [V]	Max 3000.0 [V]	Factory setting 0.0 [V]
Description:	See P1320 (programmable V/f freq. coord. 1).		
p1324[0...2]	Programmable V/f freq. coord. 3 / V/f freq. coord. 3		
	Access level: 3	Calculated: -	Data type: FloatingPoint32
	Can be changed: T	Scaling: -	Data set: DDS
	Min 0.00 [Hz]	Max 650.00 [Hz]	Factory setting 0.00 [Hz]
Description:	See P1320 (programmable V/f freq. coord. 1).		
p1325[0...2]	Programmable V/f volt. coord. 3 / V/f volt. coord. 3		
	Access level: 3	Calculated: -	Data type: FloatingPoint32
	Can be changed: U, T	Scaling: -	Data set: DDS
	Min 0.0 [V]	Max 3000.0 [V]	Factory setting 0.0 [V]
Description:	See P1320 (programmable V/f freq. coord. 1).		
p1330[0...2]	CI: Voltage setpoint / Voltage setp.		
	Access level: 3	Calculated: -	Data type: U32 / FloatingPoint32
	Can be changed: T	Scaling: -	Data set: CDS
	Min -	Max -	Factory setting 0
Description:	BICO parameter for selecting source of voltage setpoint for independent V/f control (P1300 = 19).		
p1333[0...2]	Start frequency for FCC / Start freq for FCC		
	Access level: 3	Calculated: -	Data type: FloatingPoint32
	Can be changed: U, T	Scaling: PERCENT	Data set: DDS
	Min 0.0 [%]	Max 100.0 [%]	Factory setting 10.0 [%]
Description:	Defines start frequency at which FCC (flux current control) is enabled as [%] of rated motor frequency (P0310).		
Notice:	If this value is too low, the system may become unstable.		

p1334[0...2] Slip compensation activation range / Slip c. act. range

Access level: 3	Calculated: -	Data type: FloatingPoint32
Can be changed: U, T	Scaling: PERCENT	Data set: DDS
Min 1.0 [%]	Max 20.0 [%]	Factory setting 6.0 [%]

Description: To set the frequency activation range for slip compensation. The percentage value of P1334 refers to the motor rated frequency P0310. The upper threshold will always stay 4 % above P1334.

Range of slip compensation :

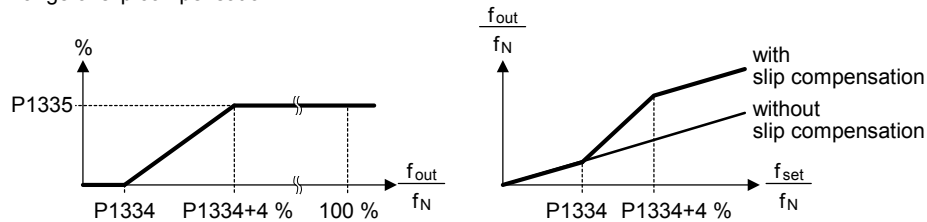

Dependency: Slip compensation (P1335) active.

Note: See parameter P1335.
The starting frequency of the slip compensation is P1334 * P0310.

p1335[0...2] Slip compensation / Slip compensation

Access level: 2	Calculated: -	Data type: FloatingPoint32
Can be changed: U, T	Scaling: PERCENT	Data set: DDS
Min 0.0 [%]	Max 600.0 [%]	Factory setting 0.0 [%]

Description: Parameter dynamically adjusts inverter output frequency so that motor speed is kept constant independent of motor load.

In the V/f-control, the motor frequency will always be less than the inverter output frequency due to the slip frequency. For a given output frequency, the motor frequency will drop as load is increased. This behavior, typical for induction motors, can be compensated using slip compensation. P1335 can be used to enable and fine-tune the slip compensation.

Dependency: P1335 > 0, P1336 > 0, P1337 = 0 if P1300 = 5, 6.

Notice: The applied value of the slip compensation (scaled by P1335) is limited by following equation:

$$f_{\text{Slip_comp,max}} = r0330 * (P1336 / 100)$$

Note: P1335 = 0 % :

Slip compensation disabled.

P1335 = 50 % - 70 % :

Full slip compensation at cold motor (partial load).

P1335 = 100 % (standard setting for warm stator) :

Full slip compensation at warm motor (full load).

p1336[0...2] Slip limit / Slip limit

Access level: 2	Calculated: -	Data type: Unsigned16
Can be changed: U, T	Scaling: -	Data set: DDS
Min 0 [%]	Max 600 [%]	Factory setting 250 [%]

Description: Compensation slip limit in [%] relative to r0330 (rated motor slip), which is added to frequency setpoint.

Dependency: Slip compensation (P1335) active.

r1337	CO: V/f slip frequency / V/f slip freq.		
	Access level: 3	Calculated: -	Data type: FloatingPoint32
	Unit: [%]	Scaling: PERCENT	Data set: -
Description:	Displays actual compensated motor slip as [%]. $f_{\text{slip}} [\text{Hz}] = r1337 [\%] * P0310 / 100$		
Dependency:	Slip compensation (P1335) active.		
p1338[0...2]	Resonance damping gain V/f / Res.damp. gain V/f		
	Access level: 3	Calculated: p0340 = 1,3,4	Data type: FloatingPoint32
	Can be changed: U, T	Scaling: -	Data set: DDS
	Min 0.00	Max 10.00	Factory setting 0.00
Description:	Defines resonance damping gain for V/f. The di/dt of the active current will be scaled by P1338. If di/dt increases the resonance damping circuit decreases the inverter output frequency.		
Note:	The resonance circuit damps oscillations of the active current which frequently occur during no-load operation. In V/f modes (see P1300), the resonance damping circuit is active in a range from approx. 6 % to 80 % of rated motor frequency (P0310). If the value of P1338 is too high, this will cause instability (forward control effect).		
p1340[0...2]	I_{max} controller prop. gain / I_{max} ctrl prp gain		
	Access level: 3	Calculated: -	Data type: FloatingPoint32
	Can be changed: U, T	Scaling: -	Data set: DDS
	Min 0.000	Max 0.499	Factory setting 0.000
Description:	Proportional gain of the I _{max} controller. The I _{max} controller reduces inverter current if the output current exceeds the maximum motor current (r0067). In linear V/f, parabolic V/f, FCC, and programmable V/f modes the I _{max} controller uses both a frequency controller (see parameters P1340 and P1341) and a voltage controller (see parameters P1345 and P1346). The frequency controller seeks to reduce current by limiting the inverter output frequency (to a minimum of the two times nominal slip frequency). If this action does not successfully remove the overcurrent condition, the inverter output voltage is reduced using the I _{max} voltage controller. When the overcurrent condition has been removed successfully, frequency limiting is removed using the ramp-up time set in P1120. In linear V/f for textiles, FCC for textiles, or external V/f modes only the I _{max} voltage controller is used to reduce current (see parameters P1345 and P1346).		
Note:	The I _{max} controller can be disabled by setting the frequency controller integral time P1341 to zero. This disables both the frequency and voltage controllers. Note that when disabled, the I _{max} controller will take no action to reduce current but overcurrent warnings will still be generated, and the drive will trip in excessive overcurrent or overload conditions.		
p1341[0...2]	I_{max} controller integral time / I_{max} ctrl int time		
	Access level: 3	Calculated: p0340 = 1,3,4	Data type: FloatingPoint32
	Can be changed: U, T	Scaling: -	Data set: DDS
	Min 0.000 [s]	Max 50.000 [s]	Factory setting 0.300 [s]
Description:	Integral time constant of the I _{max} controller. <ul style="list-style-type: none"> • P1341 = 0 : I_{max} controller disabled • P1340 = 0 and P1341 > 0 : frequency controller enhanced integral • P1340 > 0 and P1341 > 0 : frequency controller normal PI control 		
Note:	See parameter P1340 for further information. The Factory setting depends on inverter power.		

r1343	CO: I_{max} controller freq. output / I_{max} ctrl Foutp		
	Access level: 3	Calculated: -	Data type: FloatingPoint32
	Unit: [Hz]	Scaling: -	Data set: -
Description:	Displays effective frequency limitation.		
Dependency:	If I _{max} controller not in operation, parameter normally shows max. frequency P1082.		
r1344	CO: I_{max} controller volt. output / I_{max} ctrl Voutp		
	Access level: 3	Calculated: -	Data type: FloatingPoint32
	Unit: [V]	Scaling: -	Data set: -
Description:	Displays amount by which the I _{max} controller is reducing the inverter output voltage.		
p1345[0...2]	I_{max} voltage ctrl. prop. gain / I_{max} volt prp gain		
	Access level: 3	Calculated: p0340 = 1,3,4	Data type: FloatingPoint32
	Can be changed: U, T	Scaling: -	Data set: DDS
	Min 0.000	Max 5.499	Factory setting 0.250
Description:	If the output current (r0068) exceeds the maximum current (r0067), the frequency inverter is dynamically controlled by reducing the output voltage. This parameter sets the proportional gain of this controller.		
Note:	See parameter P1340 for further information. The Factory setting depends on inverter power.		
p1346[0...2]	I_{max} voltage ctrl. integral time / I_{max} volt int time		
	Access level: 3	Calculated: p0340 = 1,3,4	Data type: FloatingPoint32
	Can be changed: U, T	Scaling: -	Data set: DDS
	Min 0.000 [s]	Max 50.000 [s]	Factory setting 0.300 [s]
Description:	Integral time constant of the I _{max} voltage controller. <ul style="list-style-type: none"> • P1341 = 0 : I_{max} controller disabled • P1345 = 0 and P1346 > 0 : I_{max} voltage controller enhanced integral • P1345 > 0 and P1346 > 0 : I_{max} voltage controller normal PI control 		
Note:	See parameter P1340 for further information. The Factory setting depends on inverter power.		
p1350[0...2]	Voltage soft start / Voltage soft start		
	Access level: 3	Calculated: -	Data type: Unsigned16
	Can be changed: U, T	Scaling: -	Data set: DDS
	Min 0	Max 1	Factory setting 0
Description:	Sets whether voltage is built up smoothly during magnetization time (ON) or whether it simply jumps to boost voltage (OFF).		
Value:	0: OFF 1: ON		
Note:	The settings for this parameter bring benefits and drawbacks: <ul style="list-style-type: none"> • P1350 = 0: OFF (jump to boost voltage) Benefit: flux is built up quickly Drawback: motor may move • P1350 = 1: ON (smooth voltage build-up) Benefit: motor less likely to move Drawback: flux build-up takes longer 		

p1800[0...2]	Pulse frequency / Pulse frequency		
	Access level: 2	Calculated: -	Data type: Unsigned16
	Can be changed: U, T	Scaling: -	Data set: DDS
	Min 2 [kHz]	Max 16 [kHz]	Factory setting 4 [kHz]
Description:	Sets pulse frequency of power switches in inverter. The frequency can be changed in steps of 2 kHz.		
Dependency:	The minimum/maximum/default values of the pulse frequency are determined by the used power module. Furthermore the minimum pulse frequency depends on the parametrization of P1082 (maximum frequency) and P0310 (rated motor frequency).		
Note:	If the pulse frequency is increased, max. inverter current r0209 can be reduced (derating). The derating characteristic depends on the type and power of the inverter. If silent operation is not absolutely necessary, lower pulse frequencies may be selected to reduce inverter losses and radio-frequency emissions. Under certain circumstances, the inverter may reduce the pulse frequency to provide protection against overtemperature (see P0290 and P0291 Bit00).		
r1801[0...1]	CO: Pulse frequency / Pulse frequency		
	Access level: 3	Calculated: -	Data type: Unsigned16
	Unit: [kHz]	Scaling: -	Data set: -
Description:	Displays informations about pulse frequency of power switches in inverter. r1801[0] Displays the actual inverter pulse frequency. r1801[1] Displays the minimum inverter pulse frequency which can be reached when the functions "motor identification" or "inverter overload reaction" are active. If no PM is plugged this parameter is set to 0 kHz.		
Index:	[0] = Actual pulse frequency [1] = Minimum pulse frequency		
Notice:	Under certain conditions (inverter overtemperature, see P0290), this can differ from the values selected in P1800 (pulse frequency).		
p1802	Modulator mode / Modulator mode		
	Access level: 3	Calculated: -	Data type: Unsigned16
	Can be changed: U, T	Scaling: -	Data set: -
	Min 1	Max 3	Factory setting 3
Description:	Selects inverter modulator mode.		
Value:	1: Asymmetric SVM 2: Space vector modulation 3: SVM/ASVM controlled mode		
Notice:	<ul style="list-style-type: none"> Asymmetric space vector modulation (ASVM) produces lower switching losses than space vector modulation (SVM), but may cause irregular rotation at very low speeds. Space vector modulation (SVM) with over-modulation may produce current waveform distortion at high output voltages. Space vector modulation (SVM) without over-modulation will reduce maximum output voltage available to motor. 		
p1803[0...2]	Max. modulation / Max. modulation		
	Access level: 3	Calculated: -	Data type: FloatingPoint32
	Can be changed: U, T	Scaling: -	Data set: DDS
	Min 20.0 [%]	Max 150.0 [%]	Factory setting 100.0 [%]
Description:	Sets maximum modulation index.		
Note:	P1803 = 100 % : Limit for over-control (for ideal inverter without switching delay).		

p1810	Control word Vdc control / Control word vdc c			
	Access level: 3	Calculated: -	Data type: Unsigned16	
	Can be changed: U, T	Scaling: -	Data set: -	
	Min -	Max -	Factory setting 0010 bin	
Description:	Configures Vdc filtering and compensation.			
Bit field:	Bit	Signal name	1 signal	0 signal
	00	enable Vdc average filter	Yes	No
	01	enable Vdc compensation	Yes	No
				FP -
				-
p1820[0...2]	Reverse output phase sequence / Rev.outp.phase seq			
	Access level: 2	Calculated: -	Data type: Unsigned16	
	Can be changed: T	Scaling: -	Data set: DDS	
	Min 0	Max 1	Factory setting 0	
Description:	Changes sequence of phases without changing setpoint polarity.			
Value:	0: Forward 1: Reverse the Motor			
Note:	See P1000 (select frequency setpoint)			
p1825	On-state voltage of IGBT / On-state voltage			
	Access level: 4	Calculated: -	Data type: FloatingPoint32	
	Can be changed: U, T	Scaling: -	Data set: -	
	Min 0.0 [V]	Max 20.0 [V]	Factory setting 0.9 [V]	
Description:	Corrects on-state voltage of the IGBTs.			
p1828	Gating unit dead time / Gating dead time			
	Access level: 4	Calculated: -	Data type: FloatingPoint32	
	Can be changed: U, T	Scaling: -	Data set: -	
	Min 0.00 [µs]	Max 3.98 [µs]	Factory setting 0.01 [µs]	
Description:	Sets compensation time of gating unit interlock.			
p1900	Select motor data identification / Sel.mot.data ident			
	Access level: 2	Calculated: -	Data type: Unsigned16	
	Can be changed: C(1), T	Scaling: -	Data set: -	
	Min 0	Max 3	Factory setting 0	
Description:	Performs a motor data identification.			
Value:	0: Disabled 2: Identification of all parameters in standstill 3: Ident. of all param. in standstill incl. the saturation curve			
Dependency:	No measurement if motor data incorrect.			
Notice:	P1900 = 2 or 3 : Calculated value for stator resistance (see P0350) is overwritten. P1910 can't be changed while the motoridentification is active (P1900 = 2 or 3). When the identification is finished P1900 and P1910 are set to 0. When choosing the setting for measurement, observe the following: The value is actually adopted as P0350 parameter setting and applied to the control as well as being shown in the read-only parameters below. Ensure that the motor holding brake is not active when performing the motor identification.			

- Note:** Before selecting motor data identification, "Quick commissioning" has to be performed in advance.
- Since the cable length of the applications differ in a wide range the preset resistor P0352 is only a rough estimation. Better results of the motor identification can be achieved by specifying the cable resistor before the start of the motor identification by measuring/calculating.
- Once enabled (P1900 > 0), A0541 generates a warning that the next ON command will initiate measurement of motor parameters.
- Communications - both via USS as well as via the Fieldbus - are interrupted for the time that it takes to make internal calculations.
- This can result in the following error messages at the connected SIMATIC S7 control (communications via fieldbus):
- Parameter fault 30
 - Drive fault 70
 - Drive fault 75
- When using STARTER (USS) to commission the drive system, data cannot be entered while these calculations are being made.
- The faults can be acknowledged as soon as the calculations have been completed in the frequency inverter. These calculations can take up to one minute to complete.

p1909[0...2]		Ctrl. word of motor data ident. / Ctrl.mot.data id.			
Access level: 4		Calculated: -	Data type: Unsigned16		
Can be changed: U, T		Scaling: -	Data set: DDS		
Min		Max	Factory setting		
-		-	0101 1100 0000 0000 bin		
Description:	Control word of motor data identification.				
Bit field:	Bit	Signal name	1 signal	0 signal	FP
	00	Estimation of Xs	Yes	No	-
	01	Motor ID at 2KHz	Yes	No	-
	02	Estimation of Tr	Yes	No	-
	03	Estimation of Lsigma	Yes	No	-
	05	Det. Tr meas. with 2 freq.	Yes	No	-
	06	Measurement of on voltage	Yes	No	-
	07	Deadtime detection from Rs measurement	Yes	No	-
	08	MotID with hw deadtime comp activ	Yes	No	-
	09	No deadtime detection with 2 freq	Yes	No	-
	10	Detect Ls with LsBlock method	Yes	No	-
	11	MotID adaption of magnetizing current	Yes	No	-
	12	MotID adaption of main reactance	Yes	No	-
	13	MotID switch off saturation curve optim.	Yes	No	-
	14	MotID saturation curve optim. all framesizes	Yes	No	-
	15	MotID saturation curve optim. big framesizes	Yes	No	-

p1910		Select motor data identification extended / Sel.mot.data ident		
Access level: 2		Calculated: -	Data type: Unsigned16	
Can be changed: T		Scaling: -	Data set: -	
Min		Max	Factory setting	
0		23	0	
Description:	Performs a motor data identification with extended figures.			
Value:	0:	Disabled		
	1:	Identification of all parameters with parameter change		
	2:	Identification of all parameters without parameter change		
	3:	Identification of saturation curve with parameter change		
	4:	Identification of saturation curve without parameter change		
	5:	Identification of XsigDyn (r1920) without parameter change		
	6:	Identification of Tdead (r1926) without parameter change		
	7:	Identification of Rs (r1912) without parameter change		
	8:	Identification of Xs (r1915) without parameter change		
	9:	Identification of Tr (r1913) without parameter change		
	10:	Identification of Xsigma (r1914) without parameter change		

- 20: Set voltage vector
 21: Set voltage vector without filtering in P0069
 22: Set voltage vector rectangle signal
 23: Set voltage vector triangle signal

Dependency:

No measurement if motor data incorrect.

P1910 = 1 : Calculated value for stator resistance (see P0350) is overwritten.

Notice:

Ensure that the motor holding brake is not active when performing the motor identification.

P1910 can't be changed while the motor identification with P1900 is active (P1900 = 2 or 3).

When the identification is finished P1910 is set to 0.

When choosing the setting for measurement, observe the following:

1. "with parameter change"
means that the value is actually adopted as P0350 parameter setting and applied to the control as well as being shown in the read-only parameters below.
2. "without parameter change"
means that the value is only displayed, i.e. shown for checking purposes in the read-only parameter r1912 (identified stator resistance).

The value is not applied to the control.

Note:

Before selecting motor data identification, "Quick commissioning" has to be performed in advance.

Since the cable length of the applications differ in a wide range the preset resistor P0352 is only a rough estimation. Better results of the motor identification can be achieved by specifying the cable resistor before the start of the motor identification by measuring/calculating.

Once enabled (P1910 > 0), A0541 generates a warning that the next ON command will initiate measurement of motor parameters.

Communications - both via USS as well as via the Fieldbus - are interrupted for the time that it takes to make internal calculations.

This can result in the following error messages at the connected SIMATIC S7 control (communications via fieldbus):

- Parameter fault 30
- Drive fault 70
- Drive fault 75

When using STARTER (USS) to commission the drive system, data cannot be entered while these calculations are being made.

The faults can be acknowledged as soon as the calculations have been completed in the frequency inverter. These calculations can take up to one minute to complete.

p1911**No. of phase to be identified / No.of phase for id**

Access level: 2	Calculated: -	Data type: Unsigned16
Can be changed: T	Scaling: -	Data set: -
Min	Max	Factory setting
1	3	1

Description:

Selects maximum number of motor phases to be identified.

Note:

Because of averaging (measurement inprecisseness and variations in the phase) a measurement with 3 phases delivers better results than a one phase measurement, but needs significant longer measurement time.

r1912[0...2]**Identified stator resistance / Identif. stat. res**

Access level: 2	Calculated: -	Data type: FloatingPoint32
Unit: [Ohm]	Scaling: -	Data set: -

Description:

Displays measured stator resistance value (line-to-line) in [Ohms]. This value also includes the cable resistances.

Index:

[0] = U_phase
 [1] = V_phase
 [2] = W_phase

Notice:

If the value identified (R_s = stator resistance) does not lie within the range $0.1\% < R_s [p. u.] < 100\%$ fault message 41 (motor data identification failure) is issued.

P0949 provides further information (fault value = 2 in this case).

Note:

This value is measured using P1900 = 2 or 3 (P1910 = 1 or 2) , i.e., identification of all parameters with/without change.

r1913[0...2]	Identified rotor time constant / Identif.rot.Tconst		
	Access level: 2	Calculated: -	Data type: FloatingPoint32
	Unit: [ms]	Scaling: -	Data set: -
Description:	Displays identified rotor time constant. [msec]		
Index:	[0] = U_phase [1] = V_phase [2] = W_phase		
Notice:	If the value identified (T_r = rotor time constant) does not lie within the range $10\text{ms} < T_r < 5\text{s}$ fault message 41 (motor data identification failure) is issued. P0949 provides further information (fault value = 6 in this case).		
r1914[0...2]	Ident. total leakage inductance / Tot.leak.induct.		
	Access level: 2	Calculated: -	Data type: FloatingPoint32
	Unit: [mH]	Scaling: -	Data set: -
Description:	Displays identified total leakage inductance. [mH]		
Index:	[0] = U_phase [1] = V_phase [2] = W_phase		
Notice:	If the value identified (L_{σ} = leakage inductance) does not lie within the range $5\% < X_{\sigma} [\text{p. u.}] < 50\%$ fault message 41 (motor data identification failure) is issued. P0949 provides further information (fault value = 7 in this case).		
r1915[0...2]	Ident. nom. stator inductance / Nom.stat.induct.		
	Access level: 2	Calculated: -	Data type: FloatingPoint32
	Unit: [mH]	Scaling: -	Data set: -
Description:	Displays identified stator inductance. [mH]		
Index:	[0] = U_phase [1] = V_phase [2] = W_phase		
Notice:	If the value identified (L_s = stator inductance) does not lie within the range $50\% < X_s [\text{p. u.}] < 500\%$ fault message 41 (motor data identification failure) is issued. P0949 provides further information (fault value = 4 in this case).		
r1916[0...2]	Identified stator inductance 1 / Stator induct. 1		
	Access level: 2	Calculated: -	Data type: FloatingPoint32
	Unit: [mH]	Scaling: -	Data set: -
Description:	Displays identified stator inductance. [mH]		
Index:	[0] = U_phase [1] = V_phase [2] = W_phase		
Note:	See P1915 (identified nominal stator inductance).		
r1917[0...2]	Identified stator inductance 2 / Stator induct. 2		
	Access level: 2	Calculated: -	Data type: FloatingPoint32
	Unit: [mH]	Scaling: -	Data set: -
Description:	Displays identified stator inductance. [mH]		
Index:	[0] = U_phase [1] = V_phase [2] = W_phase		
Note:	See P1915 (identified nominal stator inductance)		

r1918[0...2]	Identified stator inductance 3 / Stator induct. 3		
	Access level: 2	Calculated: -	Data type: FloatingPoint32
	Unit: [mH]	Scaling: -	Data set: -
Description:	Displays identified stator inductance. [mH]		
Index:	[0] = U_phase [1] = V_phase [2] = W_phase		
Note:	See P1915 (identified nominal stator reactance)		
r1919[0...2]	Identified stator inductance 4 / Stator induct. 4		
	Access level: 2	Calculated: -	Data type: FloatingPoint32
	Unit: [mH]	Scaling: -	Data set: -
Description:	Displays identified stator inductance. [mH]		
Index:	[0] = U_phase [1] = V_phase [2] = W_phase		
Note:	See P1915 (identified nominal stator inductance)		
r1920[0...2]	Identified dyn. leak. inductance / Dyn. leak. induct.		
	Access level: 2	Calculated: -	Data type: FloatingPoint32
	Unit: -	Scaling: -	Data set: -
Description:	Displays identified total dynamic leakage inductance.		
Index:	[0] = U_phase [1] = V_phase [2] = W_phase		
r1925[0...2]	Identified on-state voltage / Id. on-state V.		
	Access level: 2	Calculated: -	Data type: FloatingPoint32
	Unit: [V]	Scaling: -	Data set: -
Description:	Displays identified on-state voltage of IGBT. [V]		
Index:	[0] = U_phase [1] = V_phase [2] = W_phase		
Notice:	If the identified on-state voltage does not lie within the range 0.0V < 10V fault message 41 (motor data identification failure) is issued. P0949 provides further information (fault value = 20 in this case).		
r1926	Ident. gating unit dead time / Id.gating deadtime		
	Access level: 2	Calculated: -	Data type: FloatingPoint32
	Unit: [µs]	Scaling: -	Data set: -
Description:	Displays identified dead time of gating unit interlock. [usec]		
p1930	Voltage setpoint for calibration / Volt setp. calibr.		
	Access level: 4	Calculated: -	Data type: FloatingPoint32
	Can be changed: U, T	Scaling: -	Data set: -
	Min 0 [V]	Max 1000 [V]	Factory setting 0 [V]
Description:	Specifies reference voltage for generation of a test voltage vector (e.g. used for shunt calibration). [V]		

p1931

Phase / Phase

Access level: 4

Calculated: -

Data type: Unsigned16

Can be changed: U, T

Scaling: -

Data set: -

Min

Max

Factory setting

1

12

1

Description:

Defines phase of voltage vector:

- 1: u-axis
- 2: v-axis
- 3: w-axis
- 4: -u-axis
- 5: -v-axis
- 6: -w-axis
- 7: uv-axis (30°)
- 8: wu-axis (150°)
- 9: vw-axis (270°)
- 10: -uv-axis (210°)
- 11: -wu-axi (330°)
- 12: -vw-axis (90°)

p2000[0...2]

Reference frequency / Reference freq.

Access level: 2

Calculated: -

Data type: FloatingPoint32

Can be changed: T

Scaling: -

Data set: DDS

Min

Max

Factory setting

1.00 [Hz]

650.00 [Hz]

50.00 [Hz]

Description:

Parameter P2000 represents the reference frequency for frequency values which are displayed/transferred as a percentage or a hexadecimal value.

Where:

- hexadecimal 4000 H ==> P2000 (e.g.: USS-PZD)
- percentage 100 % ==> P2000 (e.g.: AI)

Example:

If a BICO connection is made between two parameters or alternatively using P0719 or P1000, the 'unit' of the parameters (standardized (Hex) or physical (i.e. Hz) values) may differ. SINAMICS implicitly makes an automatic conversion to the target value.

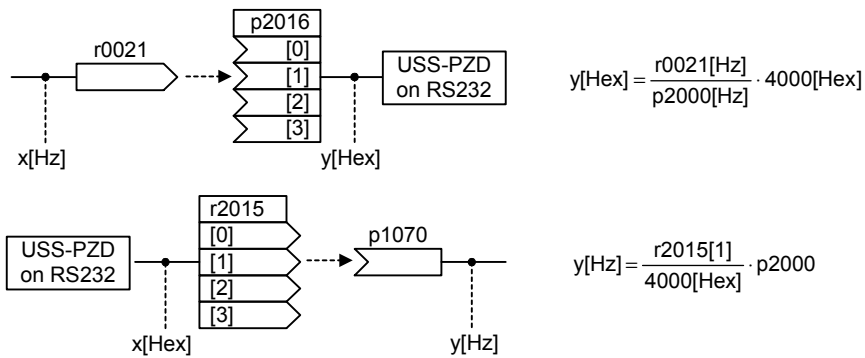

Dependency:

When Quick Commissioning is carried out P2000 is changed as follows: P2000 = P1082.

Caution:



Parameter P2000 represents the reference frequency of the above mentioned interfaces.

A maximum frequency setpoint of $2 \cdot P2000$ can be applied via the corresponding interface.

Unlike parameter P1082 (Max. Frequency) this limits the inverter frequency internally independent of the reference frequency.

By modification of P2000 it will also adapt the parameter to the new settings.

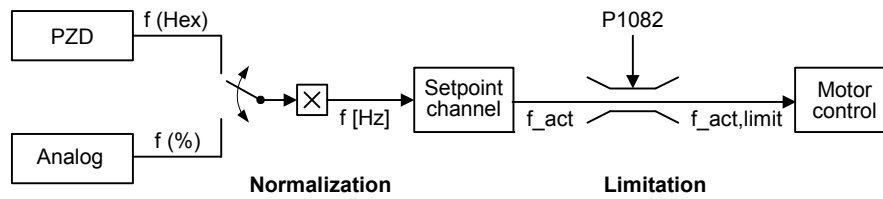

$$f[\text{Hz}] = \frac{f(\text{Hex})}{4000(\text{Hex})} \cdot p2000 = \frac{f(\%)}{100\%} \cdot P2000$$

$$f_act,limit = \min(p1082, f_act)$$

Notice: Reference parameters are intended as an aid to presenting setpoint and actual value signals in a uniform manner. This also applies to fixed settings entered as a percentage. A value of 100 % corresponds to a process data value of 4000H, or 4000 0000H in the case of double values. In this respect, the following parameters are available:

p2000	Reference frequency	Hz	
p2001	Reference voltage	V	
p2002	Reference current	A	
p2003	Reference torque	Nm	
p2004	Reference power	kW hp	f(p0100)

Note: Changes to P2000 result in a new calculation of P2004.

p2001[0...2] Reference voltage / Reference voltage

Access level: 3	Calculated: -	Data type: Unsigned16
Can be changed: T	Scaling: -	Data set: DDS
Min: 10 [V]	Max: 2000 [V]	Factory setting: 1000 [V]

Description: Full-scale output voltage (i.e. 100 %) used over serial link (corresponds to 4000H).

Example:

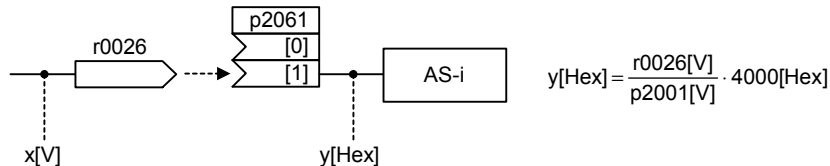

Note: Changes to P2001 result in a new calculation of P2004.

p2002[0...2] Reference current / Reference current

Access level: 3	Calculated: p0340 = 1	Data type: FloatingPoint32
Can be changed: T	Scaling: -	Data set: DDS
Min: 0.10 [A]	Max: 10000.00 [A]	Factory setting: 0.10 [A]

Description: Full-scale output current used over serial link (corresponds to 4000H).

Example: If a BICO connection is made between two parameters, the 'unit' of the parameters (standardized (Hex) or physical (i.e. A) values) may differ. In this case an automatic conversion to the target value is made.

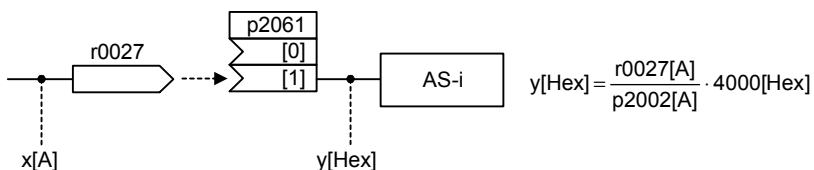

Note: Changes to P2002 result in a new calculation of P2004.

p2003[0...2]	Reference torque / Reference torque		
Access level: 3	Calculated: p0340 = 1	Data type: FloatingPoint32	
Can be changed: T	Scaling: -	Data set: DDS	
Min 0.10 [Nm]	Max 99999.00 [Nm]	Factory setting 0.75 [Nm]	
Description:	Full-scale reference torque used over the serial link (corresponds to 4000H).		
Example:	If a BICO connection is made between two parameters, the 'unit' of the parameters (standardized (Hex) or physical (i.e. Nm) values) may differ. In this case an automatic conversion to the target value is made.		

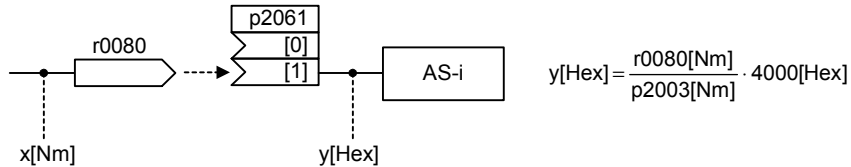

Note: Changes to P2003 result in a new calculation of P2004.

p2004[0...2]	Reference power / Reference power		
Access level: 3	Calculated: p0340 = 1	Data type: FloatingPoint32	
Can be changed: T	Scaling: -	Data set: DDS	
Min 0.01	Max 2000.00	Factory setting 0.75	
Description:	Full-scale reference power used over the serial link (corresponds to 4000H).		
Example:	If a BICO connection is made between two parameters, the 'unit' of the parameters (standardized (Hex) or physical (i.e. kW / hp) values) may differ. In this case an automatic conversion to the target value is made.		

p2010[0...1]	USS baudrate / USS baudrate		
Access level: 2	Calculated: -	Data type: Unsigned16	
Can be changed: U, T	Scaling: -	Data set: -	
Min 6	Max 12	Factory setting 8	
Description:	Sets baud rate for USS communication.		
Value:	6: 9600 baud 7: 19200 baud 8: 38400 baud 9: 57600 baud 10: 76800 baud 11: 93750 baud 12: 115200 baud		
Index:	[0] = reserved [1] = USS on RS232		

p2011[0...1]	USS address / USS address		
Access level: 2	Calculated: -	Data type: Unsigned16	
Can be changed: U, T	Scaling: -	Data set: -	
Min 0	Max 31	Factory setting 0	
Description:	Sets unique address for inverter.		
Index:	[0] = reserved [1] = USS on RS232		

p2012[0...1] USS PZD length / USS PZD length

Access level: 3	Calculated: -	Data type: Unsigned16
Can be changed: U, T	Scaling: -	Data set: -
Min 0	Max 8	Factory setting 2

Description: Defines the number of 16-bit words in PZD part of USS telegram.
In this area, process data (PZD) are continually exchanged between the master and slaves.
The PZD part of the USS telegram is used for the main setpoint, and to control the inverter.

Index: [0] = reserved
[1] = USS on RS232

Notice: USS protocol consists of PZD and PKW which can be changed by the user via parameters P2012 and P2013 respectively.

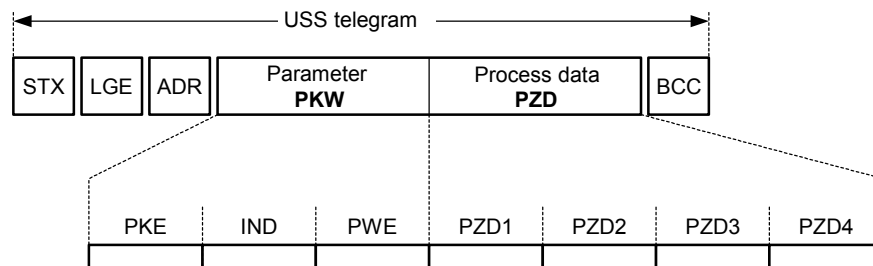

STX Start of text	PKE Parameter ID
LGE Length	IND Sub-index
ADR Address	PWE Parameter value
PKW Parameter ID value	
PZD Process data	
BCC Block check character	

PZD transmits a control word and setpoint or status word and actual values.

The number of PZD-words in a USS-telegram are determined by parameter P2012, where the first two words are either:

- a) control word and main setpoint or
- b) status word and actual value.

When P2012 is greater or equal to 4 the additional control word is transferred as the 4th PZD-word (default setting).

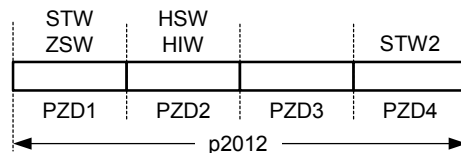

STW Control word	HSW Main setpoint
ZSW Status word	HIW Main actual value
PZD Process data	

p2013[0...1] USS PKW length / USS PKW length

Access level: 3	Calculated: -	Data type: Unsigned16
Can be changed: U, T	Scaling: -	Data set: -
Min 0	Max 127	Factory setting 127

Description: Defines the number of 16-bit words in PKW part of USS telegram.
The PKW area can be varied.
Depending on the particular requirement, 3-word, 4-word or variable word lengths can be parameterized.
The PKW part of the USS telegram is used to read and write individual parameter values.

Value:
 0: No words
 3: 3 words
 4: 4 words
 127: Variable

Example:

	Data type		
	U16 (16 Bit)	U32 (32 Bit)	Float (32 Bit)
p2013 = 3	X	Parameter access fault	Parameter access fault
p2013 = 4	X	X	X
p2013 = 127	X	X	X

Index:
 [0] = reserved
 [1] = USS on RS232

Notice: USS protocol consists of PZD and PKW which can be changed by the user via parameters P2012 and P2013 respectively.

Parameter P2013 determines the number of PKW-words in a USS-telegram.
 Setting P2013 to 3 or 4 determines the length of the PKW words (3 = three words and 4 = four words).
 When P2013 set to 127 automatically adjusts the length of the PKW words are required.

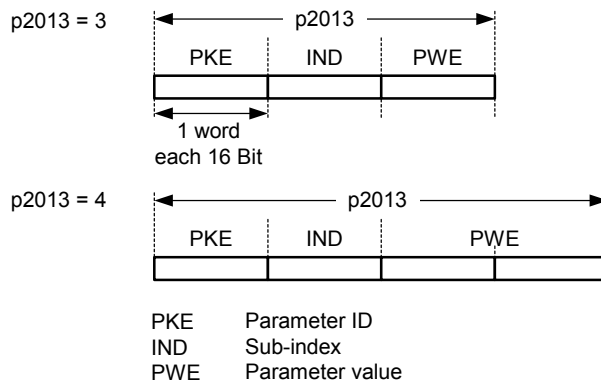

If a fixed PKW length is selected only one parameter value can be transferred.
 In the case of indexed parameter, you must use the variable PKW length if you wish to have the values of all indices transferred in a single telegram.
 In selecting the fixed PKW length, it is important to ensure the value in question can be transferred using this PKW length.
 P2013 = 3, fixes PKW length, but does not allow access to many parameter values.
 A parameter fault is generated when an out-of-range value is used, the value will not be accepted but the inverter state will not be affected.
 Useful for applications where parameters are not changed, but MM3s are also used.
 Broadcast mode is not possible with this setting.
 P2013 = 4, fixes PKW length.
 Allows access to all parameters, but indexed parameters can only be read one index at a time.
 Word order for single word values are different to setting 3 or 127, see example below.
 P2013 = 127, most useful setting.
 PKW reply length varies depending on the amount of information needed.
 Can read fault information and all indices of a parameter with a single telegram with this setting.

Example:
 Set P0700 to value 5 (0700 = 2BC (hex))

	p2013 = 3	p2013 = 4	p2013 = 127
Master → SINAMICS	22BC 0000 0006	22BC 0000 0000 0006	22BC 0000 0006 0000
SINAMICS → Master	12BC 0000 0006	12BC 0000 0000 0006	12BC 0000 0006

p2014[0...1] USS telegram off time / USS telegram T_off

Access level: 3	Calculated: -	Data type: Unsigned16
Can be changed: T	Scaling: -	Data set: -
Min 0 [ms]	Max 65535 [ms]	Factory setting 0 [ms]

Description: Index 0 Unused
Index 1 defines a time T_off after which a fault will be generated (F0071) if no telegram is received via the USS channel RS232.

Index: [0] = reserved
[1] = USS on RS232

Notice: By default (time set to 0), no fault is generated (i.e. watchdog disabled).

r2015[0...7] CO: PZD from USS on RS232 / PZD<-USS

Access level: 3	Calculated: -	Data type: Unsigned16
Unit: -	Scaling: 4000H	Data set: -

Description: Displays process data received via USS on RS232.

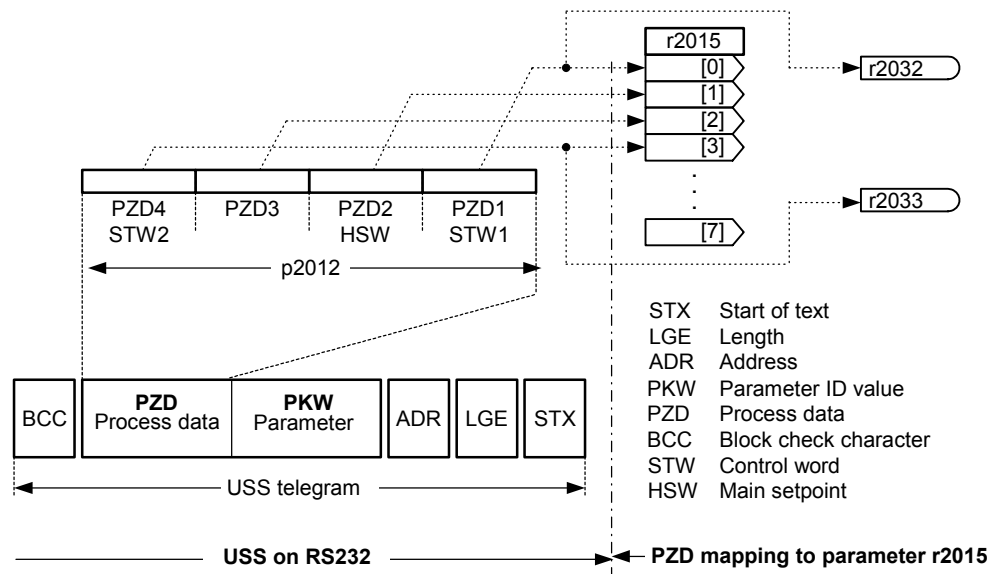

Index: [0] = Received word 0
[1] = Received word 1
[2] = Received word 2
[3] = Received word 3
[4] = Received word 4
[5] = Received word 5
[6] = Received word 6
[7] = Received word 7

Note: The control words can be viewed as bit parameters r2032 and r2033.

Restrictions:

- If the above serial interface controls the inverter (P0700 or P0719) then the 1st control word must be transferred in the 1st PZD-word.
- If the setpoint source is selected via P1000 or P0719, then the main setpoint must be transferred in the 2nd PZD-word,
- When P2012 is greater than or equal to 4 the additional control word (2nd control word) must transferred in the 4th PZD-word, if the above serial interface controls the inverter (P0700 or P0719).

p2016[0...7]	CI: PZD to USS on RS232 / PZD->USS	
Access level: 3	Calculated: -	Data type: U32 / Integer16
Can be changed: T	Scaling: 4000H	Data set: -
Min	Max	Factory setting
-	-	[0] 52[0]
		[1] 21[0]
		[2] 0
		[3] 53[0]
		[4...7] 0

Description: Selects signals to be transmitted to serial interface via USS on RS232.

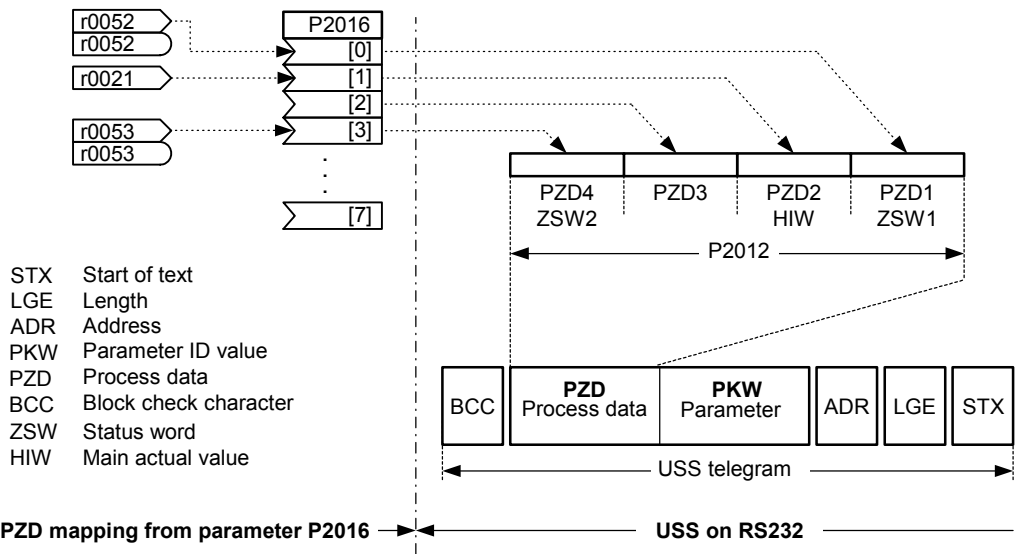

This parameter defines the source of the status words and actual values for the reply PZD.

Index 0 cannot be changed and contains always statusword 1.

Example: P2016[0] = 52.0 (default). In this case, the value of r0052 (CO/BO: Status word) is transmitted as 1st PZD to the USS on RS232.

Index:

- [0] = Transmitted word 0
- [1] = Transmitted word 1
- [2] = Transmitted word 2
- [3] = Transmitted word 3
- [4] = Transmitted word 4
- [5] = Transmitted word 5
- [6] = Transmitted word 6
- [7] = Transmitted word 7

Note: If r0052 not indexed, display does not show an index (".0").

p2021[0...1]	ASI slave address / ASI slave address		
	Access level: 2	Calculated: -	Data type: Unsigned16
	Can be changed: T	Scaling: -	Data set: -
	Min 0	Max 63	Factory setting 0
Description:	Defines ASI address for slaves. Dual slave: - P2021[0]: address for slave 1, profile 7.A.5 - P2021[1]: address for slave 2, Profile 7.A.E Single slave: - P2021[0]: reserved - P2021[1]: address for slave 2, Profile 7.F.E These ways to set the slave address: 1. via handheld programmer 2. via a user-entered value 3. via ASI master		
Index:	[0] = Address Slave 1 [1] = Address Slave 2		
Note:	Possible address settings: Dual slave: 0 ... 31 for A address 33 ... 63 for B address Single slave: 0 ... 31 for A address After this parameter is changed, the inverter will perform ASI reset in order to load the new addresses.		

p2022	ASI slave select / ASI slave select		
	Access level: 3	Calculated: -	Data type: Unsigned16
	Can be changed: T	Scaling: -	Data set: -
	Min 0	Max 2	Factory setting 2
Description:	Selects single slave or dual slave.		
Value:	0: Single slave without AB addressing 2: Dual slave with AB addressing		
Note:	After this parameter is changed, the inverter will perform ASI reset in order to load the new profile information. Slave address will be reset to 0.		

p2023[0...1]	ASI slave profile / ASI slave profile		
	Access level: 3	Calculated: -	Data type: Unsigned16
	Can be changed: T	Scaling: -	Data set: -
	Min 0	Max 15	Factory setting 0
Description:	Defines ID1 profile for slaves. Dual slave: - P2021[0]: ID1 for slave 1, profile 7.A.5 - P2021[1]: ID1 for slave 2, profile 7.A.E Single slave: - P2021[0]: = reserved - P2021[1]: = ID1 for slave 2, profile 7.F.E		

These ways to set the ID1 profile:

1. via handheld programmer
2. via a user-entered value
3. via ASI master

Index: [0] = ID1 Slave 1
[1] = ID1 Slave 2

Note: Possible ID1 profile settings:

- 0 ... 7 for dual slave
0 ... 15 for single slave

After this parameter is changed, the inverter will perform ASI reset in order to load the new ID1 profile information.

r2024[0...1]	USS error-free telegrams / USS error-free tel		
	Access level: 3	Calculated: -	Data type: Unsigned16
	Unit: -	Scaling: -	Data set: -
Description:	Displays number of error-free USS telegrams received.		
Index:	[0] = reserved [1] = USS on RS232		

r2025[0...1]	USS rejected telegrams / USS rejected tel.		
	Access level: 3	Calculated: -	Data type: Unsigned16
	Unit: -	Scaling: -	Data set: -
Description:	Displays number of USS telegrams rejected.		
Index:	[0] = reserved [1] = USS on RS232		

r2026[0...1]	USS character frame error / USS char.frame err		
	Access level: 3	Calculated: -	Data type: Unsigned16
	Unit: -	Scaling: -	Data set: -
Description:	Displays number of USS character frame errors.		
Index:	[0] = reserved [1] = USS on RS232		

r2027[0...1]	USS overrun error / USS overrun error		
	Access level: 3	Calculated: -	Data type: Unsigned16
	Unit: -	Scaling: -	Data set: -
Description:	Displays number of USS telegrams with overrun error.		
Index:	[0] = reserved [1] = USS on RS232		

r2028[0...1]	USS parity error / USS parity error		
	Access level: 3	Calculated: -	Data type: Unsigned16
	Unit: -	Scaling: -	Data set: -
Description:	Displays number of USS telegrams with parity error.		
Index:	[0] = reserved [1] = USS on RS232		

r2029[0...1]	USS start not identified / USS start unident.		
	Access level: 3	Calculated: -	Data type: Unsigned16
	Unit: -	Scaling: -	Data set: -
Description:	Displays number of USS telegrams with unidentified start.		
Index:	[0] = reserved [1] = USS on RS232		

r2030[0...1]	USS BCC error / USS BCC error				
	Access level: 3	Calculated: -	Data type: Unsigned16		
	Unit: -	Scaling: -	Data set: -		
Description:	Displays number of USS telegrams with BCC error.				
Index:	[0] = reserved [1] = USS on RS232				
r2031[0...1]	USS length error / USS length error				
	Access level: 3	Calculated: -	Data type: Unsigned16		
	Unit: -	Scaling: -	Data set: -		
Description:	Displays number of USS telegrams with incorrect length.				
Index:	[0] = reserved [1] = USS on RS232				
r2032.0...15	BO: CtrlWrd1 from USS on RS232 / CtrlWd1 <- USS				
	Access level: 3	Calculated: -	Data type: Unsigned16		
	Unit: -	Scaling: -	Data set: -		
Description:	Displays control word 1 from USS on RS232 (word 1 within USS).				
Bit field:	Bit	Signal name	1 signal	0 signal	FP
	00	ON/OFF1	Yes	No	-
	01	OFF2: Electrical stop	No	Yes	-
	02	OFF3: Fast stop	No	Yes	-
	03	Pulse enable	Yes	No	-
	04	RFG enable	Yes	No	-
	05	RFG start	Yes	No	-
	06	Setpoint enable	Yes	No	-
	07	Fault acknowledge	Yes	No	-
	08	JOG right	Yes	No	-
	09	JOG left	Yes	No	-
	10	Control from PLC	Yes	No	-
	11	Reverse (setpoint inversion)	Yes	No	-
	13	Motor potentiometer MOP up	Yes	No	-
	14	Motor potentiometer MOP down	Yes	No	-
	15	CDS Bit 0 (Hand/Auto)	Yes	No	-
r2033.0...15	BO: CtrlWrd2 from USS on RS232 / CtrlWd2 <- USS				
	Access level: 3	Calculated: -	Data type: Unsigned16		
	Unit: -	Scaling: -	Data set: -		
Description:	Displays control word 2 from USS on RS232 (i.e. word 4 within USS).				
Bit field:	Bit	Signal name	1 signal	0 signal	FP
	00	Fixed frequency Bit 0	Yes	No	-
	01	Fixed frequency Bit 1	Yes	No	-
	02	Fixed frequency Bit 2	Yes	No	-
	03	Fixed frequency Bit 3	Yes	No	-
	04	Drive Dataset (DDS) Bit 0	Yes	No	-
	05	Drive Dataset (DDS) Bit 1	Yes	No	-
	06	Quick Stop disable	Yes	No	-
	08	Enable PID	Yes	No	-
	09	Enable DC brake	Yes	No	-
	13	External fault 1	No	Yes	-
	15	Command Dataset (CDS) Bit 1	Yes	No	-
Dependency:	P0700 = 4 (USS on RS232) and P0719 = 0 (Cmd / Setpoint = BICO parameter).				

p2038	Selection of actual profile / Actual profile		
	Access level: 3	Calculated: -	Data type: Unsigned16
	Can be changed: T	Scaling: -	Data set: -
	Min 0	Max 3	Factory setting 0
Value:	0: PROFIdrive Profile 2: Namur 3: reserved		
p2040	Fieldbus telegram off time / FB tel. off time		
	Access level: 3	Calculated: -	Data type: Unsigned16
	Can be changed: T	Scaling: -	Data set: -
	Min 0 [ms]	Max 65535 [ms]	Factory setting 500 [ms]
Description:	Defines time after which a fault will be generated (F0070) if no telegram is received via the link.		
Dependency:	Setting 0 = watchdog disabled		
r2053[0...7]	FB identification / FB identification		
	Access level: 3	Calculated: -	Data type: Unsigned16
	Unit: -	Scaling: -	Data set: -
Description:	Displays identification data of the communication. 2053[0]: = 0 = No communication option available 2053[0]: = 1 = PROFIBUS DP 2053[0]: = 2 = DeviceNet 2053[0]: = 3 = CAN 2053[0]: = 4 = AS-i 2053[0]: = 5 = LON 2053[0]: = 6 = Modbus 2053[0]: = 10 = PROFINET IO 2053[0]: = 11 = ES bus (ET200pro) 2053[0]: = 4660 = ES bus (ET200s) 2053[0]: = 65535 = not defined 2053[1]: firmware version (major and minor each with 2 digits) 2053[2]: firmware version detail (release and build each with 2 digits) 2053[3]: firmware date (year with century) 2053[4]: firmware date (day and month each with 2 digits) 2053[5]: datastructure version 2053[6]: driver version 2053[7]: company ID (42 = SIEMENS)		
Index:	[0] = Fieldbus type [1] = FW version [2...6] = Unused [7] = company ID		
r2059[0...4]	CO: Displays SOL link stats for Sol Master / Disp SOL stats		
	Access level: 4	Calculated: -	Data type: Unsigned16
	Unit: -	Scaling: -	Data set: -
Description:	Displays SOL link stats for Sol Master.		
Index:	[0] = messages txd [1] = valid messages rxd [2] = crc errors [3] = stx errors [4] = ASI Master Exists		

p2061[0...1]	CI: CTT2 data to ASI / CTT2 data to ASI				
	Access level: 3	Calculated: -	Data type: U32 / Integer16		
	Can be changed: T	Scaling: 4000H	Data set: -		
	Min	Max	Factory setting		
	-	-	[0] 21[0] [1] 27[0]		
Description:	CTT2 data sent to ASI master.				
Index:	[0] = Transmitted word 0 [1] = Transmitted word 1				
r2062[0...1]	CO: CTT2 from ASI / CTT2 from ASI				
	Access level: 3	Calculated: -	Data type: Unsigned16		
	Unit: -	Scaling: 4000H	Data set: -		
Description:	CTT2 data from ASI master.				
Index:	[0] = Received word 0 [1] = Received word 1				
p2063[0...5]	BI: ASI DigIn / ASI DigIn				
	Access level: 3	Calculated: -	Data type: U32 / Binary		
	Can be changed: T	Scaling: -	Data set: -		
	Min	Max	Factory setting		
	-	-	[0] 53.13 [1] 56.2 [2] 2067.0 [3] 2067.1 [4] 2067.2 [5] 2067.3		
Description:	ASI master digital inputs for slave 1 and slave 2.				
Index:	[0] = ASI DI0 Slave 2 [1] = ASI DI1 Slave 2 [2] = ASI DI2 Slave 2 [3] = ASI DI3 Slave 2 [4] = ASI DI0 Slave 1 [5] = ASI DI1 Slave 1				
r2067.0...11	CO/BO: Digital input values Status / Dig.inp.val				
	Access level: 3	Calculated: -	Data type: Unsigned16		
	Unit: -	Scaling: -	Data set: -		
Description:	Displays status of digital inputs.				
Bit field:	Bit	Signal name	1 signal	0 signal	FP
	00	Digital input 0	Yes	No	-
	01	Digital input 1	Yes	No	-
	02	Digital input 2	Yes	No	-
	03	Digital input 3	Yes	No	-
	11	Digital input AI0	Yes	No	-
Note:	This is used for bico connection without software intervention.				

r2090.0...15	BO: Control word 1 from Fieldbus / CtrlWd1 <- FB				
	Access level: 3	Calculated: -	Data type: Unsigned16		
	Unit: -	Scaling: -	Data set: -		
Description:	Displays control word 1 received from Fieldbus.				
Bit field:	Bit	Signal name	1 signal	0 signal	FP
	00	ON/OFF1	Yes	No	-
	01	OFF2: Electrical stop	No	Yes	-
	02	OFF3: Fast stop	No	Yes	-
	03	Pulse enable	Yes	No	-
	04	RFG enable	Yes	No	-
	05	RFG start	Yes	No	-
	06	Setpoint enable	Yes	No	-
	07	Fault acknowledge	Yes	No	-
	08	JOG right	Yes	No	-
	09	JOG left	Yes	No	-
	10	Control from PLC	Yes	No	-
	11	Reverse (setpoint inversion)	Yes	No	-
	13	Motor potentiometer MOP up	Yes	No	-
	14	Motor potentiometer MOP down	Yes	No	-
	15	CDS Bit 0 (Hand/Auto)	Yes	No	-
Note:	If P0700 = 6 (Fieldbus) then P0810 must be set to 2090.15 for correct operation. This will not be cleared automatically when P0700 is no longer equal to 6.				
r2091.0...15	BO: Control word 2 from Fieldbus / CtrlWd2 <- FB				
	Access level: 3	Calculated: -	Data type: Unsigned16		
	Unit: -	Scaling: -	Data set: -		
Description:	Displays control word 2 received from Fieldbus.				
Bit field:	Bit	Signal name	1 signal	0 signal	FP
	00	Fixed frequency Bit 0	Yes	No	-
	01	Fixed frequency Bit 1	Yes	No	-
	02	Fixed frequency Bit 2	Yes	No	-
	03	Fixed frequency Bit 3	Yes	No	-
	04	Drive Dataset (DDS) Bit 0	Yes	No	-
	05	Drive Dataset (DDS) Bit 1	Yes	No	-
	06	Quick Stop disable	Yes	No	-
	08	Enable PID	Yes	No	-
	09	Enable DC brake	Yes	No	-
	13	External fault 1	No	Yes	-
	15	Command Dataset (CDS) Bit 1	Yes	No	-
p2100[0...2]	Alarm number selection / Alarm No selection				
	Access level: 3	Calculated: -	Data type: Unsigned16		
	Can be changed: T	Scaling: -	Data set: -		
	Min	Max	Factory setting		
	0	65535	0		
Description:	Selects up to 3 faults or warnings for non-default reactions.				
Example:	If, for example, an OFF3 is to be carried out instead of an OFF2 for a fault, the fault number has to be entered in P2100 and the desired reaction selected in P2101 (in this case (OFF3) P2101 = 3).				
Index:	[0] = Fault Number 1 [1] = Fault Number 2 [2] = Fault Number 3				
Note:	All fault codes have a default reaction to OFF2. Some fault codes caused by hardware trips (e.g. overcurrent) cannot be changed from the default reactions.				

p2101[0...2]	Stop reaction value / Stop reaction val.		
	Access level: 3	Calculated: -	Data type: Unsigned16
	Can be changed: T	Scaling: -	Data set: -
	Min 0	Max 4	Factory setting 0
Description:	Sets drive stop reaction values for faults selected by P2100 (alarm number selection). This indexed parameter specifies the special reaction to the faults/warnings defined in P2100 indices 0 to 2.		
Value:	0: No reaction, no display 1: OFF1 stop reaction 2: OFF2 stop reaction 3: OFF3 stop reaction 4: No reaction warning only		
Index:	[0] = Stop reaction value 1 [1] = Stop reaction value 2 [2] = Stop reaction value 3		
Note:	Settings 1 - 3 are only available for fault codes. Setting 4 is only available for warnings. Index 0 (P2101) refers to fault/warning in index 0 (P2100).		
p2103[0...2]	BI: 1. Faults acknowledgement / 1. Faults ackn		
	Access level: 3	Calculated: -	Data type: U32 / Binary
	Can be changed: T	Scaling: -	Data set: CDS
	Min -	Max -	Factory setting 722.2
Description:	Defines first source of fault acknowledgement.		
p2104[0...2]	BI: 2. Faults acknowledgement / 2. Faults ackn		
	Access level: 3	Calculated: -	Data type: U32 / Binary
	Can be changed: T	Scaling: -	Data set: CDS
	Min -	Max -	Factory setting 2090.7
Description:	Selects second source of fault acknowledgement.		
p2106[0...2]	BI: External fault / External fault		
	Access level: 3	Calculated: -	Data type: U32 / Binary
	Can be changed: T	Scaling: -	Data set: CDS
	Min -	Max -	Factory setting 1
Description:	Selects source of external faults.		
r2110[0...3]	CO: Warning number / Warning number		
	Access level: 2	Calculated: -	Data type: Unsigned16
	Unit: -	Scaling: -	Data set: -
Description:	Displays warning information. A maximum of 2 active warnings (indices 0 and 1) and 2 historical warnings (indices 2 and 3) may be viewed.		
Index:	[0] = Recent Warnings --, warning 1 [1] = Recent Warnings --, warning 2 [2] = Recent Warnings -1, warning 3 [3] = Recent Warnings -1, warning 4		
Notice:	Indices 0 and 1 are not stored.		

p2111	Total number of warnings / Total no. warnings														
	Access level: 3	Calculated: -	Data type: Unsigned16												
	Can be changed: T	Scaling: -	Data set: -												
	Min 0	Max 4	Factory setting 0												
Description:	Displays number of warning (up to 4) since last reset. Set to 0 to reset the warning history.														
r2114[0...1]	Run time counter / Run time counter														
	Access level: 3	Calculated: -	Data type: Unsigned16												
	Unit: -	Scaling: -	Data set: -												
Description:	Displays run time counter. It is the total time the drive has been powered up. When power is switched off, the value is saved, then restored on powerup. The run time counter will be calculate as followed: Multiply the value in r2114[0] by 65536 and then add it to the value in r2114[1]. The resultant answer will be in seconds. This means that r2114[0] is not days. Total powerup time = 65536 * r2114[0] + r2114[1] seconds.														
Example:	If r2114[0] = 1 and r2114[1] = 20864 We get 1 * 65536 + 20864 = 86400 seconds which equals 1 day.														
Index:	[0] = System Time, Seconds, Upper Word [1] = System Time, Seconds, Lower Word														
Note:	When the real time is not given in P2115, the time in this parameter is used by r0948 to indicate when a fault has occurred. See r0948 (fault time).														
p2115[0...2]	Real time clock / Real time clk														
	Access level: 4	Calculated: -	Data type: Unsigned16												
	Can be changed: T	Scaling: -	Data set: -												
	Min 0	Max 65535	Factory setting 257												
Description:	Displays real time. All inverters require an on-board clock function with which fault conditions may be timestamped and logged. However, they have no battery backed Real Time Clock (RTC). Inverters may support a software driven RTC which requires synchronisation with the RTC supplied via a serial interface. The time is stored in a word array parameter P2115. The time will be set by USS Protocol standard "word array parameter write" telegrams. Once the last word is received in index 2, the software will start running the timer itself using internal running 1 millisecond tic. Hence becoming like RTC. If powercycle takes place, then the real time must be sent again to the inverter. Time is maintained in a word array parameter and encoded as follows - the same format will be used in fault report logs.														
	<table border="1"> <thead> <tr> <th>Index</th> <th>High Byte (MSB)</th> <th>Low Byte (LSB)</th> </tr> </thead> <tbody> <tr> <td>0</td> <td>Seconds (0 - 59)</td> <td>Minutes (0 - 59)</td> </tr> <tr> <td>1</td> <td>Hours (0 - 23)</td> <td>Days (1 - 31)</td> </tr> <tr> <td>2</td> <td>Month (1 - 12)</td> <td>Years (00 - 250)</td> </tr> </tbody> </table>			Index	High Byte (MSB)	Low Byte (LSB)	0	Seconds (0 - 59)	Minutes (0 - 59)	1	Hours (0 - 23)	Days (1 - 31)	2	Month (1 - 12)	Years (00 - 250)
Index	High Byte (MSB)	Low Byte (LSB)													
0	Seconds (0 - 59)	Minutes (0 - 59)													
1	Hours (0 - 23)	Days (1 - 31)													
2	Month (1 - 12)	Years (00 - 250)													
	The values are in binary form.														
Index:	[0] = Real Time, Seconds+Minutes [1] = Real Time, Hours+Days [2] = Real Time, Month+Year														
Note:	See r0948 (fault time).														

p2120	Indication counter / Indication counter		
	Access level: 4	Calculated: -	Data type: Unsigned16
	Can be changed: U, T	Scaling: -	Data set: -
	Min 0	Max 65535	Factory setting 0
Description:	Indicates total number of fault/warning events. This parameter is incremented whenever an fault/warning event occurs. This parameter is used by the PC tools.		
p2150[0...2]	Hysteresis frequency f_hys / Hyst. freq. f_hys		
	Access level: 3	Calculated: -	Data type: FloatingPoint32
	Can be changed: U, T	Scaling: -	Data set: DDS
	Min 0.00 [Hz]	Max 10.00 [Hz]	Factory setting 3.00 [Hz]
Description:	Defines hysteresis level applied for comparing frequency and speed to threshold.		
Dependency:	See function diagram 4100.		
p2151[0...2]	Cl: Speed setpoint for messages / n-Set for msg		
	Access level: 2	Calculated: -	Data type: U32 / Integer32
	Can be changed: U, T	Scaling: -	Data set: DDS
	Min -	Max -	Factory setting 1170[0]
Description:	Selects the source of setpoint frequency, actual frequency is compared with this frequency to detect frequency deviation (see monitoring bit r2197.7).		
p2155[0...2]	Threshold frequency f_1 / Threshold freq f_1		
	Access level: 3	Calculated: -	Data type: FloatingPoint32
	Can be changed: U, T	Scaling: -	Data set: DDS
	Min 0.00 [Hz]	Max 650.00 [Hz]	Factory setting 30.00 [Hz]
Description:	Sets a threshold for comparing actual speed or frequency to threshold values f_1. This threshold controls status bits 4 and 5 in status word 2 (r0053).		
Dependency:	See function diagram 4100.		
p2156[0...2]	Delay time of threshold freq f_1 / Delay time of f_1		
	Access level: 3	Calculated: -	Data type: Unsigned16
	Can be changed: U, T	Scaling: -	Data set: DDS
	Min 0 [ms]	Max 10000 [ms]	Factory setting 10 [ms]
Description:	Sets delay time prior to threshold frequency f_1 comparison (P2155).		
p2162[0...2]	Hysteresis freq. for overspeed / Overspd. hyst.freq		
	Access level: 2	Calculated: -	Data type: FloatingPoint32
	Can be changed: U, T	Scaling: -	Data set: DDS
	Min 0.00 [Hz]	Max 25.00 [Hz]	Factory setting 3.00 [Hz]
Description:	Hysteresis speed (frequency) for overspeed detection. For V/f control modes the hysteresis acts below the max. frequency.		
Dependency:	See function diagram 4110.		

p2164[0...2]	Hysteresis frequency deviation / Hyster freq deviat		
	Access level: 3	Calculated: -	Data type: FloatingPoint32
	Can be changed: U, T	Scaling: -	Data set: DDS
	Min 0.00 [Hz]	Max 10.00 [Hz]	Factory setting 3.00 [Hz]
Description:	Hysteresis frequency for detecting permitted deviation (from setpoint) or frequency or speed. This frequency controls bit 8 in status word 1 (r0052).		
p2166[0...2]	Delay time ramp up completed / Delay_T rampUpCmpl		
	Access level: 2	Calculated: -	Data type: Unsigned16
	Can be changed: U, T	Scaling: -	Data set: DDS
	Min 0 [ms]	Max 10000 [ms]	Factory setting 10 [ms]
Description:	Delay time for signal that indicates completion of ramp-up.		
p2167[0...2]	Switch-off frequency f_off / SwOff freq. f_off		
	Access level: 3	Calculated: -	Data type: FloatingPoint32
	Can be changed: U, T	Scaling: -	Data set: DDS
	Min 0.00 [Hz]	Max 10.00 [Hz]	Factory setting 1.00 [Hz]
Description:	Defines the threshold of the monitoring function $ f_{act} > P2167 (f_{off})$. P2167 influences following functions: <ul style="list-style-type: none"> • If the actual frequency falls below this threshold and the time delay has expired, bit 1 in status word 2 (r0053) is reset. • If a OFF1 or OFF3 was applied and bit 1 is reset the inverter will disable the pulse (OFF2). 		
Dependency:	See function diagram 4110.		
p2168[0...2]	Delay time T_off / Delay time T_off		
	Access level: 3	Calculated: -	Data type: Unsigned16
	Can be changed: U, T	Scaling: -	Data set: DDS
	Min 0 [ms]	Max 10000 [ms]	Factory setting 10 [ms]
Description:	Defines time for which the inverter may operate below switch-off frequency (P2167) before switch off occurs.		
Dependency:	Active if holding brake (P1215) not parameterized.		
p2170[0...2]	Threshold current I_thresh / Threshold current		
	Access level: 3	Calculated: -	Data type: FloatingPoint32
	Can be changed: U, T	Scaling: -	Data set: DDS
	Min 0.0 [%]	Max 400.0 [%]	Factory setting 100.0 [%]
Description:	Defines threshold current in [%] relative to P0305 (rated motor current) to be used in comparisons of I_act and I_Thresh. This threshold controls bit 3 in status word 3 (r0053).		
Dependency:	See function diagram 4110.		

p2171[0...2]	Delay time current / Delay time current		
	Access level: 3	Calculated: -	Data type: Unsigned16
	Can be changed: U, T	Scaling: -	Data set: DDS
	Min 0 [ms]	Max 10000 [ms]	Factory setting 10 [ms]
Description:	Defines delay time prior to activation of current comparison.		
p2172[0...2]	Threshold DC-link voltage / Vdc threshold		
	Access level: 3	Calculated: -	Data type: Unsigned16
	Can be changed: U, T	Scaling: -	Data set: DDS
	Min 0 [V]	Max 2000 [V]	Factory setting 800 [V]
Description:	Defines DC link voltage to be compared to actual voltage. This voltage controls bits 7 and 8 in status word 3 (r0053).		
Dependency:	See function diagram 4115.		
p2173[0...2]	Delay time DC-link voltage / Vdc delay time		
	Access level: 3	Calculated: -	Data type: Unsigned16
	Can be changed: U, T	Scaling: -	Data set: DDS
	Min 0 [ms]	Max 10000 [ms]	Factory setting 10 [ms]
Description:	Defines delay time prior to activation of threshold comparison.		
p2177[0...2]	Delay time for motor is blocked / Delay_T MotBlocked		
	Access level: 2	Calculated: -	Data type: Unsigned16
	Can be changed: U, T	Scaling: -	Data set: DDS
	Min 0 [ms]	Max 10000 [ms]	Factory setting 10 [ms]
Description:	Delay time for identification that motor is blocked.		
p2179	Current limit for no load ident. / Cur.lim:no-load ID		
	Access level: 3	Calculated: -	Data type: FloatingPoint32
	Can be changed: U, T	Scaling: -	Data set: -
	Min 0.0 [%]	Max 10.0 [%]	Factory setting 3.0 [%]
Description:	Threshold current for A0922 (load missing) in [%] relative to P0305 (rated motor current).		
Dependency:	See function diagram 4110.		
Notice:	If a motor setpoint cannot be entered and the current limit (P2179) is not exceeded, warning A0922 (no load applied) is issued when delay time (P2180) expires.		
Note:	It may be that the motor is not connected (load missing) or a phase could be missing.		
p2180	Delay time for load missing / Load missing delay		
	Access level: 3	Calculated: -	Data type: Unsigned16
	Can be changed: U, T	Scaling: -	Data set: -
	Min 0 [ms]	Max 10000 [ms]	Factory setting 2000 [ms]
Description:	Delay time load missing		

p2181[0...2]	Belt failure detection mode / Belt fail detect		
	Access level: 2	Calculated: -	Data type: Unsigned16
	Can be changed: T	Scaling: -	Data set: DDS
	Min 0	Max 6	Factory setting 0
Description:	Sets belt failure detection mode. This function allows detection of mechanical failure of the drive train, e.g. a broken drive belt. It can also detect conditions which cause an overload, such as a jam. Parameters P2182 - P2190 are set to default when this parameter is changed from 0. This is achieved by comparing the actual frequency/torque curve with a programmed envelope (see P2182 - P2190). If the curve falls outside the envelope, a warning or trip is generated.		
Value:	0: Belt failure detection disabled 1: Warning: Low torque / speed 2: Warning: High torque / speed 3: Warning: High / low torque / speed 4: Trip: Low torque / speed 5: Trip: High torque / speed 6: Trip: High / low torque / speed		
p2182[0...2]	Belt threshold frequency 1 / Belt threshold f_1		
	Access level: 3	Calculated: -	Data type: FloatingPoint32
	Can be changed: U, T	Scaling: -	Data set: DDS
	Min 0.00 [Hz]	Max 650.00 [Hz]	Factory setting 5.00 [Hz]
Description:	Sets the lower frequency threshold f_1 for defining the area where the belt failure detection is effective. The frequency torque envelope is defined by 9 parameters - 3 are frequency parameters (P2182 - P2184), and the other 6 define the low and high torque limits (P2185 - P2190) for each frequency.		
Note:	Below the threshold in p2182 and above the threshold in p2184, belt failure detection mode is not active.		
p2183[0...2]	Belt threshold frequency 2 / Belt threshold f_2		
	Access level: 2	Calculated: -	Data type: FloatingPoint32
	Can be changed: U, T	Scaling: -	Data set: DDS
	Min 0.00 [Hz]	Max 650.00 [Hz]	Factory setting 30.00 [Hz]
Description:	Sets the frequency threshold f_2 for defining the envelope in which the torque values are valid.		
p2184[0...2]	Belt threshold frequency 3 / Belt threshold f_3		
	Access level: 2	Calculated: -	Data type: FloatingPoint32
	Can be changed: U, T	Scaling: -	Data set: DDS
	Min 0.00 [Hz]	Max 650.00 [Hz]	Factory setting 50.00 [Hz]
Description:	Sets the upper frequency threshold f_3 for defining the area where the belt failure detection is effective.		
p2185[0...2]	Upper torque threshold 1 / Upper trq. thresh1		
	Access level: 2	Calculated: p0340 = 1	Data type: FloatingPoint32
	Can be changed: U, T	Scaling: -	Data set: DDS
	Min 0.0 [Nm]	Max 99999.0 [Nm]	Factory setting 99999.0 [Nm]
Description:	Upper limit threshold value 1 for comparing actual torque.		
Note:	The factory setting depends on rating data of Power Module and Motor.		

p2186[0...2]	Lower torque threshold 1 / Lower trq. thresh1		
	Access level: 2	Calculated: -	Data type: FloatingPoint32
	Can be changed: U, T	Scaling: -	Data set: DDS
	Min 0.0 [Nm]	Max 99999.0 [Nm]	Factory setting 0.0 [Nm]
Description:	Lower limit threshold value 1 for comparing actual torque.		
p2187[0...2]	Upper torque threshold 2 / Upper trq. thresh2		
	Access level: 2	Calculated: p0340 = 1	Data type: FloatingPoint32
	Can be changed: U, T	Scaling: -	Data set: DDS
	Min 0.0 [Nm]	Max 99999.0 [Nm]	Factory setting 99999.0 [Nm]
Description:	Upper limit threshold value 2 for comparing actual torque.		
Note:	The factory setting depends on rating data of Power Module and Motor.		
p2188[0...2]	Lower torque threshold 2 / Lower trq. thresh2		
	Access level: 2	Calculated: -	Data type: FloatingPoint32
	Can be changed: U, T	Scaling: -	Data set: DDS
	Min 0.0 [Nm]	Max 99999.0 [Nm]	Factory setting 0.0 [Nm]
Description:	Lower limit threshold value 2 for comparing actual torque.		
p2189[0...2]	Upper torque threshold 3 / Upper trq. thresh3		
	Access level: 2	Calculated: p0340 = 1	Data type: FloatingPoint32
	Can be changed: U, T	Scaling: -	Data set: DDS
	Min 0.0 [Nm]	Max 99999.0 [Nm]	Factory setting 99999.0 [Nm]
Description:	Upper limit threshold value 3 for comparing actual torque.		
Note:	The factory setting depends on rating data of Power Module and Motor.		
p2190[0...2]	Lower torque threshold 3 / Lower trq. thresh3		
	Access level: 2	Calculated: -	Data type: FloatingPoint32
	Can be changed: U, T	Scaling: -	Data set: DDS
	Min 0.0 [Nm]	Max 99999.0 [Nm]	Factory setting 0.0 [Nm]
Description:	Lower limit threshold value 3 for comparing actual torque.		
p2192[0...2]	Time delay for belt failure / Belt fail delay_T		
	Access level: 2	Calculated: -	Data type: Unsigned16
	Can be changed: U, T	Scaling: -	Data set: DDS
	Min 0 [s]	Max 65 [s]	Factory setting 10 [s]
Description:	P2192 defines a delay before warning/trip becomes active. - It is used to eliminate events caused by transient conditions. - It is used for both methods of fault detection.		

r2197.0...12		CO/BO: Monitoring word 1 / Monitor Wd1			
	Access level: 2	Calculated: -	Data type: Unsigned16		
	Unit: -	Scaling: -	Data set: -		
Description:	Monitoring word 1 which indicates the state of monitor functions. Each bit represents one monitor function.				
Bit field:	Bit	Signal name	1 signal	0 signal	FP
	00	f_act <= P1080 (f_min)	Yes	No	-
	01	f_act <= P2155 (f_1)	Yes	No	-
	02	f_act > P2155 (f_1)	Yes	No	-
	03	f_act >= zero	Yes	No	-
	04	f_act >= setp. (f_set)	Yes	No	-
	05	f_act <= P2167 (f_off)	Yes	No	-
	06	f_act >= P1082 (f_max)	Yes	No	-
	07	f_act == setp. (f_set)	Yes	No	-
	08	Act. current r0068 >= P2170	Yes	No	-
	09	Act. unfilt. Vdc < P2172	Yes	No	-
	10	Act. unfilt. Vdc > P2172	Yes	No	-
	11	Load missing	Yes	No	-
	12	f_act > P1082 with delay	Yes	No	-
Note:	See function diagrams 4100 and 4110.				

r2198.0...12		CO/BO: Monitoring word 2 / Monitor Wd2			
	Access level: 2	Calculated: -	Data type: Unsigned16		
	Unit: -	Scaling: -	Data set: -		
Description:	Monitoring word 2 which indicates the state of monitor functions. Each bit represents one monitor function.				
Bit field:	Bit	Signal name	1 signal	0 signal	FP
	00	Unused	Yes	No	-
	01	Unused	Yes	No	-
	02	Unused	Yes	No	-
	03	Unused	Yes	No	-
	04	Unused	Yes	No	-
	05	f_set > 0	Yes	No	-
	06	Motor blocked	Yes	No	-
	07	Motor pulled out	Yes	No	-
	08	_act r0068 < P2170	Yes	No	-
	09	Unused	Yes	No	-
	10	Unused	Yes	No	-
	11	Belt failure warning	Yes	No	-
	12	Belt failure trip	Yes	No	-

p2200[0...2]		BI: Enable PID controller / Enab. PID ctrl		
	Access level: 2	Calculated: -	Data type: U32 / Binary	
	Can be changed: U, T	Scaling: -	Data set: CDS	
	Min	Max	Factory setting	
	-	-	0	
Description:	Allows user to enable/disable the PID controller. Setting to 1 enables the PID closed-loop controller.			
Dependency:	Setting 1 automatically disables normal ramp times set in P1120 and P1121 and the normal frequency setpoints. Following an OFF1 or OFF3 command, however, the inverter frequency will ramp down to zero using the ramp time set in P1121 (P1135 for OFF3).			
Notice:	The minimum and maximum motor frequencies (P1080 and P1082) as well as the skip frequencies (P1091 to P1094) remain active on the inverter output. However, enabling skip frequencies with PID control can produce instabilities.			

Note: The PID setpoint source is selected using P2253.
 The PID setpoint and the PID feedback signal are interpreted as [%] values (not [Hz]).
 The output of the PID controller is displayed as [%] and then normalized into [Hz] through P2000 (reference frequency) when PID is enabled.
 The reverse command is not active whilst PID is active.
 Attention: p2200 and p2803 are locked parameter against each other. PID and FFB of the same dataset cannot be active at same time.

p2201[0...2]	Fixed PID setpoint 1 / Fixed PID setp. 1		
	Access level: 2	Calculated: -	Data type: FloatingPoint32
	Can be changed: U, T	Scaling: -	Data set: DDS
	Min -200.00 [%]	Max 200.00 [%]	Factory setting 0.00 [%]

Description: Defines Fixed PID Setpoint 1.
 There are 2 types of fixed frequencies:

1. Direct selection (P2216 = 1):
 - In this mode of operation 1 Fixed Frequency selector (P2220...P2223) selects 1 fixed frequency.
 - If several inputs are active together, the selected frequencies are summed.
 E.g.: PID-FF1 + PID-FF2 + PID-FF3 + PID-FF4.
2. Binary coded selection (P2216 = 2):
 - Up to 16 different fixed frequency values can be selected using this method.
 - The fixed frequencies are selected according to FP3310.

Dependency: P2200 = 1 required in user access level 2 to enable setpoint source.

Note: You may mix different types of frequencies; however, remember that they will be summed if selected together.
 P2201 = 100 % corresponds to 4000 hex.

p2202[0...2]	Fixed PID setpoint 2 / Fixed PID setp. 2		
	Access level: 2	Calculated: -	Data type: FloatingPoint32
	Can be changed: U, T	Scaling: -	Data set: DDS
	Min -200.00 [%]	Max 200.00 [%]	Factory setting 10.00 [%]

Description: Defines Fixed PID Setpoint 2

Note: See P2201 (Fixed PID Setpoint 1).

p2203[0...2]	Fixed PID setpoint 3 / Fixed PID setp. 3		
	Access level: 2	Calculated: -	Data type: FloatingPoint32
	Can be changed: U, T	Scaling: -	Data set: DDS
	Min -200.00 [%]	Max 200.00 [%]	Factory setting 20.00 [%]

Description: Defines Fixed PID Setpoint 3

Note: See P2201 fixed PID setpoint 1 (FF-PID 1).

p2204[0...2]	Fixed PID setpoint 4 / Fixed PID setp. 4		
	Access level: 2	Calculated: -	Data type: FloatingPoint32
	Can be changed: U, T	Scaling: -	Data set: DDS
	Min -200.00 [%]	Max 200.00 [%]	Factory setting 30.00 [%]

Description: Defines Fixed PID Setpoint 4

Note: See P2201 (Fixed PID Setpoint 1).

p2205[0...2]	Fixed PID setpoint 5 / Fixed PID setp. 5		
	Access level: 2	Calculated: -	Data type: FloatingPoint32
	Can be changed: U, T	Scaling: -	Data set: DDS
	Min -200.00 [%]	Max 200.00 [%]	Factory setting 40.00 [%]
Description:	Defines Fixed PID Setpoint 5		
Note:	See P2201 (Fixed PID Setpoint 1).		
p2206[0...2]	Fixed PID setpoint 6 / Fixed PID setp. 6		
	Access level: 2	Calculated: -	Data type: FloatingPoint32
	Can be changed: U, T	Scaling: -	Data set: DDS
	Min -200.00 [%]	Max 200.00 [%]	Factory setting 50.00 [%]
Description:	Defines Fixed PID Setpoint 6		
Note:	See P2201 (Fixed PID Setpoint 1).		
p2207[0...2]	Fixed PID setpoint 7 / Fixed PID setp. 7		
	Access level: 2	Calculated: -	Data type: FloatingPoint32
	Can be changed: U, T	Scaling: -	Data set: DDS
	Min -200.00 [%]	Max 200.00 [%]	Factory setting 60.00 [%]
Description:	Defines Fixed PID Setpoint 7		
Note:	See P2201 (Fixed PID Setpoint 1).		
p2208[0...2]	Fixed PID setpoint 8 / Fixed PID setp. 8		
	Access level: 2	Calculated: -	Data type: FloatingPoint32
	Can be changed: U, T	Scaling: -	Data set: DDS
	Min -200.00 [%]	Max 200.00 [%]	Factory setting 70.00 [%]
Description:	Defines Fixed PID Setpoint 8		
Note:	See P2201 (Fixed PID Setpoint 1).		
p2209[0...2]	Fixed PID setpoint 9 / Fixed PID setp. 9		
	Access level: 2	Calculated: -	Data type: FloatingPoint32
	Can be changed: U, T	Scaling: -	Data set: DDS
	Min -200.00 [%]	Max 200.00 [%]	Factory setting 80.00 [%]
Description:	Defines Fixed PID Setpoint 9		
Note:	See P2201 (Fixed PID Setpoint 1).		
p2210[0...2]	Fixed PID setpoint 10 / Fixed PID setp. 10		
	Access level: 2	Calculated: -	Data type: FloatingPoint32
	Can be changed: U, T	Scaling: -	Data set: DDS
	Min -200.00 [%]	Max 200.00 [%]	Factory setting 90.00 [%]
Description:	Defines Fixed PID Setpoint 10		
Note:	See P2201 (Fixed PID Setpoint 1).		

p2211[0...2]	Fixed PID setpoint 11 / Fixed PID setp. 11		
	Access level: 2	Calculated: -	Data type: FloatingPoint32
	Can be changed: U, T	Scaling: -	Data set: DDS
	Min -200.00 [%]	Max 200.00 [%]	Factory setting 100.00 [%]
Description:	Defines Fixed PID Setpoint 11		
Note:	See P2201 (Fixed PID Setpoint 1).		
p2212[0...2]	Fixed PID setpoint 12 / Fixed PID setp. 12		
	Access level: 2	Calculated: -	Data type: FloatingPoint32
	Can be changed: U, T	Scaling: -	Data set: DDS
	Min -200.00 [%]	Max 200.00 [%]	Factory setting 110.00 [%]
Description:	Defines Fixed PID Setpoint 12		
Note:	See P2201 (Fixed PID Setpoint 1).		
p2213[0...2]	Fixed PID setpoint 13 / Fixed PID setp. 13		
	Access level: 2	Calculated: -	Data type: FloatingPoint32
	Can be changed: U, T	Scaling: -	Data set: DDS
	Min -200.00 [%]	Max 200.00 [%]	Factory setting 120.00 [%]
Description:	Defines Fixed PID Setpoint 13		
Note:	See P2201 (Fixed PID Setpoint 1).		
p2214[0...2]	Fixed PID setpoint 14 / Fixed PID setp. 14		
	Access level: 2	Calculated: -	Data type: FloatingPoint32
	Can be changed: U, T	Scaling: -	Data set: DDS
	Min -200.00 [%]	Max 200.00 [%]	Factory setting 130.00 [%]
Description:	Defines Fixed PID Setpoint 14		
Note:	See P2201 (Fixed PID Setpoint 1).		
p2215[0...2]	Fixed PID setpoint 15 / Fixed PID setp. 15		
	Access level: 2	Calculated: -	Data type: FloatingPoint32
	Can be changed: U, T	Scaling: -	Data set: DDS
	Min -200.00 [%]	Max 200.00 [%]	Factory setting 130.00 [%]
Description:	Defines Fixed PID Setpoint 15		
Note:	See P2201 (Fixed PID Setpoint 1).		
p2216[0...2]	Fixed PID setpoint mode / Fix.PID Mode		
	Access level: 2	Calculated: -	Data type: Unsigned16
	Can be changed: T	Scaling: -	Data set: DDS
	Min 1	Max 2	Factory setting 2
Description:	Fixed frequencies for PID setpoint can be selected in two different modes. Parameter P2216 defines the mode.		
Value:	1: Direct selection 2: Binary selection		

p2220[0...2]	BI: Fixed PID setp. select Bit 0 / PID setp->Bit 0				
	Access level: 3	Calculated: -	Data type: U32 / Binary		
	Can be changed: T	Scaling: -	Data set: CDS		
	Min	Max	Factory setting		
	-	-	2091.0		
Description:	Defines command source of fixed PID setpoint selection Bit 0.				
p2221[0...2]	BI: Fixed PID setp. select Bit 1 / PID setp->Bit 1				
	Access level: 3	Calculated: -	Data type: U32 / Binary		
	Can be changed: T	Scaling: -	Data set: CDS		
	Min	Max	Factory setting		
	-	-	2091.1		
Description:	Defines command source of fixed PID setpoint selection Bit 1.				
p2222[0...2]	BI: Fixed PID setp. select Bit 2 / PID setp->Bit 2				
	Access level: 3	Calculated: -	Data type: U32 / Binary		
	Can be changed: T	Scaling: -	Data set: CDS		
	Min	Max	Factory setting		
	-	-	2091.2		
Description:	Defines command source of fixed PID setpoint selection Bit 2.				
p2223[0...2]	BI: Fixed PID setp. select Bit 3 / PID setp->Bit 3				
	Access level: 3	Calculated: -	Data type: U32 / Binary		
	Can be changed: T	Scaling: -	Data set: CDS		
	Min	Max	Factory setting		
	-	-	2091.3		
Description:	Defines command source of fixed PID setpoint selection Bit 3.				
r2224	CO: Act. fixed PID setpoint / Fixed.PID setp				
	Access level: 2	Calculated: -	Data type: FloatingPoint32		
	Unit: [%]	Scaling: -	Data set: -		
Description:	Displays total output of PID fixed setpoint selection.				
Note:	r2224 = 100 % corresponds to 4000 hex				
r2225.0	BO: PID Fixed frequency status / PID FF Status				
	Access level: 3	Calculated: -	Data type: Unsigned16		
	Unit: -	Scaling: -	Data set: -		
Description:	Displays the status of PID fixed frequencies.				
Bit field:	Bit	Signal name	1 signal	0 signal	FP
	00	Status of FF	Yes	No	-
p2231[0...2]	PID-MOP mode / PID-MOP mode.				
	Access level: 2	Calculated: -	Data type: Unsigned16		
	Can be changed: U, T	Scaling: -	Data set: DDS		
	Min	Max	Factory setting		
	-	-	0		
Description:	PID-MOP mode specification				
Bit field:	Bit	Signal name	1 signal	0 signal	FP
	00	Setpoint store activ	Yes	No	-
	01	No On-state for MOP necessary	Yes	No	-

Note: Defines the operation mode of the motorized potentiometer.
See P2240 (setpoint of PID-MOP).

p2232	Inhibit rev. direct. of PID-MOP / Inhib. PID-MOD rev		
	Access level: 2	Calculated: -	Data type: Unsigned16
	Can be changed: T	Scaling: -	Data set: -
	Min 0	Max 1	Factory setting 1
Description:	Inhibits reverse setpoint selection of the PID-MOP.		
Value:	0: Reverse direction is allowed 1: Reverse direction inhibited		
Note:	Setting 0 enables a change of motor direction using the motor potentiometer setpoint (increase/decrease frequency).		
p2235[0...2]	BI: Enable PID-MOP (UP-cmd) / PID-MOP (UP)		
	Access level: 3	Calculated: -	Data type: U32 / Binary
	Can be changed: T	Scaling: -	Data set: CDS
	Min -	Max -	Factory setting 0
Description:	Defines source of UP command.		
Dependency:	To change setpoint: - Configure a digital input as source		
Notice:	If this command is enabled by short pulses of less than 1 second, the frequency is changed in steps of 0.2 % (P0310). When the signal is enabled longer than 1 second the ramp generator accelerates with the rate of P2247.		
p2236[0...2]	BI: Enable PID-MOP (DOWN-cmd) / PID-MOP (DWN)		
	Access level: 3	Calculated: -	Data type: U32 / Binary
	Can be changed: T	Scaling: -	Data set: CDS
	Min -	Max -	Factory setting 0
Description:	Defines source of DOWN command.		
Dependency:	To change setpoint: - Configure a digital input as source		
Notice:	If this command is enabled by short pulses of less than 1 second, the frequency is changed in steps of 0.2 % (P0310). When the signal is enabled longer than 1 second the ramp generator decelerates with the rate of P2248.		
p2240[0...2]	Setpoint of PID-MOP / Setp. of PID-MOP		
	Access level: 2	Calculated: -	Data type: FloatingPoint32
	Can be changed: U, T	Scaling: -	Data set: DDS
	Min -200.00 [%]	Max 200.00 [%]	Factory setting 10.00 [%]
Description:	Setpoint of the motor potentiometer. Allows user to set a digital PID setpoint in [%].		
Note:	P2240 = 100 % corresponds to 4000 hex The start value gets active (for the MOP output) only at the start of the MOP. The parameter P2231 influences the start value behaviour as follows: <ul style="list-style-type: none"> • P2231=0: P2240 gets immediately active in the OFF-state and when changed in the ON-state, it gets active after the next OFF and ON cycle. • P2231=1: The last MOP output before stop is stored as starting value, since storing is selected, so a change of P2240 while in ON-state has no effect. In OFF-state P2240 can be changed. 		

- P2231=2:
The MOP is active every time, so the change of P2240 affects after the next power cycle or a change of P2231 to 0.
- P2231=3:
The last MOP output before power down is stored as starting value, since the MOP is active independent from the ON-command, a change of P2240 has only effect in the case of a change of P2231.

p2241[0...2]	BI: PID-MOP select setpoint auto/manu / Setp. auto/manu		
	Access level: 3	Calculated: -	Data type: U32 / Binary
	Can be changed: T	Scaling: -	Data set: CDS
	Min	Max	Factory setting
	-	-	0
Description:	Sets the signal source to change over from manual to automatic mode. If using the motorized potentiometer in the manual mode the setpoint is changed using two signals for up and down, e.g. P2235 and P2236. If using the automatic mode the setpoint must be interconnected via the connector input (P2242). 0 : manually 1 : automatically		
Notice:	Refer to: P2235, P1036, P2242		
p2242[0...2]	CI: PID-MOP auto setpoint / PMOP auto setpoint		
	Access level: 3	Calculated: -	Data type: U32 / Integer32
	Can be changed: T	Scaling: -	Data set: CDS
	Min	Max	Factory setting
	-	-	0
Description:	Sets the signal source for the setpoint of the motorized potentiometer if automatic mode P2241 is selected.		
Notice:	Refer to: P2241		
p2243[0...2]	BI: PID-MOP accept rampgenerator setpoint / PMOP acc RFG setpo		
	Access level: 3	Calculated: -	Data type: U32 / Binary
	Can be changed: T	Scaling: -	Data set: CDS
	Min	Max	Factory setting
	-	-	0
Description:	Sets the signal source for the setting command to accept the setting value for the motorized potentiometer. The value becomes effective for a 0/1 edge of the setting command.		
Notice:	Refer to: P2244		
p2244[0...2]	CI: PID-MOP rampgenerator setpoint / PMOP RFG setpoint		
	Access level: 3	Calculated: -	Data type: U32 / Integer32
	Can be changed: T	Scaling: -	Data set: CDS
	Min	Max	Factory setting
	-	-	0
Description:	Sets the signal source for the setpoint value for the MOP. The value becomes effective for a 0/1 edge of the setting command.		
Notice:	Refer to: P2243		
r2245	CO: PID-MOP input frequency of the RFG / PMOP RFG input		
	Access level: 3	Calculated: -	Data type: FloatingPoint32
	Unit: [%]	Scaling: -	Data set: -
Description:	Displays the motorized potentiometer setpoint before it passed the PID-MOP RFG.		

p2247[0...2]	PID-MOP ramp-up time of the RFG / PMOP ramp-up time		
	Access level: 2	Calculated: -	Data type: FloatingPoint32
	Can be changed: U, T	Scaling: -	Data set: DDS
	Min 0.00 [s]	Max 1000.00 [s]	Factory setting 10.00 [s]
Description:	Sets the ramp-up time for the internal PID-MOP ramp-function generator. The setpoint is changed from zero up to limit defined in P1082 within this time.		
Notice:	Refer to: P2248, P1082		
p2248[0...2]	PID-MOP ramp-down time of the RFG / PMOP rampdown time		
	Access level: 2	Calculated: -	Data type: FloatingPoint32
	Can be changed: U, T	Scaling: -	Data set: DDS
	Min 0.00 [s]	Max 1000.00 [s]	Factory setting 10.00 [s]
Description:	Sets the ramp-down time for the internal PID-MOP ramp-function generator. The setpoint is changed from limit defined in P1082 down to zero within this time.		
Notice:	Refer to: P2247, P1082		
r2250	CO: Output setpoint of PID-MOP / PMOP outp. setp		
	Access level: 2	Calculated: -	Data type: FloatingPoint32
	Unit: [%]	Scaling: PERCENT	Data set: -
Description:	Displays output setpoint of motor potentiometer in [%].		
p2251	PID mode / PID mode		
	Access level: 3	Calculated: -	Data type: Unsigned16
	Can be changed: T	Scaling: -	Data set: -
	Min 0	Max 1	Factory setting 0
Description:	Enables function of PID controller.		
Value:	0: PID as setpoint 1: PID as trim		
Dependency:	Active when PID loop is enabled (see P2200).		
p2253[0...2]	CI: PID setpoint / PID setpoint		
	Access level: 2	Calculated: -	Data type: U32 / Integer16
	Can be changed: U, T	Scaling: 4000H	Data set: CDS
	Min -	Max -	Factory setting 0
Description:	Defines setpoint source for PID setpoint input. This parameter allows the user to select the source of the PID setpoint. Normally, a digital setpoint is selected either using a fixed PID setpoint or an active setpoint.		
p2254[0...2]	CI: PID trim source / PID trim source		
	Access level: 3	Calculated: -	Data type: U32 / Integer16
	Can be changed: U, T	Scaling: 4000H	Data set: CDS
	Min -	Max -	Factory setting 0
Description:	Selects trim source for PID setpoint. This signal is multiplied by the trim gain and added to the PID setpoint.		

p2255	PID setpoint gain factor / PID setp.gain fact		
	Access level: 3	Calculated: -	Data type: FloatingPoint32
	Can be changed: U, T	Scaling: -	Data set: -
	Min 0.00	Max 100.00	Factory setting 100.00
Description:	Gain factor for PID setpoint. The PID setpoint input is multiplied by this gain factor to produce a suitable ratio between setpoint and trim.		
p2256	PID trim gain factor / PID trim gain fact		
	Access level: 3	Calculated: -	Data type: FloatingPoint32
	Can be changed: U, T	Scaling: -	Data set: -
	Min 0.00	Max 100.00	Factory setting 100.00
Description:	Gain factor for PID trim. This gain factor scales the trim signal, which is added to the main PID setpoint.		
p2257	Ramp-up time for PID setpoint / PID setp. ramp-up		
	Access level: 2	Calculated: -	Data type: FloatingPoint32
	Can be changed: U, T	Scaling: -	Data set: -
	Min 0.00 [s]	Max 650.00 [s]	Factory setting 1.00 [s]
Description:	Sets the ramp-up time for the PID setpoint.		
Dependency:	P2200 = 1 (PID control is enabled) disable normal ramp-up time (P1120). PID ramp time effective only on PID setpoint and only active when PID setpoint is changed or when RUN command is given (when PID setpoint uses this ramp to reach its value from 0 %).		
Notice:	Setting the ramp-up time too short may cause the inverter to trip, on overcurrent for example.		
p2258	Ramp-down time for PID setpoint / PID setp. ramp-dwn		
	Access level: 2	Calculated: -	Data type: FloatingPoint32
	Can be changed: U, T	Scaling: -	Data set: -
	Min 0.00 [s]	Max 650.00 [s]	Factory setting 1.00 [s]
Description:	Sets ramp-down time for PID setpoint.		
Dependency:	P2200 = 1 (PID control is enabled) disables normal ramp-down time (P1121). PID setpoint ramp effective only on PID setpoint changes. P1121 (ramp-down time) and P1135 (OFF3 ramp-down time) define the ramp times used after OFF1 and OFF3 respectively.		
Notice:	Setting the ramp-down time too short can cause the inverter to trip on overvoltage F0002 / overcurrent F0001.		
r2260	CO: PID setpoint after PID-RFG / PID setp <-RFG		
	Access level: 2	Calculated: -	Data type: FloatingPoint32
	Unit: [%]	Scaling: -	Data set: -
Description:	Displays total active PID setpoint after PID-RFG in [%].		
Note:	r2260 = 100 % corresponds to 4000 hex.		
p2261	PID setpoint filter timeconstant / PID setp.filt.Tcon		
	Access level: 3	Calculated: -	Data type: FloatingPoint32
	Can be changed: U, T	Scaling: -	Data set: -
	Min 0.00 [s]	Max 60.00 [s]	Factory setting 0.00 [s]
Description:	Sets a time constant for smoothing the PID setpoint.		
Note:	p2261 = 0 = no smoothing.		

r2262	CO: Filtered PID setp. after RFG / Filt. PID setp		
	Access level: 3	Calculated: -	Data type: FloatingPoint32
	Unit: [%]	Scaling: -	Data set: -
Description:	Displays filtered PID setpoint after PID-RFG in [%].		
	r2262 is the result of the value in r2260, filtered with PT1-Filter and the time constant given in p2261.		
Note:	r2262 = 100 % corresponds to 4000 hex.		
p2263	PID controller type / PID ctrl. type		
	Access level: 3	Calculated: -	Data type: Unsigned16
	Can be changed: T	Scaling: -	Data set: -
	Min	Max	Factory setting
	0	1	1
Description:	Sets the PID controller type.		
Value:	0: D component on feedback signal 1: D component on error signal		
p2264[0...2]	CI: PID feedback / PID feedback		
	Access level: 2	Calculated: -	Data type: U32 / Integer16
	Can be changed: U, T	Scaling: 4000H	Data set: CDS
	Min	Max	Factory setting
	-	-	0
Description:	Selects the source of the PID feedback signal.		
Note:	When analog input is selected, offset and gain can be implemented using parameters P0756 to P0760 (AI scaling).		
p2265	PID feedback filter timeconstant / Fdbck.filt. Tconst		
	Access level: 2	Calculated: -	Data type: FloatingPoint32
	Can be changed: U, T	Scaling: -	Data set: -
	Min	Max	Factory setting
	0.00 [s]	60.00 [s]	0.00 [s]
Description:	Defines time constant for PID feedback filter.		
r2266	CO: PID filtered feedback / PID filt.fdbck		
	Access level: 2	Calculated: -	Data type: FloatingPoint32
	Unit: [%]	Scaling: -	Data set: -
Description:	Displays PID feedback signal in [%].		
Note:	r2266 = 100 % corresponds to 4000 hex.		
p2267	Max. value for PID feedback / PID fdbck max. val		
	Access level: 3	Calculated: -	Data type: FloatingPoint32
	Can be changed: U, T	Scaling: -	Data set: -
	Min	Max	Factory setting
	-200.00 [%]	200.00 [%]	100.00 [%]
Description:	Sets the upper limit for the value of the feedback signal in [%].		
Notice:	When PID is enabled (P2200 = 1) and the signal rises above this value, the inverter will trip with F0222 .		
Note:	p2267 = 100 % corresponds to 4000 hex.		

p2268	Min. value for PID feedback / PID fdbck min. val		
	Access level: 3	Calculated: -	Data type: FloatingPoint32
	Can be changed: U, T	Scaling: -	Data set: -
	Min -200.00 [%]	Max 200.00 [%]	Factory setting 0.00 [%]
Description:	Sets lower limit for value of feedback signal in [%].		
Notice:	When PID is enabled (P2200 = 1) and the signal drops below this value, the inverter will trip with F0221.		
Note:	P2268 = 100 % corresponds to 4000 hex.		
p2269	Gain applied to PID feedback / PID feedback gain		
	Access level: 3	Calculated: -	Data type: FloatingPoint32
	Can be changed: U, T	Scaling: -	Data set: -
	Min 0.00	Max 500.00	Factory setting 100.00
Description:	Allows the user to scale the PID feedback as a percentage value [%]. A gain of 100.0 % means that feedback signal has not changed from its default value.		
p2270	PID feedback function selector / PID fdbck fnct sel		
	Access level: 3	Calculated: -	Data type: Unsigned16
	Can be changed: U, T	Scaling: -	Data set: -
	Min 0	Max 3	Factory setting 0
Description:	Applies mathematical functions to the PID feedback signal, allowing multiplication of the result by P2269 (gain applied to PID feedback).		
Value:	0: Disabled 1: Square root (root(x)) 2: Square (x*x) 3: Cube (x*x*x)		
p2271	PID transducer type / PID trans. type		
	Access level: 2	Calculated: -	Data type: Unsigned16
	Can be changed: U, T	Scaling: -	Data set: -
	Min 0	Max 1	Factory setting 0
Description:	Allows the user to select the transducer type for the PID feedback signal.		
Value:	0: Disabled 1: Inversion of PID feedback signal		
Notice:	It is essential that you select the correct transducer type. If you are unsure whether 0 or 1 is applicable, you can determine the correct type as follows: 1. Disable the PID function (P2200 = 0). 2. Increase the motor frequency while measuring the feedback signal. 3. If the feedback signal increases with an increase in motor frequency, the PID transducer type should be 0. 4. If the feedback signal decreases with an increase in motor frequency the PID transducer type should be set to 1.		
r2272	CO: PID scaled feedback / PID scal fdbck		
	Access level: 2	Calculated: -	Data type: FloatingPoint32
	Unit: [%]	Scaling: -	Data set: -
Description:	Displays PID scaled feedback signal in [%].		
Note:	r2272 = 100 % corresponds to 4000 hex.		

r2273	CO: PID error / PID error		
	Access level: 2	Calculated: -	Data type: FloatingPoint32
	Unit: [%]	Scaling: -	Data set: -
Description:	Displays PID error (difference) signal between setpoint and feedback signals in [%].		
Note:	r2273 = 100 % corresponds to 4000 hex.		
p2274	PID derivative time / PID deriv. time		
	Access level: 2	Calculated: -	Data type: FloatingPoint32
	Can be changed: U, T	Scaling: -	Data set: -
	Min 0.000 [s]	Max 60.000 [s]	Factory setting 0.000 [s]
Description:	Sets PID derivative time. P2274 = 0: The derivative term does not have any effect (it applies a gain of 1).		
p2280	PID proportional gain / PID prop. gain		
	Access level: 2	Calculated: -	Data type: FloatingPoint32
	Can be changed: U, T	Scaling: -	Data set: -
	Min 0.000	Max 65.000	Factory setting 3.000
Description:	Allows user to set proportional gain for PID controller. The PID controller is implemented using the standard model. For best results, enable both P and I terms.		
Dependency:	P2280 = 0 (P term of PID = 0): The I term acts on the square of the error signal. P2285 = 0 (I term of PID = 0): PID controller acts as a P or PD controller respectively.		
Note:	If the system is prone to sudden step changes in the feedback signal, P term should normally be set to a small value (0.5) with a faster I term for optimum performance.		
p2285	PID integral time / PID integral time		
	Access level: 2	Calculated: -	Data type: FloatingPoint32
	Can be changed: U, T	Scaling: -	Data set: -
	Min 0.000 [s]	Max 60.000 [s]	Factory setting 0.000 [s]
Description:	Sets integral time constant for PID controller.		
Note:	See P2280 (PID proportional gain).		
p2291	PID output upper limit / PID outp.upper lim		
	Access level: 2	Calculated: -	Data type: FloatingPoint32
	Can be changed: U, T	Scaling: -	Data set: -
	Min -200.00 [%]	Max 200.00 [%]	Factory setting 100.00 [%]
Description:	Sets upper limit for PID controller output in [%].		
Dependency:	If f_max (P1082) is greater than P2000 (reference frequency), either P2000 or P2291 (PID output upper limit) must be changed to achieve f_max.		
Note:	P2291 = 100 % corresponds to 4000 hex (as defined by P2000 (reference frequency)).		

p2292	PID output lower limit / PID outp.lower lim		
	Access level: 2	Calculated: -	Data type: FloatingPoint32
	Can be changed: U, T	Scaling: -	Data set: -
	Min -200.00 [%]	Max 200.00 [%]	Factory setting 0.00 [%]
Description:	Sets lower limit for the PID controller output in [%].		
Dependency:	A negative value allows bipolar operation of PID controller.		
Note:	P2292 = 100 % corresponds to 4000 hex.		
p2293	Ramp-up /-down time of PID limit / PID lim. ramp time		
	Access level: 3	Calculated: -	Data type: FloatingPoint32
	Can be changed: U, T	Scaling: -	Data set: -
	Min 0.00 [s]	Max 100.00 [s]	Factory setting 1.00 [s]
Description:	Sets maximum ramp rate on output of PID. When PI is enabled, the output limits are ramped up from 0 to the limits set in P2291 (PID output upper limit) and P2292 (PID output lower limit). Limits prevent large step changes appearing on the output of the PID when the inverter is started. Once the limits have been reached, the PID controller output is instantaneous. These ramp times are used whenever a RUN command is issued.		
Note:	If an OFF1 or OFF 3 are issued, the inverter output frequency ramps down as set in P1121 (ramp-down time) or P1135 (OFF3 ramp-down time).		
r2294	CO: Act. PID output / Act.PID output		
	Access level: 2	Calculated: -	Data type: FloatingPoint32
	Unit: [%]	Scaling: -	Data set: -
Description:	Displays PID output in [%].		
Note:	r2294 = 100 % corresponds to 4000 hex.		
p2295	Gain applied to PID output / PID output scale		
	Access level: 3	Calculated: -	Data type: FloatingPoint32
	Can be changed: U, T	Scaling: -	Data set: -
	Min -100.00	Max 100.00	Factory setting 100.00
Description:	Allows the user to scale the PID output as a percentage value [%]. A gain of 100.0 % means that output signal has not changed from its default value.		
p2350	PID autotune enable / PID autotune		
	Access level: 2	Calculated: -	Data type: Unsigned16
	Can be changed: U, T	Scaling: -	Data set: -
	Min 0	Max 4	Factory setting 0
Description:	Enables autotune function of PID controller.		
Value:	0: PID autotuning disabled 1: PID autotuning via Ziegler Nichols (ZN) standard 2: PID autotuning as 1 plus some overshoot (O/S) 3: PID autotuning as 2 little or no overshoot (O/S) 4: PID autotuning PI only, quarter damped response		
Dependency:	Active when PID loop is enabled (see P2200).		

- Note:**
- P2350 = 1
This is the standard Ziegler Nichols (ZN) tuning which should be a quarter damped response to a step.
 - P2350 = 2
This tuning will give some overshoot (O/S) but should be faster than option 1.
 - P2350 = 3
This tuning should give little or no overshoot but will not be as fast as option 2.
 - P2350 = 4
This tuning only changes values of P and I and should be a quarter damped response.

The option to be selected depends on the application but broadly speaking option 1 will give a good response, whereas if a faster response is desired option 2 should be selected.

If no overshoot is desired then option 3 is the choice. For cases where no D term is wanted then option 4 can be selected.

The tuning procedure is the same for all options. It is just the calculation of P and D values that is different.

After autotune this parameter is set to zero (autotune completed).

p2354	PID tuning timeout length / PID tuning t/o.		
	Access level: 3	Calculated: -	Data type: Unsigned16
	Can be changed: U, T	Scaling: -	Data set: -
	Min 60 [s]	Max 65000 [s]	Factory setting 240 [s]
Description:	This parameter determines the time that the autotuning code will wait before aborting a tuning run if no oscillation has been obtained.		
p2355	PID tuning offset / PID tuning offset		
	Access level: 3	Calculated: -	Data type: FloatingPoint32
	Can be changed: U, T	Scaling: -	Data set: -
	Min 0.00 [%]	Max 20.00 [%]	Factory setting 5.00 [%]
Description:	Sets applied offset and deviation for PID autotuning.		
Note:	This can be varied depending on plant conditions e.g. a very long system time constant might require a larger value.		
p2800	Enable FFBS / Enable FFBS		
	Access level: 3	Calculated: -	Data type: Unsigned16
	Can be changed: U, T	Scaling: -	Data set: -
	Min 0	Max 1	Factory setting 0
Description:	Free function blocks (FFB) are enabled in two steps: 1. Parameter P2800 enables all free function blocks (P2800 = 1). 2. Parameters P2801 and P2802 respectively, enable each free function block individually. Additionally fast free function blocks can be enabled via P2803 = 1.		
Value:	0: Disable 1: Enable		
Dependency:	All active function blocks will be calculated in every 128 ms, fast free function blocks in every 8 ms.		

p2802[0...13]	Activate FFBS / Activate FFBS		
	Access level: 3	Calculated: -	Data type: Unsigned16
	Can be changed: U, T	Scaling: -	Data set: -
	Min 0	Max 3	Factory setting 0
Description:	Enables free function blocks (FFB) and determines the chronological order of each function block. See parameter P2801.		
Value:	0: Not Active 1: Level 1 2: Level 2 3: Level 3		
Index:	[0] = Enable timer 1 [1] = Enable timer 2 [2] = Enable timer 3 [3] = Enable timer 4 [4] = Enable ADD 1 [5] = Enable ADD 2 [6] = Enable SUB 1 [7] = Enable SUB 2 [8] = Enable MUL 1 [9] = Enable MUL 2 [10] = Enable DIV 1 [11] = Enable DIV 2 [12] = Enable CMP 1 [13] = Enable CMP 2		
Dependency:	Set P2800 to 1 to enable function blocks. All active function blocks, enabled with P2802, will be calculated in every 128 ms.		

p2803[0...2]	Enable FastFFBs / Enable FastFFBs		
	Access level: 3	Calculated: -	Data type: Unsigned16
	Can be changed: U, T	Scaling: -	Data set: CDS
	Min 0	Max 1	Factory setting 0
Description:	Fast free function blocks (FFB) are enabled in two steps: 1. Parameter P2803 enables the use of fast free function blocks (P2803 = 1). 2. Parameter P2801 enables each fast free function block individually and determines the chronological order (P2801[x] = 4 ... 6).		
Value:	0: Disable 1: Enable		
Dependency:	All active fast function blocks will be calculated in every 8 ms.		
Note:	Attention: P2200 and P2803 are locked parameter against each other. PID and FFB of the same dataset cannot be active at same time.		

p2810[0...1]	BI: AND 1 / AND 1		
	Access level: 3	Calculated: -	Data type: U32 / Binary
	Can be changed: U, T	Scaling: -	Data set: -
	Min	Max	Factory setting
	-	-	0
Description:	P2810[0], P2810[1] define inputs of AND 1 element, output is P2811.		

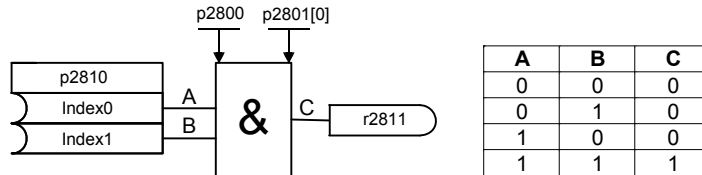

Index:	[0] = Binector input 0 (BI 0) [1] = Binector input 1 (BI 1)
Dependency:	P2801[0] assigns the AND element to the processing sequence.

r2811.0	BO: AND 1 / AND 1		
	Access level: 3	Calculated: -	Data type: Unsigned16
	Unit: -	Scaling: -	Data set: -
Description:	Output of AND 1 element. Displays and logic of bits defined in P2810[0], P2810[1].		
Bit field:	Bit	Signal name	1 signal
	00	Output of BO	Yes
			0 signal
			No
			FP
			-
Dependency:	P2801[0] assigns the AND element to the processing sequence.		

p2812[0...1]	BI: AND 2 / AND 2		
	Access level: 3	Calculated: -	Data type: U32 / Binary
	Can be changed: U, T	Scaling: -	Data set: -
	Min	Max	Factory setting
	-	-	0
Description:	P2812[0], 2812[1] define inputs of AND 2 element, output is P2813.		
Index:	[0] = Binector input 0 (BI 0) [1] = Binector input 1 (BI 1)		
Dependency:	P2801[1] assigns the AND element to the processing sequence.		

r2813.0	BO: AND 2 / AND 2		
	Access level: 3	Calculated: -	Data type: Unsigned16
	Unit: -	Scaling: -	Data set: -
Description:	Output of AND 2 element. Displays and logic of bits defined in P2812[0], P2812[1].		
Bit field:	Bit	Signal name	1 signal
	00	Output of BO	Yes
			0 signal
			No
			FP
			-
Dependency:	P2801[1] assigns the AND element to the processing sequence.		

p2814[0...1] **BI: AND 3 / AND 3**

Access level: 3 **Calculated:** - **Data type:** U32 / Binary
Can be changed: U, T **Scaling:** - **Data set:** -

Min **Max**
- -

Factory setting
0

Description: P2814[0], P2814[1] define inputs of AND 3 element, output is P2815.
Index: [0] = Binector input 0 (BI 0)
[1] = Binector input 1 (BI 1)
Dependency: P2801[2] assigns the AND element to the processing sequence.

r2815.0 **BO: AND 3 / AND 3**

Access level: 3 **Calculated:** - **Data type:** Unsigned16
Unit: - **Scaling:** - **Data set:** -

Description: Output of AND 3 element.
Displays and logic of bits defined in P2814[0], P2814[1].

Bit field:

Bit	Signal name	1 signal	0 signal	FP
00	Output of BO	Yes	No	-

Dependency: P2801[2] assigns the AND element to the processing sequence.

p2816[0...1] **BI: OR 1 / OR 1**

Access level: 3 **Calculated:** - **Data type:** U32 / Binary
Can be changed: U, T **Scaling:** - **Data set:** -

Min **Max**
- -

Factory setting
0

Description: P2816[0], P2816[1] define inputs of OR 1 element, output is P2817.

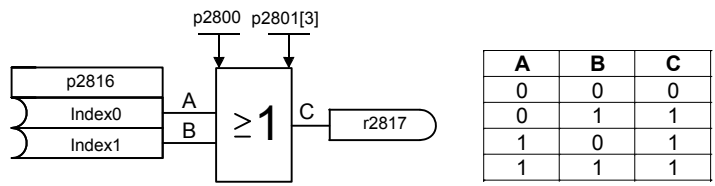

Index: [0] = Binector input 0 (BI 0)
[1] = Binector input 1 (BI 1)
Dependency: P2801[3] assigns the OR element to the processing sequence.

r2817.0 **BO: OR 1 / OR 1**

Access level: 3 **Calculated:** - **Data type:** Unsigned16
Unit: - **Scaling:** - **Data set:** -

Description: Output of OR 1 element.
Displays or logic of bits defined in P2816[0], P2816[1].

Bit field:

Bit	Signal name	1 signal	0 signal	FP
00	Output of BO	Yes	No	-

Dependency: P2801[3] assigns the OR element to the processing sequence.

p2818[0...1] **BI: OR 2 / OR 2**

Access level: 3 **Calculated:** - **Data type:** U32 / Binary
Can be changed: U, T **Scaling:** - **Data set:** -

Min **Max**
 - - **Factory setting**
 - - 0

Description: P2818[0], P2818[1] define inputs of OR 2 element, output is P2819.
Index: [0] = Binector input 0 (BI 0)
 [1] = Binector input 1 (BI 1)
Dependency: P2801[4] assigns the OR element to the processing sequence.

r2819.0 **BO: OR 2 / OR 2**

Access level: 3 **Calculated:** - **Data type:** Unsigned16
Unit: - **Scaling:** - **Data set:** -

Description: Output of OR 2 element.
 Displays or logic of bits defined in P2818[0], P2818[1].

Bit field:

Bit	Signal name	1 signal	0 signal	FP
00	Output of BO	Yes	No	-

Dependency: P2801[4] assigns the OR element to the processing sequence.

p2820[0...1] **BI: OR 3 / OR 3**

Access level: 3 **Calculated:** - **Data type:** U32 / Binary
Can be changed: U, T **Scaling:** - **Data set:** -

Min **Max**
 - - **Factory setting**
 - - 0

Description: P2820[0], P2820[1] define inputs of OR 3 element, output is P2821.
Index: [0] = Binector input 0 (BI 0)
 [1] = Binector input 1 (BI 1)
Dependency: P2801[5] assigns the OR element to the processing sequence.

r2821.0 **BO: OR 3 / OR 3**

Access level: 3 **Calculated:** - **Data type:** Unsigned16
Unit: - **Scaling:** - **Data set:** -

Description: Output of OR 3 element.
 Displays or logic of bits defined in P2820[0], P2820[1].

Bit field:

Bit	Signal name	1 signal	0 signal	FP
00	Output of BO	Yes	No	-

Dependency: P2801[5] assigns the OR element to the processing sequence.

p2822[0...1] **BI: XOR 1 / XOR 1**

Access level: 3 **Calculated:** - **Data type:** U32 / Binary
Can be changed: U, T **Scaling:** - **Data set:** -

Min **Max**
 - - **Factory setting**
 - - 0

Description: P2822[0], P2822[1] define inputs of XOR 1 element, output is P2823.

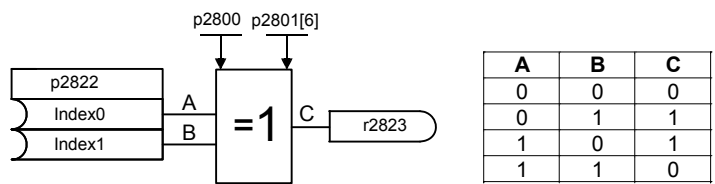

p2828	BI: NOT 1 / NOT 1	Access level: 3	Calculated: -	Data type: U32 / Binary
		Can be changed: U, T	Scaling: -	Data set: -
		Min	Max	Factory setting
		-	-	0
Description:	P2828 defines input of NOT 1 element, output is P2829.			

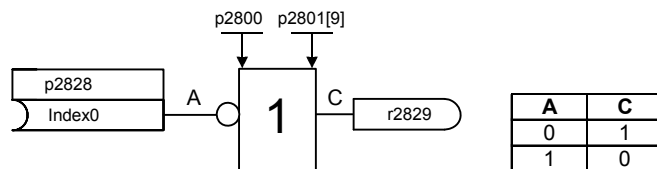

Dependency: P2801[9] assigns the NOT element to the processing sequence.

r2829.0	BO: NOT 1 / NOT 1	Access level: 3	Calculated: -	Data type: Unsigned16
		Unit: -	Scaling: -	Data set: -
Description:	Output of NOT 1 element. Displays not logic of bit defined in P2828.			
Bit field:	Bit	Signal name	1 signal	0 signal
	00	Output of BO	Yes	No
Dependency:	P2801[9] assigns the NOT element to the processing sequence.			

p2830	BI: NOT 2 / NOT 2	Access level: 3	Calculated: -	Data type: U32 / Binary
		Can be changed: U, T	Scaling: -	Data set: -
		Min	Max	Factory setting
		-	-	0
Description:	P2830 defines input of NOT 2 element, output is P2831.			
Dependency:	P2801[10] assigns the NOT element to the processing sequence.			

r2831.0	BO: NOT 2 / NOT 2	Access level: 3	Calculated: -	Data type: Unsigned16
		Unit: -	Scaling: -	Data set: -
Description:	Output of NOT 2 element. Displays not logic of bit defined in P2830.			
Bit field:	Bit	Signal name	1 signal	0 signal
	00	Output of BO	Yes	No
Dependency:	P2801[10] assigns the NOT element to the processing sequence.			

p2832	BI: NOT 3 / NOT 3	Access level: 3	Calculated: -	Data type: U32 / Binary
		Can be changed: U, T	Scaling: -	Data set: -
		Min	Max	Factory setting
		-	-	0
Description:	P2832 defines input of NOT 3 element, output is P2833.			
Dependency:	P2801[11] assigns the NOT element to the processing sequence.			

r2836.0	BO: NOT-Q D-FF 1 / NOT-Q D-FF 1			
	Access level: 3	Calculated: -	Data type: Unsigned16	
	Unit: -	Scaling: -	Data set: -	
Description:	Displays Not-output of D-FlipFlop 1, inputs are defined in P2834[0], P2834[1], P2834[2], P2834[3]			
Bit field:	Bit	Signal name	1 signal	0 signal
	00	Output of BO	Yes	No
Dependency:	P2801[12] assigns the D-FlipFlop to the processing sequence.			

p2837[0...3]	BI: D-FF 2 / D-FF 2			
	Access level: 3	Calculated: -	Data type: U32 / Binary	
	Can be changed: U, T	Scaling: -	Data set: -	
	Min	Max	Factory setting	
	-	-	0	
Description:	P2837[0], P2837[1], P2837[2], P2837[3] define inputs of D-FlipFlop 2, outputs are P2838, 2839.			
Index:	[0] = Binector input: Set [1] = Binector input: D input [2] = Binector input: Store pulse [3] = Binector input: Reset			
Dependency:	P2801[13] assigns the D-FlipFlop to the processing sequence.			

r2838.0	BO: Q D-FF 2 / Q D-FF 2			
	Access level: 3	Calculated: -	Data type: Unsigned16	
	Unit: -	Scaling: -	Data set: -	
Description:	Displays output of D-FlipFlop 2, inputs are defined in P2837[0], P2837[1], P2837[2], P2837[3]			
Bit field:	Bit	Signal name	1 signal	0 signal
	00	Output of BO	Yes	No
Dependency:	P2801[13] assigns the D-FlipFlop to the processing sequence.			

r2839.0	BO: NOT-Q D-FF 2 / NOT-Q D-FF 2			
	Access level: 3	Calculated: -	Data type: Unsigned16	
	Unit: -	Scaling: -	Data set: -	
Description:	Displays Not-output of D-FlipFlop 2, inputs are defined in P2837[0], P2837[1], P2837[2], P2837[3]			
Bit field:	Bit	Signal name	1 signal	0 signal
	00	Output of BO	Yes	No
Dependency:	P2801[13] assigns the D-FlipFlop to the processing sequence.			

p2840[0...1]	BI: RS-FF 1 / RS-FF 1			
	Access level: 3	Calculated: -	Data type: U32 / Binary	
	Can be changed: U, T	Scaling: -	Data set: -	
	Min	Max	Factory setting	
	-	-	0	
Description:	P2840[0], P2840[1] define inputs of RS-FlipFlop 1, outputs are P2841, P2842.			

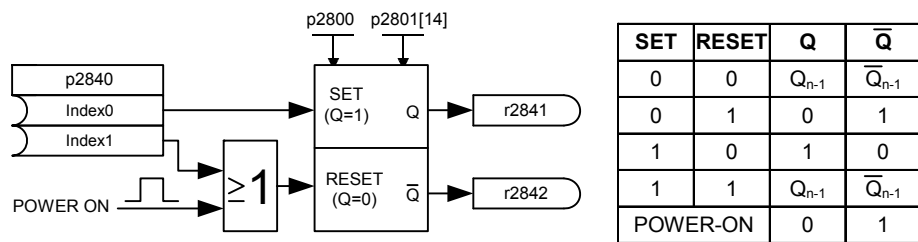

Index: [0] = Binector input: Set
[1] = Binector input: Reset
Dependency: P2801[14] assigns the RS-FlipFlop to the processing sequence.

r2841.0 **BO: Q RS-FF 1 / Q RS-FF 1**
Access level: 3 **Calculated:** - **Data type:** Unsigned16
Unit: - **Scaling:** - **Data set:** -
Description: Displays output of RS-FlipFlop 1, inputs are defined in P2840[0], P2840[1]
Bit field: **Bit** **Signal name** **1 signal** **0 signal** **FP**
 00 Output of BO Yes No -
Dependency: P2801[14] assigns the RS-FlipFlop to the processing sequence.

r2842.0 **BO: NOT-Q RS-FF 1 / NOT-Q RS-FF 1**
Access level: 3 **Calculated:** - **Data type:** Unsigned16
Unit: - **Scaling:** - **Data set:** -
Description: Displays Not-output of RS-FlipFlop 1, inputs are defined in P2840[0], P2840[1]
Bit field: **Bit** **Signal name** **1 signal** **0 signal** **FP**
 00 Output of BO Yes No -
Dependency: P2801[14] assigns the RS-FlipFlop to the processing sequence.

p2843[0...1] **BI: RS-FF 2 / RS-FF 2**
Access level: 3 **Calculated:** - **Data type:** U32 / Binary
Can be changed: U, T **Scaling:** - **Data set:** -
Min **Max** **Factory setting**
 - - 0
Description: P2843[0], P2843[1] define inputs of RS-FlipFlop 2, outputs are P2844, P2845.
Index: [0] = Binector input: Set
[1] = Binector input: Reset
Dependency: P2801[15] assigns the RS-FlipFlop to the processing sequence.

r2844.0 **BO: Q RS-FF 2 / Q RS-FF 2**
Access level: 3 **Calculated:** - **Data type:** Unsigned16
Unit: - **Scaling:** - **Data set:** -
Description: Displays output of RS-FlipFlop 2, inputs are defined in P2843[0], P2843[1]
Bit field: **Bit** **Signal name** **1 signal** **0 signal** **FP**
 00 Output of BO Yes No -
Dependency: P2801[15] assigns the RS-FlipFlop to the processing sequence.

r2845.0 **BO: NOT-Q RS-FF 2 / NOT-Q RS-FF 2**
Access level: 3 **Calculated:** - **Data type:** Unsigned16
Unit: - **Scaling:** - **Data set:** -
Description: Displays Not-output of RS-FlipFlop 2, inputs are defined in P2843[0], P2843[1]
Bit field: **Bit** **Signal name** **1 signal** **0 signal** **FP**
 00 Output of BO Yes No -
Dependency: P2801[15] assigns the RS-FlipFlop to the processing sequence.

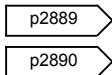
p2846[0...1]	BI: RS-FF 3 / RS-FF 3			
	Access level: 3	Calculated: -	Data type: U32 / Binary	
	Can be changed: U, T	Scaling: -	Data set: -	
	Min -	Max -	Factory setting 0	
Description:	P2846[0], P2846[1] define inputs of RS-FlipFlop 3, outputs are P2847, P2848.			
Index:	[0] = Binector input: Set [1] = Binector input: Reset			
Dependency:	P2801[16] assigns the RS-FlipFlop to the processing sequence.			
r2847.0	BO: Q RS-FF 3 / Q RS-FF 3			
	Access level: 3	Calculated: -	Data type: Unsigned16	
	Unit: -	Scaling: -	Data set: -	
Description:	Displays output of RS-FlipFlop 3, inputs are defined in P2846[0], P2846[1]			
Bit field:	Bit	Signal name	1 signal	0 signal
	00	Output of BO	Yes	No
Dependency:	P2801[16] assigns the RS-FlipFlop to the processing sequence.			
r2848.0	BO: NOT-Q RS-FF 3 / NOT-Q RS-FF 3			
	Access level: 3	Calculated: -	Data type: Unsigned16	
	Unit: -	Scaling: -	Data set: -	
Description:	Displays Not-output of RS-FlipFlop 3, inputs are defined in P2846[0], P2846[1]			
Bit field:	Bit	Signal name	1 signal	0 signal
	00	Output of BO	Yes	No
Dependency:	P2801[16] assigns the RS-FlipFlop to the processing sequence.			
p2889	CO: Fixed setpoint 1 in [%] / Fixed setp 1 %			
	Access level: 3	Calculated: -	Data type: FloatingPoint32	
	Can be changed: U, T	Scaling: -	Data set: -	
	Min -200.00 [%]	Max 200.00 [%]	Factory setting 0.00 [%]	
Description:	Fixed percent setting 1.			
	Connector Setting in %			
				
	Range : -200% ... 200%			
p2890	CO: Fixed setpoint 2 in [%] / Fixed setp 2 %			
	Access level: 3	Calculated: -	Data type: FloatingPoint32	
	Can be changed: U, T	Scaling: -	Data set: -	
	Min -200.00 [%]	Max 200.00 [%]	Factory setting 0.00 [%]	
Description:	Fixed percent setting 2.			

r3113.0...15		CO/BO: Fault Bit Array / Fault Bit Array			
	Access level: 1	Calculated: -	Data type: Unsigned16		
	Unit: -	Scaling: -	Data set: -		
Description:	Gives information about actual fault.				
Bit field:	Bit	Signal name	1 signal	0 signal	FP
	00	Inverter error	Yes	No	-
	01	Power line failure	Yes	No	-
	02	Intermediate circuit power voltage	Yes	No	-
	03	Error power electronics	Yes	No	-
	04	Convertor over temperature	Yes	No	-
	05	Earth leakage	Yes	No	-
	06	Motor overload	Yes	No	-
	07	Bus fault	Yes	No	-
	09	Fault motor sensor	Yes	No	-
	10	Fault internal communication	Yes	No	-
	11	Motor current limit	Yes	No	-
	12	Supply failure	Yes	No	-
	13	Reserved	Yes	No	-
	14	Reserved	Yes	No	-
	15	Other error	Yes	No	-
<hr/>					
p3900		End of quick commissioning / Quick commiss. end			
	Access level: 1	Calculated: -	Data type: Unsigned16		
	Can be changed: C(1)	Scaling: -	Data set: -		
	Min	Max	Factory setting		
	0	3	0		
Description:	Performs calculations necessary for optimized motor operation. After completion of calculation, P3900 and P0010 (parameter groups for commissioning) are automatically reset to their original value 0.				
Value:	0: No quick commissioning 1: End quick commissioning with factory reset 2: End quick commissioning 3: End quick commissioning only for motor data				
Dependency:	Changeable only when P0010 = 1 (quick commissioning).				
Note:	<p>P3900 = 1 :</p> <p>When setting 1 is selected, only the parameter settings carried out via the commissioning menu "Quick commissioning", are retained; all other parameter changes, including the I/O settings, are lost. Motor calculations are also performed.</p> <p>P3900 = 2 :</p> <p>When setting 2 is selected, only those parameters, which depend on the parameters in the commissioning menu "Quick commissioning" (P0010 = 1) are calculated. The I/O settings are also reset to default and the motor calculations performed.</p> <p>P3900 = 3 :</p> <p>When setting 3 is selected, only the motor and controller calculations are performed. Exiting quick commissioning with this setting saves time (for example, if only motor rating plate data have been changed).</p> <p>Calculates a variety of motor parameters, overwriting previous values. These include P0344 (motor weight), P0350 (demagnetization time), P2000 (reference frequency), P2002 (reference current).</p> <p>When transferring parameter p3900, the frequency inverter uses its processor to carry-out internal calculations. Communications - both via USS as well as via the Fieldbus - are interrupted for the time that it takes to make these calculations. This can result in the following error messages at the connected SIMATIC S7 control (communications via fieldbus):</p> <ul style="list-style-type: none"> • Parameter fault 30 • Drive fault 70 • Drive fault 75 				

When using STARTER (USS) to commission the drive system, data cannot be entered while these calculations are being made.

The faults can be acknowledged as soon as the calculations have been completed in the frequency inverter. These calculations can take up to one minute to complete.

r3930[0...4]	PS Data version / PS Data version		
	Access level: 3	Calculated: -	Data type: Unsigned16
	Unit: -	Scaling: -	Data set: -
Description:	Displays the A5E number and the ps data versions		
Index:	[0] = A5E 1st 4 digits [1] = A5E 2nd 4 digits [2] = Logistic Version [3] = Fixed Data Version [4] = Calib Data Version		
p3950	Access of hidden parameters / Access hidden par		
	Access level: 4	Calculated: -	Data type: Unsigned16
	Can be changed: U, T	Scaling: -	Data set: -
	Min 0	Max 255	Factory setting 0
Description:	Accesses special parameters for development (expert only) and factory functionality (calibration parameter).		
r3954[0...12]	CM info and GUI ID / CC info GUI ID		
	Access level: 4	Calculated: -	Data type: Unsigned16
	Unit: -	Scaling: -	Data set: -
Description:	Used to classify firmware (only for SIEMENS internal purposes).		
Index:	[0] = CM label (increment/branch) [1] = CM label (counter) [2] = CM label [3...10] = GUI ID [11] = GUI ID major release [12] = GUI ID minor release		
r3955	Version for DriveMonitor / DriveMon. version		
	Access level: 3	Calculated: -	Data type: Unsigned16
	Unit: -	Scaling: -	Data set: -
Description:	Displays the version for DriveMonitor.		
r3978	BICO counter / BICO counter		
	Access level: 4	Calculated: -	Data type: Unsigned32
	Unit: -	Scaling: -	Data set: -
Description:	Counts the number of changed BICO links		
p3981	Reset active fault / Reset active fault		
	Access level: 4	Calculated: -	Data type: Unsigned16
	Can be changed: T	Scaling: -	Data set: -
	Min 0	Max 1	Factory setting 0
Description:	Resets active faults when changed from 0 to 1.		
Value:	0: No fault reset 1: Reset fault		
Note:	See P0947 (last fault code) Automatically reset to 0.		

p3984	Client telegram off time / Client tel. off ti		
	Access level: 3	Calculated: -	Data type: Unsigned16
	Can be changed: T	Scaling: -	Data set: -
	Min 100 [ms]	Max 10000 [ms]	Factory setting 1000 [ms]
Description:	Defines time after which a fault will be generated (7220) if no telegram is received from the client.		
Dependency:	Setting 0 = watchdog disabled		
r3986[0...1]	Number of parameters / No. of parameters		
	Access level: 4	Calculated: -	Data type: Unsigned16
	Unit: -	Scaling: -	Data set: -
Description:	Number of parameters on the drive.		
Index:	[0] = Read only [1] = Read & write		
p7841[0...5]	PM serial no hot swap check / PM Serialno		
	Access level: 3	Calculated: -	Data type: Unsigned16
	Can be changed: T	Scaling: -	Data set: -
	Min 0	Max 65535	Factory setting 0
Description:	Reads the power module serial number, which is stored in the control unit. At power up these serial number are verified, if any swapping of the CU or the PM had been taken place.		
Index:	[0] = Production site [1] = Production year after 2000 [2] = Production month [3] = Production day [4] = Production number per day [5] = Type - not used on all drives		
Note:	The parameter cannot be changed.		
p7844	Acceptance Test, Confirmation / Ack Accept. Test		
	Access level: 3	Calculated: -	Data type: Unsigned16
	Can be changed: T	Scaling: -	Data set: -
	Min 0	Max 2	Factory setting 0
Description:	After an automatic download from MMC at startup, this parameter will be automatically set to 1. Also a fault F0395 will be set. With setting to P7844 = 0 you quit F0395 and confirm the parameter settings. Setting this parameter to 2 is only possible if an automatic download has been performed at startup. In this case the download will be undone and the previously stored parameters will be enabled.		
Value:	0: Acceptance Test / Confirmation ok. 1: Acceptance Test / Confirmation is pending 2: Undo Clone		
Note:	If no automatic download from MMC has been performed during startup the setting 2 is not possible.		

p8458	Clone Control / Clone Control		
	Access level: 3	Calculated: -	Data type: Unsigned16
	Can be changed: T	Scaling: -	Data set: -
	Min	Max	Factory setting
	0	2	1
Description:	This parameter specifies whether a cloning at startup will be performed. The File clone00.bin will be used. If no MMC is inserted there will be a normal startup.		
Value:	0: No Startup Clone 1: Once Startup Clone 2: Always Startup Clone		
Note:	Default value is 1. After first cloning the parameter is set to 0. If a MMC is inserted without a valid file the drive will set a fault F0061 / F0063 / F0064 which can only be cleared by a powercycle. The fault is signalled by a flashing RUN LED (Commissioning). The SF LED is not activated. P8458 will not be changed by performing a factory reset.		

2.3 Command and Drive Data Sets – Overview

2.3.1 Command Data Sets (CDS)

Product: G110D, Version: 3700000, Language: eng, Type: CDS

p0700[0...2]	Selection of command source / Command source sel
p0701[0...2]	Function of digital input 0 / Function of DI0
p0702[0...2]	Function of digital input 1 / Function of DI1
p0703[0...2]	Function of digital input 2 / Function of DI2
p0704[0...2]	Function of digital input 3 / Function of DI3
p0712[0...2]	Analog / digital input 0 / Ana/digi input 0
p0719[0...2]	Selection of cmd. & freq. setp. / Cmd.&freq.setp.sel
p0727[0...2]	Selection of 2/3-wire method / 2/3-wire selection
p0800[0...2]	BI: Download parameter set 0 / Dwnl.par.set 0
p0801[0...2]	BI: Download parameter set 1 / Dwnl.par.set 1
p0840[0...2]	BI: ON/OFF1 / ON/OFF1
p0842[0...2]	BI: ON reverse/OFF1 / ON reverse/OFF1
p0844[0...2]	BI: 1. OFF2 / 1. OFF2
p0845[0...2]	BI: 2. OFF2 / 2. OFF2
p0848[0...2]	BI: 1. OFF3 / 1. OFF3
p0849[0...2]	BI: 2. OFF3 / 2. OFF3
p0852[0...2]	BI: Pulse enable / Pulse enable
p0881[0...2]	BI: Quick Stop ON Source 1 / Quick Stop S1
p0882[0...2]	BI: Quick Stop ON Source 2 / Quick Stop S2
p0883[0...2]	BI: Quick Stop Override / QS Override
p0886[0...2]	Quick Stop Input Type / QS Input Type
p1000[0...2]	Selection of frequency setpoint / Freq setp. select.
p1020[0...2]	BI: Fixed freq. selection Bit 0 / FF sel. Bit 0
p1021[0...2]	BI: Fixed freq. selection Bit 1 / FF sel. Bit 1
p1022[0...2]	BI: Fixed freq. selection Bit 2 / FF sel. Bit 2
p1023[0...2]	BI: Fixed freq. selection Bit 3 / FF sel. Bit 3
p1035[0...2]	BI: Enable MOP (UP-command) / Enable MOP(UP)
p1036[0...2]	BI: Enable MOP (DOWN-command) / Enable MOP(DWN)
p1041[0...2]	BI: MOP select setpoint automatically/manually / Setp. auto/manu
p1042[0...2]	CI: MOP auto setpoint / MOP auto setpoint
p1055[0...2]	BI: Enable JOG right / Enable JOG ->
p1056[0...2]	BI: Enable JOG left / Enable JOG <-
p1070[0...2]	CI: Main setpoint / Main setpoint
p1071[0...2]	CI: Main setpoint scaling / Main setp scal
p1074[0...2]	BI: Disable additional setpoint / Disab.add.setp
p1075[0...2]	CI: Additional setpoint / Add. setpoint
p1076[0...2]	CI: Additional setpoint scaling / Add. setp.scal
p1110[0...2]	BI: Inhibit neg. freq. setpoint / Inh. neg. setp
p1113[0...2]	BI: Reverse / Reverse
p1124[0...2]	BI: Enable JOG ramp times / Enable JOG ramp
p1140[0...2]	BI: RFG enable / RFG enable
p1141[0...2]	BI: RFG start / RFG start
p1142[0...2]	BI: RFG enable setpoint / RFG enable setp
p1218[0...2]	BI: MHB override / MHB override
p1230[0...2]	BI: Enable DC braking / Enable DC brk.
p1330[0...2]	CI: Voltage setpoint / Voltage setp.
p2103[0...2]	BI: 1. Faults acknowledgement / 1. Faults ackn

p2104[0...2]	BI: 2. Faults acknowledgement / 2. Faults ackn
p2106[0...2]	BI: External fault / External fault
p2200[0...2]	BI: Enable PID controller / Enab. PID ctrl
p2220[0...2]	BI: Fixed PID setp. select Bit 0 / PID setp->Bit 0
p2221[0...2]	BI: Fixed PID setp. select Bit 1 / PID setp->Bit 1
p2222[0...2]	BI: Fixed PID setp. select Bit 2 / PID setp->Bit 2
p2223[0...2]	BI: Fixed PID setp. select Bit 3 / PID setp->Bit 3
p2235[0...2]	BI: Enable PID-MOP (UP-cmd) / PID-MOP (UP)
p2236[0...2]	BI: Enable PID-MOP (DOWN-cmd) / PID-MOP (DWN)
p2241[0...2]	BI: PID-MOP select setpoint auto/manu / Setp. auto/manu
p2242[0...2]	CI: PID-MOP auto setpoint / PMOP auto setpoint
p2243[0...2]	BI: PID-MOP accept rampgenerator setpoint / PMOP acc RFG setpo
p2244[0...2]	CI: PID-MOP rampgenerator setpoint / PMOP RFG setpoint
p2253[0...2]	CI: PID setpoint / PID setpoint
p2254[0...2]	CI: PID trim source / PID trim source
p2264[0...2]	CI: PID feedback / PID feedback
p2803[0...2]	Enable FastFFBs / Enable FastFFBs

2.3.2 Drive Data Sets (DDS)

Product: G110D, Version: 3700000, Language: eng, Type: DDS

r0035[0...2]	CO: Act. motor temperature / Act. mot.temp.
p0291[0...2]	Inverter protection / Inverter protect.
p0300[0...2]	Select motor type / Select motor type
p0304[0...2]	Rated motor voltage / Rated mot. voltage
p0305[0...2]	Rated motor current / Rated mot. current
p0307[0...2]	Rated motor power / Rated motor power
p0308[0...2]	Rated motor cosPhi / Rated mot. cosPhi
p0309[0...2]	Rated motor efficiency / Rated efficiency
p0310[0...2]	Rated motor frequency / Rated motor freq.
p0311[0...2]	Rated motor speed / Rated motor speed
r0313[0...2]	Motor pole pairs / Motor pole pairs
p0314[0...2]	Motor pole pair number / Motor pole pair no
p0320[0...2]	Motor magnetizing current / Motor magnet. cur.
r0330[0...2]	Rated motor slip / Rated motor slip
r0331[0...2]	Rated magnetization current / Rated magnet. cur.
r0332[0...2]	Rated power factor / Rated power factor
r0333[0...2]	Rated motor torque / Rated motor torque
p0335[0...2]	Motor cooling / Motor cooling
p0340[0...2]	Calculation of motor parameters / Calc of mot.params
p0341[0...2]	Motor inertia [kg*m^2] / Inertia [kg*m^2]
p0342[0...2]	Total/motor inertia ratio / Tot/mot inert.rat.
p0344[0...2]	Motor weight / Motor weight
r0345[0...2]	Motor start-up time / Mot. start-up time
p0346[0...2]	Magnetization time / Magnetization time
p0347[0...2]	Demagnetization time / Demagnet. time
p0350[0...2]	Stator resistance (line) / Stator res. (L)
p0352[0...2]	Cable resistance / Cable resistance
p0354[0...2]	Rotor resistance / Rotor resistance
p0356[0...2]	Stator leakage inductance / Stator leak.induct
p0358[0...2]	Rotor leakage inductance / Rotor leak.induct.
p0360[0...2]	Main inductance / Main inductance
p0362[0...2]	Magnetizing curve flux 1 / Magnet.curve flux1

p0363[0...2]	Magnetizing curve flux 2 / Magnet.curve flux2
p0364[0...2]	Magnetizing curve flux 3 / Magnet.curve flux3
p0365[0...2]	Magnetizing curve flux 4 / Magnet.curve flux4
p0366[0...2]	Magnetizing curve imag 1 / Magnet.curve imag1
p0367[0...2]	Magnetizing curve imag 2 / Magnet.curve imag2
p0368[0...2]	Magnetizing curve imag 3 / Magnet.curve imag3
p0369[0...2]	Magnetizing curve imag 4 / Magnet.curve imag4
r0370[0...2]	Stator resistance [%] / Stator res. [%]
r0372[0...2]	Cable resistance [%] / Cable res. [%]
r0373[0...2]	Rated stator resistance [%] / Rated stat.res.[%]
r0374[0...2]	Rotor resistance [%] / Rotor res. [%]
r0376[0...2]	Rated rotor resistance [%] / Rated rot. res.[%]
r0377[0...2]	Total leakage reactance [%] / Tot.leak.react.[%]
r0382[0...2]	Main reactance [%] / Main reactance [%]
r0384[0...2]	Rotor time constant / Rotor time const.
r0386[0...2]	Total leakage time constant / Total leak. Tconst
p0500[0...2]	Technological application / Techn. application
p0601[0...2]	Motor temperature sensor / Motor temp. sensor
p0604[0...2]	Threshold motor temperature / Thresh. mot. temp.
p0610[0...2]	Motor I2t temperature reaction / I2t temp. reaction
p0622[0...2]	Magnetizing time for temp id after start up / Magnet. t temp id
p0625[0...2]	Ambient motor temperature / Ambient mot. temp.
p0626[0...2]	Overttemperature stator iron / Overtemp.stat.iron
p0627[0...2]	Overttemperature stator winding / Overtemp.stat.wind
p0628[0...2]	Overttemperature rotor winding / Overtemp.rot. wind
r0630[0...2]	CO: Motor model ambient temperature / Mot. model amb. te
r0631[0...2]	CO: Stator iron temperature / Stat.iron temp
r0632[0...2]	CO: Stator winding temperature / Stat.wind.temp
r0633[0...2]	CO: Rotor winding temperature / Rot. wind.temp
p0640[0...2]	Motor overload factor [%] / Motor ovl fact [%]
p1001[0...2]	Fixed frequency 1 / Fixed frequency 1
p1002[0...2]	Fixed frequency 2 / Fixed frequency 2
p1003[0...2]	Fixed frequency 3 / Fixed frequency 3
p1004[0...2]	Fixed frequency 4 / Fixed frequency 4
p1005[0...2]	Fixed frequency 5 / Fixed frequency 5
p1006[0...2]	Fixed frequency 6 / Fixed frequency 6
p1007[0...2]	Fixed frequency 7 / Fixed frequency 7
p1008[0...2]	Fixed frequency 8 / Fixed frequency 8
p1009[0...2]	Fixed frequency 9 / Fixed frequency 9
p1010[0...2]	Fixed frequency 10 / Fixed frequency 10
p1011[0...2]	Fixed frequency 11 / Fixed frequency 11
p1012[0...2]	Fixed frequency 12 / Fixed frequency 12
p1013[0...2]	Fixed frequency 13 / Fixed frequency 13
p1014[0...2]	Fixed frequency 14 / Fixed frequency 14
p1015[0...2]	Fixed frequency 15 / Fixed frequency 15
p1016[0...2]	Fixed frequency mode / FF mode
p1031[0...2]	MOP mode / MOP mode
p1040[0...2]	Setpoint of the MOP / MOP setpoint
p1047[0...2]	MOP ramp-up time of the RFG / MOP ramp-up time
p1048[0...2]	MOP ramp-down time of the RFG / MOP rampdown time
p1058[0...2]	JOG frequency / JOG frequency
p1059[0...2]	JOG frequency left / JOG frequency <-
p1060[0...2]	JOG ramp-up time / JOG ramp-up time

p1061[0...2]	JOG ramp-down time / JOG ramp-down time
p1080[0...2]	Min. frequency / Min. frequency
p1082[0...2]	Max. frequency / Max. frequency
p1091[0...2]	Skip frequency / Skip frequency
p1092[0...2]	Skip frequency 2 / Skip frequency 2
p1093[0...2]	Skip frequency 3 / Skip frequency 3
p1094[0...2]	Skip frequency 4 / Skip frequency 4
p1101[0...2]	Skip frequency bandwidth / Skipfreq bandwidth
p1120[0...2]	Ramp-up time / Ramp-up time
p1121[0...2]	Ramp-down time / Ramp-down time
p1130[0...2]	Ramp-up initial rounding time / Ramp-up ini. Trnd
p1131[0...2]	Ramp-up final rounding time / Ramp-up final Trnd
p1132[0...2]	Ramp-down initial rounding time / Ramp-dwn ini. Trnd
p1133[0...2]	Ramp-down final rounding time / Ramp-dwn fin. Trnd
p1134[0...2]	Rounding type / Rounding type
p1135[0...2]	OFF3 ramp-down time / OFF3 ramp-dwn time
p1202[0...2]	Motor-current: Flying start / Mot. cur: Flystart
p1203[0...2]	Search rate: Flying start / SrchRate: Flystart
p1227[0...2]	Zero speed detection monitoring time / Zero speed time
p1232[0...2]	DC braking current / DC braking current
p1233[0...2]	Duration of DC braking / DC brak. duration
p1234[0...2]	DC braking start frequency / DC brk. start freq
p1240[0...2]	Configuration of Vdc controller / Vdc controller
p1243[0...2]	Dynamic factor of Vdc-max / Vdc-max dyn. fact.
p1250[0...2]	Gain of Vdc-controller / Gain of Vdc ctrl.
p1251[0...2]	Integration time Vdc-controller / Int. time Vdc ctrl
p1252[0...2]	Differential time Vdc-controller / Diff.time Vdc ctrl
p1253[0...2]	Vdc-controller output limitation / Vdc ctrl outp. lim
p1300[0...2]	Control mode / Control mode
p1310[0...2]	Continuous boost / Continuous boost
p1311[0...2]	Acceleration boost / Acceleration boost
p1312[0...2]	Starting boost / Starting boost
p1316[0...2]	Boost end frequency / Boost end freq.
p1320[0...2]	Programmable V/f freq. coord. 1 / V/f freq. coord. 1
p1321[0...2]	Programmable V/f volt. coord. 1 / V/f volt. coord. 1
p1322[0...2]	Programmable V/f freq. coord. 2 / V/f freq. coord. 2
p1323[0...2]	Programmable V/f volt. coord. 2 / V/f volt. coord. 2
p1324[0...2]	Programmable V/f freq. coord. 3 / V/f freq. coord. 3
p1325[0...2]	Programmable V/f volt. coord. 3 / V/f volt. coord. 3
p1333[0...2]	Start frequency for FCC / Start freq for FCC
p1334[0...2]	Slip compensation activation range / Slip c. act. range
p1335[0...2]	Slip compensation / Slip compensation
p1336[0...2]	Slip limit / Slip limit
p1338[0...2]	Resonance damping gain V/f / Res.damp. gain V/f
p1340[0...2]	Imax controller prop. gain / Imax ctrl prp gain
p1341[0...2]	Imax controller integral time / Imax ctrl int time
p1345[0...2]	Imax voltage ctrl. prop. gain / Imax volt prp gain
p1346[0...2]	Imax voltage ctrl. integral time / Imax volt int time
p1350[0...2]	Voltage soft start / Voltage soft start
p1800[0...2]	Pulse frequency / Pulse frequency
p1803[0...2]	Max. modulation / Max. modulation
p1820[0...2]	Reverse output phase sequence / Rev.outp.phase seq
p1909[0...2]	Ctrl. word of motor data ident. / Ctrl.mot.data id.

p2000[0...2]	Reference frequency / Reference freq.
p2001[0...2]	Reference voltage / Reference voltage
p2002[0...2]	Reference current / Reference current
p2003[0...2]	Reference torque / Reference torque
p2004[0...2]	Reference power / Reference power
p2150[0...2]	Hysteresis frequency f_hys / Hyst. freq. f_hys
p2151[0...2]	Cl: Speed setpoint for messages / n-Set for msg
p2155[0...2]	Threshold frequency f_1 / Threshold freq f_1
p2156[0...2]	Delay time of threshold freq f_1 / Delay time of f_1
p2162[0...2]	Hysteresis freq. for overspeed / Overspd. hyst.freq
p2164[0...2]	Hysteresis frequency deviation / Hyster freq deviat
p2166[0...2]	Delay time ramp up completed / Delay_T rampUpCmpl
p2167[0...2]	Switch-off frequency f_off / SwOff freq. f_off
p2168[0...2]	Delay time T_off / Delay time T_off
p2170[0...2]	Threshold current I_thresh / Threshold current
p2171[0...2]	Delay time current / Delay time current
p2172[0...2]	Threshold DC-link voltage / Vdc threshold
p2173[0...2]	Delay time DC-link voltage / Vdc delay time
p2177[0...2]	Delay time for motor is blocked / Delay_T MotBlocked
p2181[0...2]	Belt failure detection mode / Belt fail detect
p2182[0...2]	Belt threshold frequency 1 / Belt threshold f_1
p2183[0...2]	Belt threshold frequency 2 / Belt threshold f_2
p2184[0...2]	Belt threshold frequency 3 / Belt threshold f_3
p2185[0...2]	Upper torque threshold 1 / Upper trq. thresh1
p2186[0...2]	Lower torque threshold 1 / Lower trq. thresh1
p2187[0...2]	Upper torque threshold 2 / Upper trq. thresh2
p2188[0...2]	Lower torque threshold 2 / Lower trq. thresh2
p2189[0...2]	Upper torque threshold 3 / Upper trq. thresh3
p2190[0...2]	Lower torque threshold 3 / Lower trq. thresh3
p2192[0...2]	Time delay for belt failure / Belt fail delay_T
p2201[0...2]	Fixed PID setpoint 1 / Fixed PID setp. 1
p2202[0...2]	Fixed PID setpoint 2 / Fixed PID setp. 2
p2203[0...2]	Fixed PID setpoint 3 / Fixed PID setp. 3
p2204[0...2]	Fixed PID setpoint 4 / Fixed PID setp. 4
p2205[0...2]	Fixed PID setpoint 5 / Fixed PID setp. 5
p2206[0...2]	Fixed PID setpoint 6 / Fixed PID setp. 6
p2207[0...2]	Fixed PID setpoint 7 / Fixed PID setp. 7
p2208[0...2]	Fixed PID setpoint 8 / Fixed PID setp. 8
p2209[0...2]	Fixed PID setpoint 9 / Fixed PID setp. 9
p2210[0...2]	Fixed PID setpoint 10 / Fixed PID setp. 10
p2211[0...2]	Fixed PID setpoint 11 / Fixed PID setp. 11
p2212[0...2]	Fixed PID setpoint 12 / Fixed PID setp. 12
p2213[0...2]	Fixed PID setpoint 13 / Fixed PID setp. 13
p2214[0...2]	Fixed PID setpoint 14 / Fixed PID setp. 14
p2215[0...2]	Fixed PID setpoint 15 / Fixed PID setp. 15
p2216[0...2]	Fixed PID setpoint mode / Fix.PID Mode
p2231[0...2]	PID-MOP mode / PID-MOP mode.
p2240[0...2]	Setpoint of PID-MOP / Setp. of PID-MOP
p2247[0...2]	PID-MOP ramp-up time of the RFG / PMOP ramp-up time
p2248[0...2]	PID-MOP ramp-down time of the RFG / PMOP rampdown time

2.4 Connector/Binector (BICO)-Parameters

2.4.1 Binector Input Parameters

Product: G110D, Version: 3700000, Language: eng, Type: BI

p0800[0...2]	BI: Download parameter set 0 / Dwnl.par.set 0
p0801[0...2]	BI: Download parameter set 1 / Dwnl.par.set 1
p0806	BI: Inhibit panel access / Inhibit panel acce
p0810	BI: CDS bit 0 (Hand/Auto) / CDS bit 0
p0811	BI: CDS bit 1 / CDS bit 1
p0820	BI: DDS bit 0 / DDS bit 0
p0821	BI: DDS bit 1 / DDS bit 1
p0840[0...2]	BI: ON/OFF1 / ON/OFF1
p0842[0...2]	BI: ON reverse/OFF1 / ON reverse/OFF1
p0844[0...2]	BI: 1. OFF2 / 1. OFF2
p0845[0...2]	BI: 2. OFF2 / 2. OFF2
p0848[0...2]	BI: 1. OFF3 / 1. OFF3
p0849[0...2]	BI: 2. OFF3 / 2. OFF3
p0852[0...2]	BI: Pulse enable / Pulse enable
p0881[0...2]	BI: Quick Stop ON Source 1 / Quick Stop S1
p0882[0...2]	BI: Quick Stop ON Source 2 / Quick Stop S2
p0883[0...2]	BI: Quick Stop Override / QS Override
p1020[0...2]	BI: Fixed freq. selection Bit 0 / FF sel. Bit 0
p1021[0...2]	BI: Fixed freq. selection Bit 1 / FF sel. Bit 1
p1022[0...2]	BI: Fixed freq. selection Bit 2 / FF sel. Bit 2
p1023[0...2]	BI: Fixed freq. selection Bit 3 / FF sel. Bit 3
p1035[0...2]	BI: Enable MOP (UP-command) / Enable MOP(UP)
p1036[0...2]	BI: Enable MOP (DOWN-command) / Enable MOP(DWN)
p1041[0...2]	BI: MOP select setpoint automatically/manually / Setp. auto/manu
p1055[0...2]	BI: Enable JOG right / Enable JOG ->
p1056[0...2]	BI: Enable JOG left / Enable JOG <-
p1074[0...2]	BI: Disable additional setpoint / Disab.add.setp
p1110[0...2]	BI: Inhibit neg. freq. setpoint / Inh. neg. setp
p1113[0...2]	BI: Reverse / Reverse
p1124[0...2]	BI: Enable JOG ramp times / Enable JOG ramp
p1140[0...2]	BI: RFG enable / RFG enable
p1141[0...2]	BI: RFG start / RFG start
p1142[0...2]	BI: RFG enable setpoint / RFG enable setp
p1218[0...2]	BI: MHB override / MHB override
p1230[0...2]	BI: Enable DC braking / Enable DC brk.
p2063[0...5]	BI: ASI DigIn / ASI DigIn
p2103[0...2]	BI: 1. Faults acknowledgement / 1. Faults ackn
p2104[0...2]	BI: 2. Faults acknowledgement / 2. Faults ackn
p2106[0...2]	BI: External fault / External fault
p2200[0...2]	BI: Enable PID controller / Enab. PID ctrl
p2220[0...2]	BI: Fixed PID setp. select Bit 0 / PID setp->Bit 0
p2221[0...2]	BI: Fixed PID setp. select Bit 1 / PID setp->Bit 1
p2222[0...2]	BI: Fixed PID setp. select Bit 2 / PID setp->Bit 2
p2223[0...2]	BI: Fixed PID setp. select Bit 3 / PID setp->Bit 3
p2235[0...2]	BI: Enable PID-MOP (UP-cmd) / PID-MOP (UP)
p2236[0...2]	BI: Enable PID-MOP (DOWN-cmd) / PID-MOP (DWN)
p2241[0...2]	BI: PID-MOP select setpoint auto/manu / Setp. auto/manu

p2243[0...2]	BI: PID-MOP accept rampgenerator setpoint / PMOP acc RFG setpo
p2810[0...1]	BI: AND 1 / AND 1
p2812[0...1]	BI: AND 2 / AND 2
p2814[0...1]	BI: AND 3 / AND 3
p2816[0...1]	BI: OR 1 / OR 1
p2818[0...1]	BI: OR 2 / OR 2
p2820[0...1]	BI: OR 3 / OR 3
p2822[0...1]	BI: XOR 1 / XOR 1
p2824[0...1]	BI: XOR 2 / XOR 2
p2826[0...1]	BI: XOR 3 / XOR 3
p2828	BI: NOT 1 / NOT 1
p2830	BI: NOT 2 / NOT 2
p2832	BI: NOT 3 / NOT 3
p2834[0...3]	BI: D-FF 1 / D-FF 1
p2837[0...3]	BI: D-FF 2 / D-FF 2
p2840[0...1]	BI: RS-FF 1 / RS-FF 1
p2843[0...1]	BI: RS-FF 2 / RS-FF 2
p2846[0...1]	BI: RS-FF 3 / RS-FF 3

2.4.2 Connector Input Parameters

Product: G110D, Version: 3700000, Language: eng, Type: CI

p0095[0...9]	CI: Display PZD signals / PZD signals
p1042[0...2]	CI: MOP auto setpoint / MOP auto setpoint
p1070[0...2]	CI: Main setpoint / Main setpoint
p1071[0...2]	CI: Main setpoint scaling / Main setp scal
p1075[0...2]	CI: Additional setpoint / Add. setpoint
p1076[0...2]	CI: Additional setpoint scaling / Add. setp.scal
p1330[0...2]	CI: Voltage setpoint / Voltage setp.
p2016[0...7]	CI: PZD to USS on RS232 / PZD->USS
p2061[0...1]	CI: CTT2 data to ASI / CTT2 data to ASI
p2151[0...2]	CI: Speed setpoint for messages / n-Set for msg
p2242[0...2]	CI: PID-MOP auto setpoint / PMOP auto setpoint
p2244[0...2]	CI: PID-MOP rampgenerator setpoint / PMOP RFG setpoint
p2253[0...2]	CI: PID setpoint / PID setpoint
p2254[0...2]	CI: PID trim source / PID trim source
p2264[0...2]	CI: PID feedback / PID feedback

2.4.3 Binector Output Parameters

Product: G110D, Version: 3700000, Language: eng, Type: BO

r0807.0	BO: Displays client access / Displays client ac
r1025.0	BO: Fixed frequency status / FF Status
r2032.0...15	BO: CtrlWrd1 from USS on RS232 / CtrlWd1 <- USS
r2033.0...15	BO: CtrlWrd2 from USS on RS232 / CtrlWd2 <- USS
r2090.0...15	BO: Control word 1 from Fieldbus / CtrlWd1 <- FB
r2091.0...15	BO: Control word 2 from Fieldbus / CtrlWd2 <- FB
r2225.0	BO: PID Fixed frequency status / PID FF Status
r2811.0	BO: AND 1 / AND 1
r2813.0	BO: AND 2 / AND 2
r2815.0	BO: AND 3 / AND 3
r2817.0	BO: OR 1 / OR 1

r2819.0	BO: OR 2 / OR 2
r2821.0	BO: OR 3 / OR 3
r2823.0	BO: XOR 1 / XOR 1
r2825.0	BO: XOR 2 / XOR 2
r2827.0	BO: XOR 3 / XOR 3
r2829.0	BO: NOT 1 / NOT 1
r2831.0	BO: NOT 2 / NOT 2
r2833.0	BO: NOT 3 / NOT 3
r2835.0	BO: Q D-FF 1 / Q D-FF 1
r2836.0	BO: NOT-Q D-FF 1 / NOT-Q D-FF 1
r2838.0	BO: Q D-FF 2 / Q D-FF 2
r2839.0	BO: NOT-Q D-FF 2 / NOT-Q D-FF 2
r2841.0	BO: Q RS-FF 1 / Q RS-FF 1
r2842.0	BO: NOT-Q RS-FF 1 / NOT-Q RS-FF 1
r2844.0	BO: Q RS-FF 2 / Q RS-FF 2
r2845.0	BO: NOT-Q RS-FF 2 / NOT-Q RS-FF 2
r2847.0	BO: Q RS-FF 3 / Q RS-FF 3
r2848.0	BO: NOT-Q RS-FF 3 / NOT-Q RS-FF 3

2.4.4 Connector Output Parameters

Product: G110D, Version: 3700000, Language: eng, Type: CO

r0020	CO: Freq. setpoint before RFG / Setp before RFG
r0021	CO: Act. filtered frequency / Act. filt. freq.
r0024	CO: Act. filt. output frequency / Act. outp. freq
r0025	CO: Act. output voltage / Act.outp. volt
r0026[0]	CO: Act. filtered DC-link volt. / Act. fil. Vdc
r0027	CO: Act. output current / Act. outp. cur
r0031	CO: Act. filtered torque / Act fil torque
r0032	CO: Act. filtered power / Act fil. power
r0035[0...2]	CO: Act. motor temperature / Act. mot.temp.
r0036	CO: Inverter overload utilization / Invert ovl util
r0037[0...2]	CO: Inverter temperature [°C] / Inverter temp.
r0038	CO: Fil. power factor / Fil.power fact
r0039	CO: Energy consumpt. meter [kWh] / Energy meter
r0051[0...1]	CO: Active Drive Dataset (DDS) / Active DDS
r0066	CO: Act. output frequency / Act. outp freq
r0067	CO: Act. output current limit / Outp cur limit
r0068	CO: Output current / Output current
r0069[0...5]	CO: Act. phase currents / Act. phase cur
r0070	CO: Act. DC-link voltage / Act. Vdc
r0071	CO: Max. output voltage / Max. outp.volt
r0072	CO: Act. output voltage / Act. outp.volt
r0074	CO: Act. modulation / Act modulation
r0080	CO: Act. torque / Act. torque
r0084	CO: Act. air gap flux / Air gap flux
r0085	CO: Act. re-active current / Act.re-active cur
r0086	CO: Act. active current / Act.active cur
r0087	CO: Act. power factor / Act.power fact
r0094	CO: Transformation angle / Transf. angle
r0395	CO: Total stator resistance [%] / Total stat.res
r0630[0...2]	CO: Motor model ambient temperature / Mot. model amb. te
r0631[0...2]	CO: Stator iron temperature / Stat.iron temp

r0632[0...2]	CO: Stator winding temperature / Stat.wind.temp
r0633[0...2]	CO: Rotor winding temperature / Rot. wind.temp
r0755[0]	CO: Act. AI after scal. [4000h] / CO:AI scal[4000h]
r0947[0...63]	CO: Last fault code / Last fault code
r0949[0...63]	CO: Fault value / Fault value
r1024	CO: Act. fixed frequency / Act. FF
r1045	CO: MOP input frequency of the RFG / MOP RFG input
r1050	CO: Act. Output freq. of the MOP / MOP outp.freq.
r1078	CO: Total frequency setpoint / Tot. freq.setp
r1079	CO: Selected frequency setpoint / Sel. freq.setp
r1114	CO: Freq. setp. after dir. ctrl. / Setp<-dir.ctrl.
r1119	CO: Freq. setpoint before RFG / Setp before RFG
r1170	CO: Frequency setpoint after RFG / Setp. after RFG
r1242	CO: Switch-on level of Vdc-max / Vdc-max ON lev
r1315	CO: Total boost voltage / Total boost V
r1337	CO: V/f slip frequency / V/f slip freq.
r1343	CO: I _{max} controller freq. output / I _{max} ctrl Foutp
r1344	CO: I _{max} controller volt. output / I _{max} ctrl Voutp
r1801[0...1]	CO: Pulse frequency / Pulse frequency
r2015[0...7]	CO: PZD from USS on RS232 / PZD<-USS
r2059[0...4]	CO: Displays SOL link stats for Sol Master / Disp SOL stats
r2062[0...1]	CO: CTT2 from ASI / CTT2 from ASI
r2110[0...3]	CO: Warning number / Warning number
r2224	CO: Act. fixed PID setpoint / Fixed.PID setp
r2245	CO: PID-MOP input frequency of the RFG / PMOP RFG input
r2250	CO: Output setpoint of PID-MOP / PMOP outp. setp
r2260	CO: PID setpoint after PID-RFG / PID setp <-RFG
r2262	CO: Filtered PID setp. after RFG / Filt. PID setp
r2266	CO: PID filtered feedback / PID filt.fdbck
r2272	CO: PID scaled feedback / PID scal fdbck
r2273	CO: PID error / PID error
r2294	CO: Act. PID output / Act.PID output
p2889	CO: Fixed setpoint 1 in [%] / Fixed setp 1 %
p2890	CO: Fixed setpoint 2 in [%] / Fixed setp 2 %

2.4.5

Connector/Binector Output Parameters

Product: G110D, Version: 3700000, Language: eng, Type: CO/BO

r0019.2...9	CO/BO: OP control word / OP CtrlWd
r0050	CO/BO: Active Command Dataset / Active CDS
r0052.0...15	CO/BO: Act. status word 1 / Act StatWd1
r0053.0...15	CO/BO: Act. status word 2 / Act StatWd2
r0054.0...15	CO/BO: Act. control word 1 / Act CtrlWd1
r0055.0...15	CO/BO: Act. control word 2 / Act CtrlWd2
r0056.0...14	CO/BO: Status of motor control / Stat MotCtrl
r0722.0...11	CO/BO: Digital input values / Dig.inp.val
r0751.0...8	CO/BO: Status word of AI / AI status Wd
r0885.0...4	CO/BO: Quick Stop Status / Quick Stop Status
r2067.0...11	CO/BO: Digital input values Status / Dig.inp.val
r2197.0...12	CO/BO: Monitoring word 1 / Monitor Wd1
r2198.0...12	CO/BO: Monitoring word 2 / Monitor Wd2
r3113.0...15	CO/BO: Fault Bit Array / Fault Bit Array

2.5 Quick commissioning (p0010 = 1)

The following parameters are necessary for quick commissioning (p0010 = 1).

Table 2-3 Quick commissioning (p0010 = 1)

Par.-No.	Name	Access level	Can be changed
P0100	Europe / North America	1	C
P0205	Inverter application	3	C
P0300	Select motor type	2	C
P0304	Rated motor voltage	1	C
P0305	Rated motor current	1	C
P0307	Rated motor power	1	C
P0308	Rated motor cosPhi	1	C
P0309	Rated motor efficiency	1	C
P0310	Rated motor frequency	1	C
P0311	Rated motor speed	1	C
P0314	Motor pole pair number	3	C
P0320	Motor magnetizing current	3	CT
P0335	Motor cooling	2	CT
P0500	Technological application	3	CT
P0625	Ambiant motor temperature	3	CUT
P0640	Motor overload factor [%]	2	CUT
P0700	Selection of command source	1	CT
P0727	Selection of 2/3-wire method	2	CT
P1000	Selection of frequency setpoint	1	CT
P1080	Min. frequency	1	CUT
P1082	Max. frequency	1	CT
P1120	Ramp-up time	1	CUT
P1121	Ramp-down time	1	CUT
P1135	OFF3 ramp-down time	2	CUT
P1300	Control mode	2	CT
P1900	Select motor data identification	2	CT
P3900	End of quick commissioning	1	C

When p0010 = 1 is chosen, p0003 (user access level) can be used to select the parameters to be accessed.

At the end of the quick commissioning sequence, set p3900 = 1 to carry out the necessary motor calculations and clear all other parameters (not included in p0010 = 1) to their default settings.

Note

This applies only in Quick Commissioning mode.

Function diagrams

3

Contents

3.1	Contents: function diagrams	3-174
3.2	Symbols in function diagrams	3-176
3.3	Overview	3-178
3.4	External Interfaces	3-181
3.5	Internal Setpoint Source	3-186
3.6	Technology Functions	3-193
3.7	Free Function Blocks	3-204
3.8	Setpoint Channel	3-207
3.9	V/f Control	3-212
3.10	Display values	3-214

3.1 Contents: function diagrams

3.2 Symbols in function diagrams	3-176
0010 – Symbols in function diagrams	3-177
3.3 Overview	3-178
1100 – General Overview	3-179
1200 – Connection of External and Internal Setpoints	3-180
3.4 External Interfaces	3-181
2000 – Digital Inputs (DI)	3-182
2200 – Analog Input (AI)	3-183
2500 – USS on RS232, Receiving	3-184
2510 – USS on RS232, Transmitting	3-185
3.5 Internal Setpoint Source	3-186
3100 – Motor Potentiometer (MOP)	3-187
3200 – Fixed Frequency (FF) Direct Selection (P1016 = 1)	3-188
3210 – Fixed Frequency (FF) Binary Selection (P1016 = 2)	3-189
3300 – Fixed PID setpoint, Direct Selection (P2216 = 1)	3-190
3310 – Fixed PID setpoint, Binary Selection (P2216 = 2)	3-191
3400 – PID Motor Potentiometer (PID-MOP)	3-192
3.6 Technology Functions	3-193
4100 – Monitoring word 1 (r2197, bits 00 - 04)	3-194
4110 – Monitoring word 1 (r2197, bits 05 - 12)	3-195
4115 – Monitoring word 1 (r2197, bits 09 - 10)	3-196
4130 – Monitoring word 2 (r2198, bits 05 - 08)	3-197
4140 – Monitoring word 2 (r2198, bits 11 - 12)	3-198
4150 – Control word 1 (r0054)	3-199
4160 – Control word 2 (r0055)	3-200
4170 – Status word 1 (r0052)	3-201
4180 – Status word 2 (r0053)	3-202
4600 – Vdc_max control	3-203
3.7 Free Function Blocks	3-204
4800 – AND-, OR-, XOR- and NOT- Elements	3-205
4810 – FlipFlops	3-206

3.8 Setpoint Channel	3-207
5000 – Setpoint channel and Motor control	3-208
5100 – PID Controller	3-209
5200 – Additional Frequency Modifications (AFM)	3-210
5300 – Ramp Function Generator	3-211
3.9 V/f Control	3-212
6100 – Overview of V/f Control	3-213
3.10 Display values	3-214
8000 – Display values	3-215

3.2 Symbols in function diagrams

Function diagrams

0010 – Symbols in function diagrams

3-177

Explanation of symbols used in the function diagrams

Setting parameters

- Parameter text
- Minimum ... Maximum value [Unit]
- PNumber.C/D [0..2] (Default)
- Parameter number.Command/Drive data set [Number indexes] (Default)

Monitoring parameters

- Parameter text [Unit]
- PNumber.C/D [0..2]
- Parameter number.Command/Drive data set [Index range]

BICO parameters

- Binector input (Setting parameter)
 - Parameter text [Unit]
 - PNum.C/D (Default)
- Binector output (Monitoring parameter)
 - Parameter text
 - PNum
- Connector input (Setting parameter)
 - Parameter text
 - PNum.C/D [0..2] (Default)
- Connector output (Monitoring parameter)
 - Parameter text [Unit]
 - PNum [0..2]
- Connector/Binector output (Monitoring parameter)
 - Parameter text
 - PNum
 - PNum

The symbols are arranged in two columns. The left column contains: Summation (circle with plus), Multiplication (square with X), Division (square with /), Switch (square with switch symbol), Selection switch (1 out of 4) (square with switch and 00, 01, 10, 11), ON delay (square with T and 0), OFF delay (square with T and 1), AND gate (square with &), OR gate (square with ≥1), XOR gate (square with =1), NOT gate (square with 1 and circle), NOT gate (square with triangle and circle), A/D converter (square with A/D), and D/A converter (square with D/A).

The right column contains: Filter element (graph of a low-pass filter), Gain element (graph of a step function), Integrator (graph of a ramp), PI controller (graph with Kp and Tn), Differentiator (graph of a step function), Limitation (graph of a ramp with limits), Limitation (graph of a ramp with limits), Characteristic (graph of a hysteresis loop), and Hysteresis (graph of a hysteresis loop).

Sheet 2300 Details refer to sheet 2300

1 Reference signal between function diagrams

1	2	3	4	5	6	7	8
0010_Symbols.vsd						Function diagram	
05.10.2016 V3.7						SINAMICS G110D	

Symbols in function diagrams

Fig. 3-1 0010 – Symbols in function diagrams

3.3 Overview

Function plans

1100 – General Overview	3-179
1200 – Connection of External and Internal Setpoints	3-180

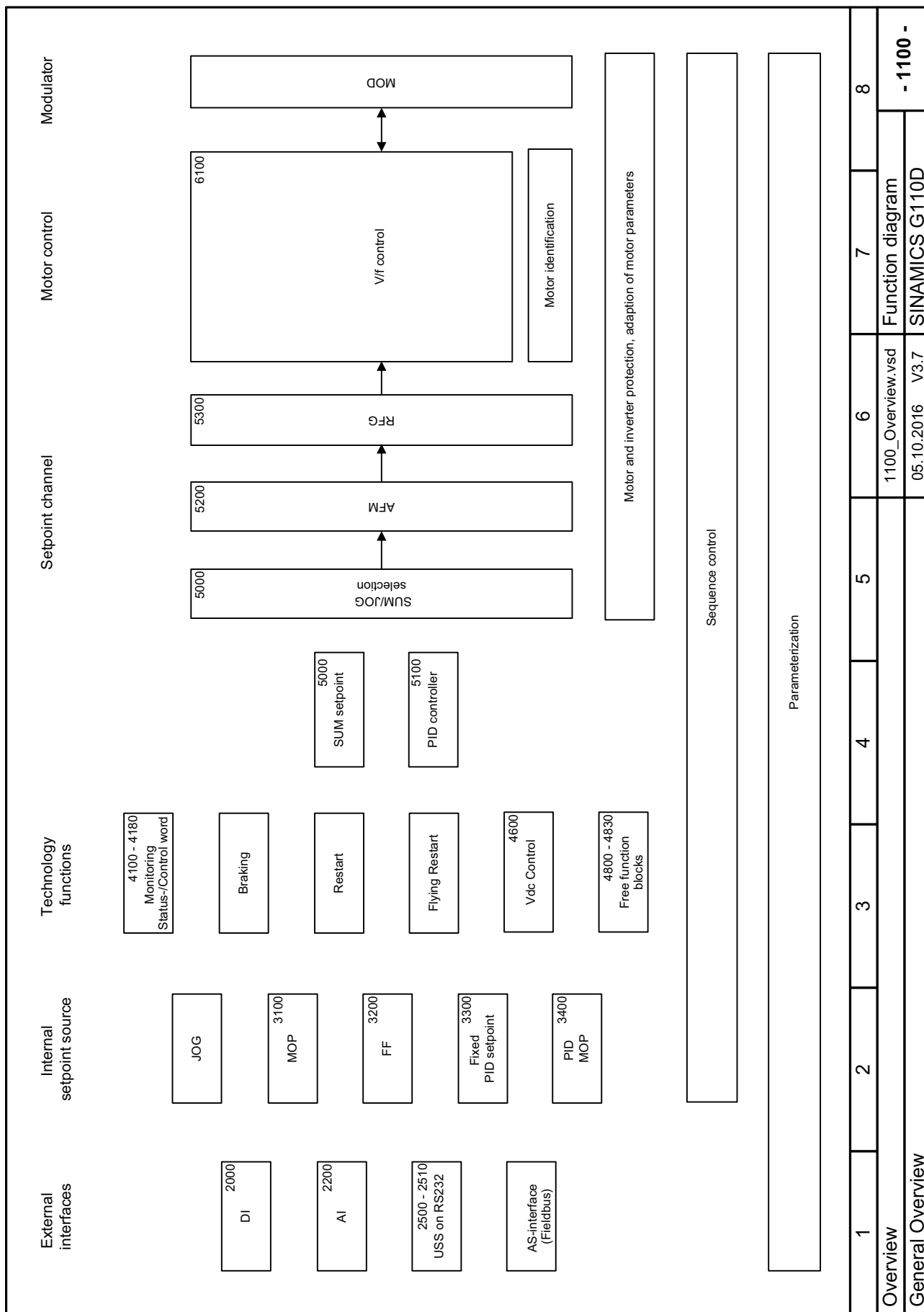

Fig. 3-2 1100 – General Overview

3.4 External Interfaces

Function diagrams

2000 – Digital Inputs (DI)	3-182
2200 – Analog Input (AI)	3-183
2500 – USS on RS232, Receiving	3-184
2510 – USS on RS232, Transmitting	3-185

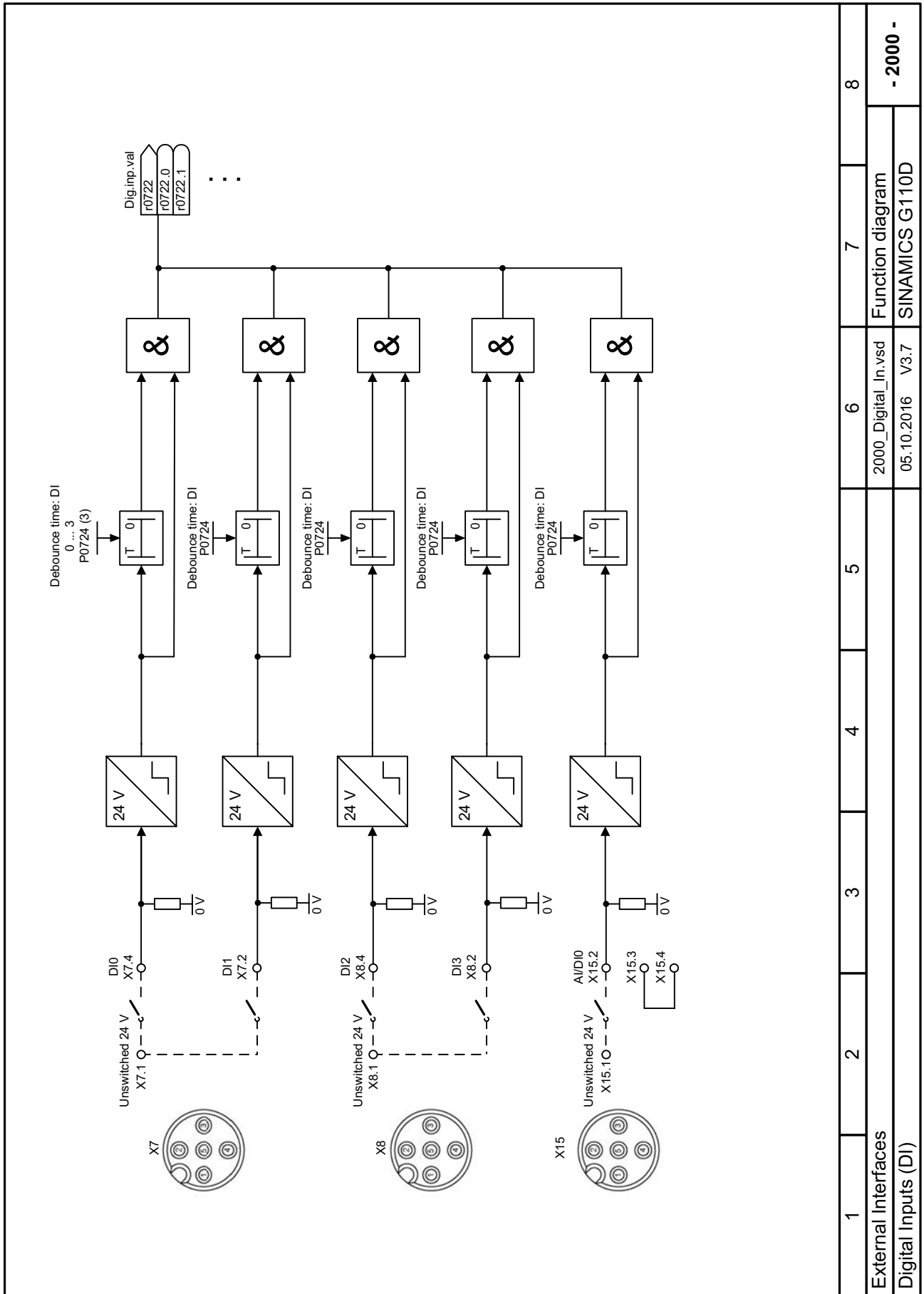

Fig. 3-4 2000 – Digital Inputs (DI)

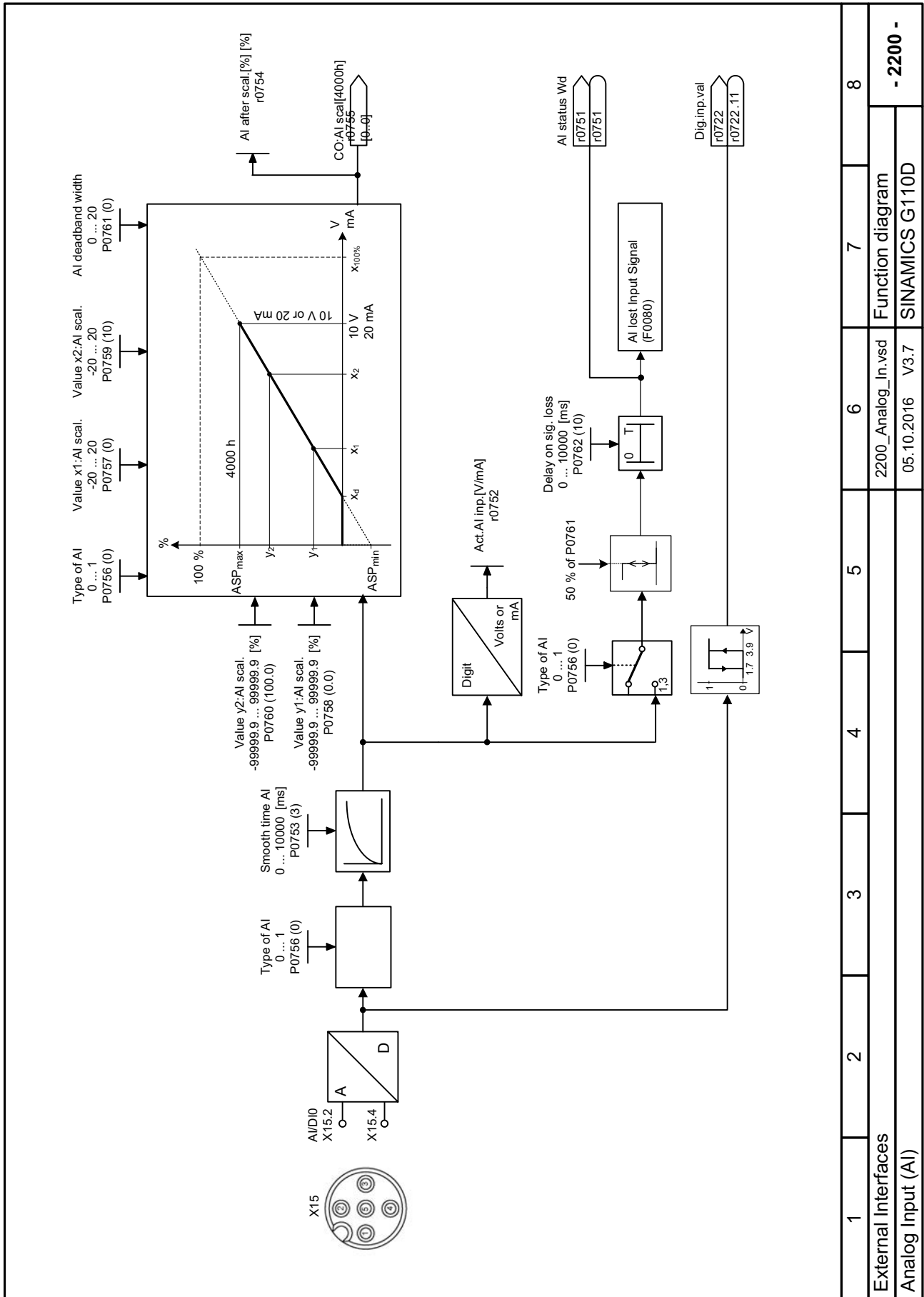

Fig. 3-5 2200 – Analog Input (AI)

1	2	3	4	5	6	7	8	
External Interfaces								Function diagram
Analog Input (AI)								SINAMICS G110D
2200_Analog_In.vsd						- 2200 -		
05.10.2016 V3.7								

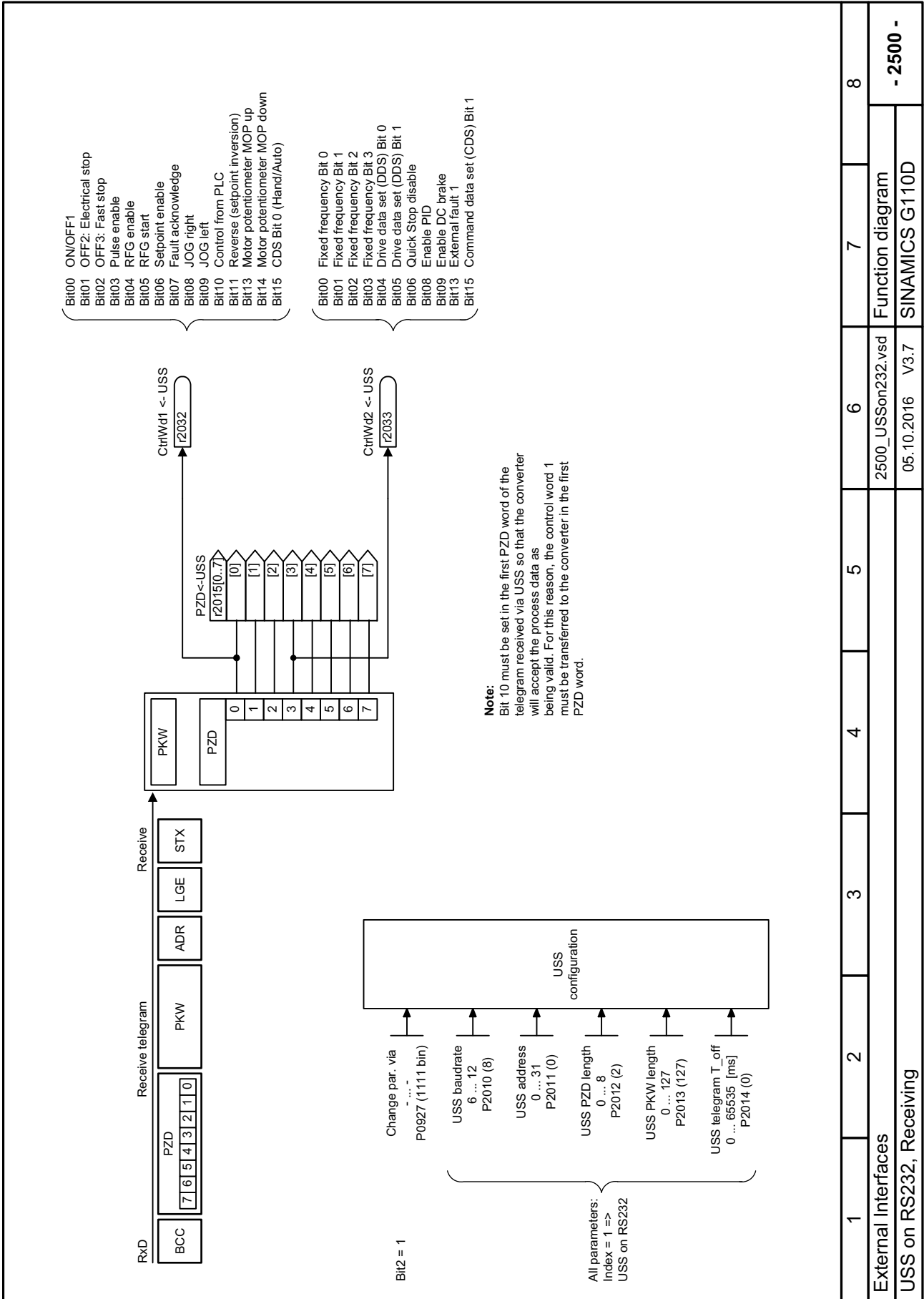

Fig. 3-6 2500 – USS on RS232, Receiving

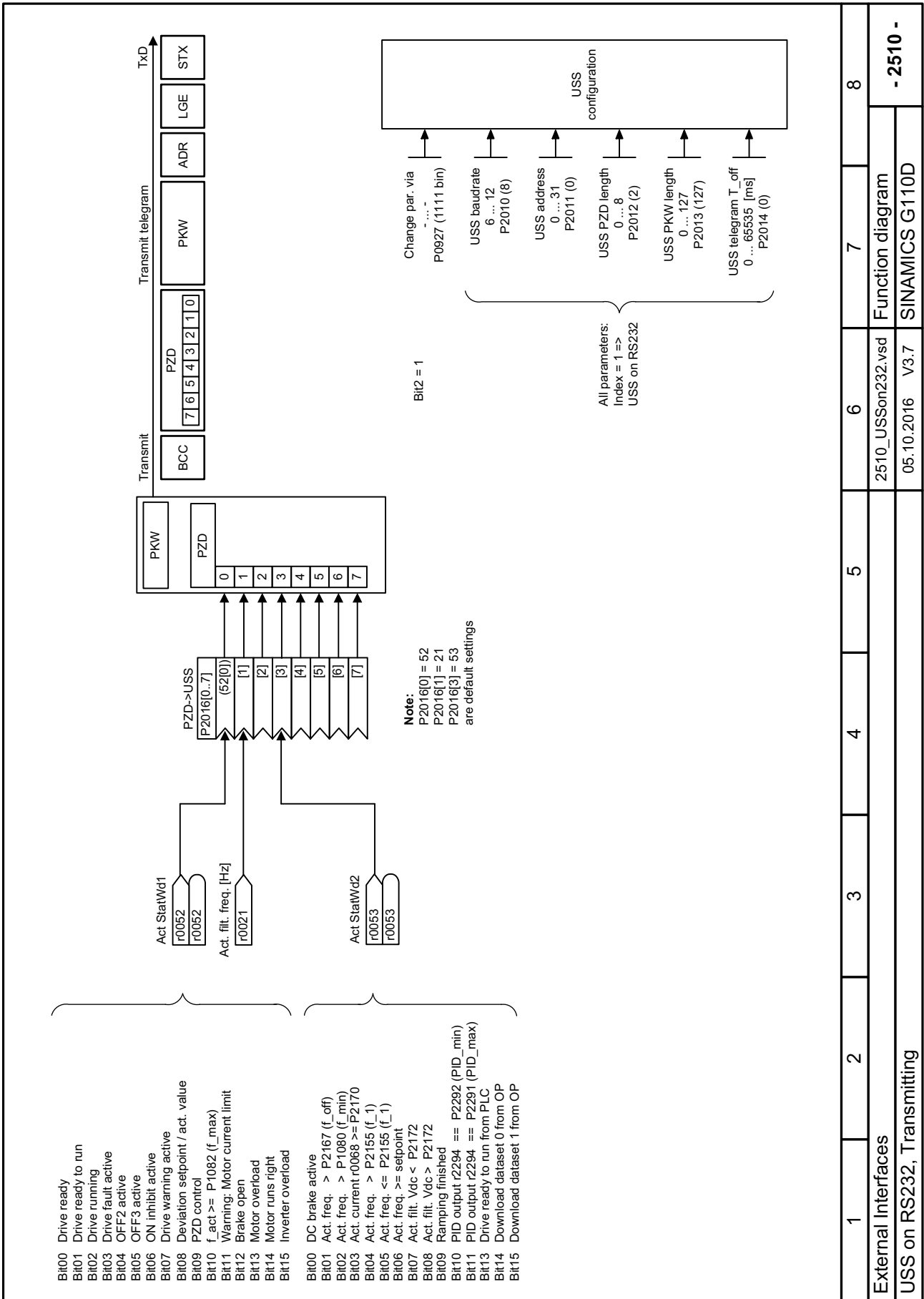

Fig. 3-7 2510 – USS on RS232, Transmitting

3.5 Internal Setpoint Source

Function diagrams

3100 – Motor Potentiometer (MOP)	3-187
3200 – Fixed Frequency (FF) Direct Selection (P1016 = 1)	3-188
3210 – Fixed Frequency (FF) Binary Selection (P1016 = 2)	3-189
3300 – Fixed PID setpoint, Direct Selection (P2216 = 1)	3-190
3310 – Fixed PID setpoint, Binary Selection (P2216 = 2)	3-191
3400 – PID Motor Potentiometer (PID-MOP)	3-192

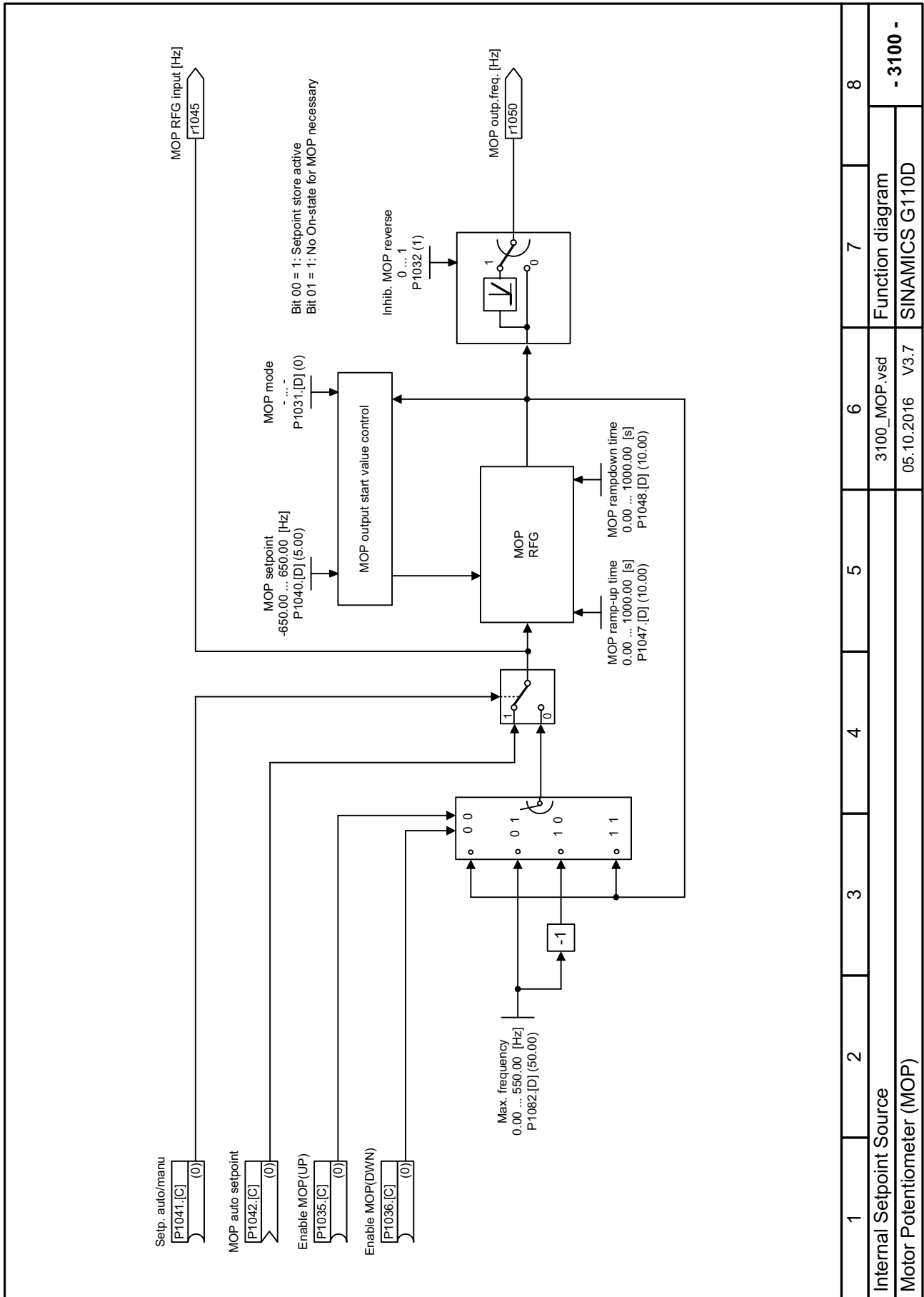

Fig. 3-8 3100 – Motor Potentiometer (MOP)

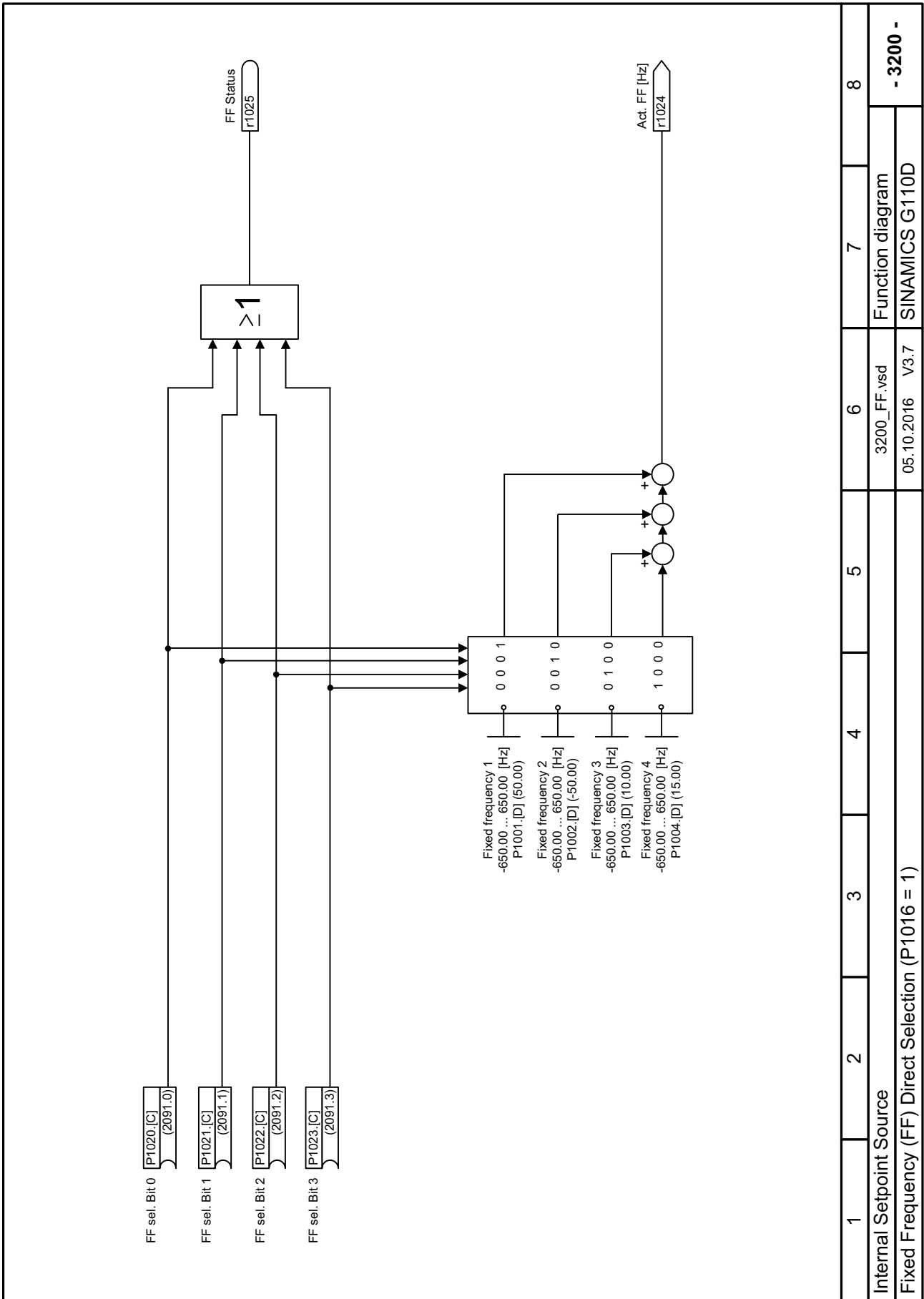

Fig. 3-9 3200 – Fixed Frequency (FF) Direct Selection (P1016 = 1)

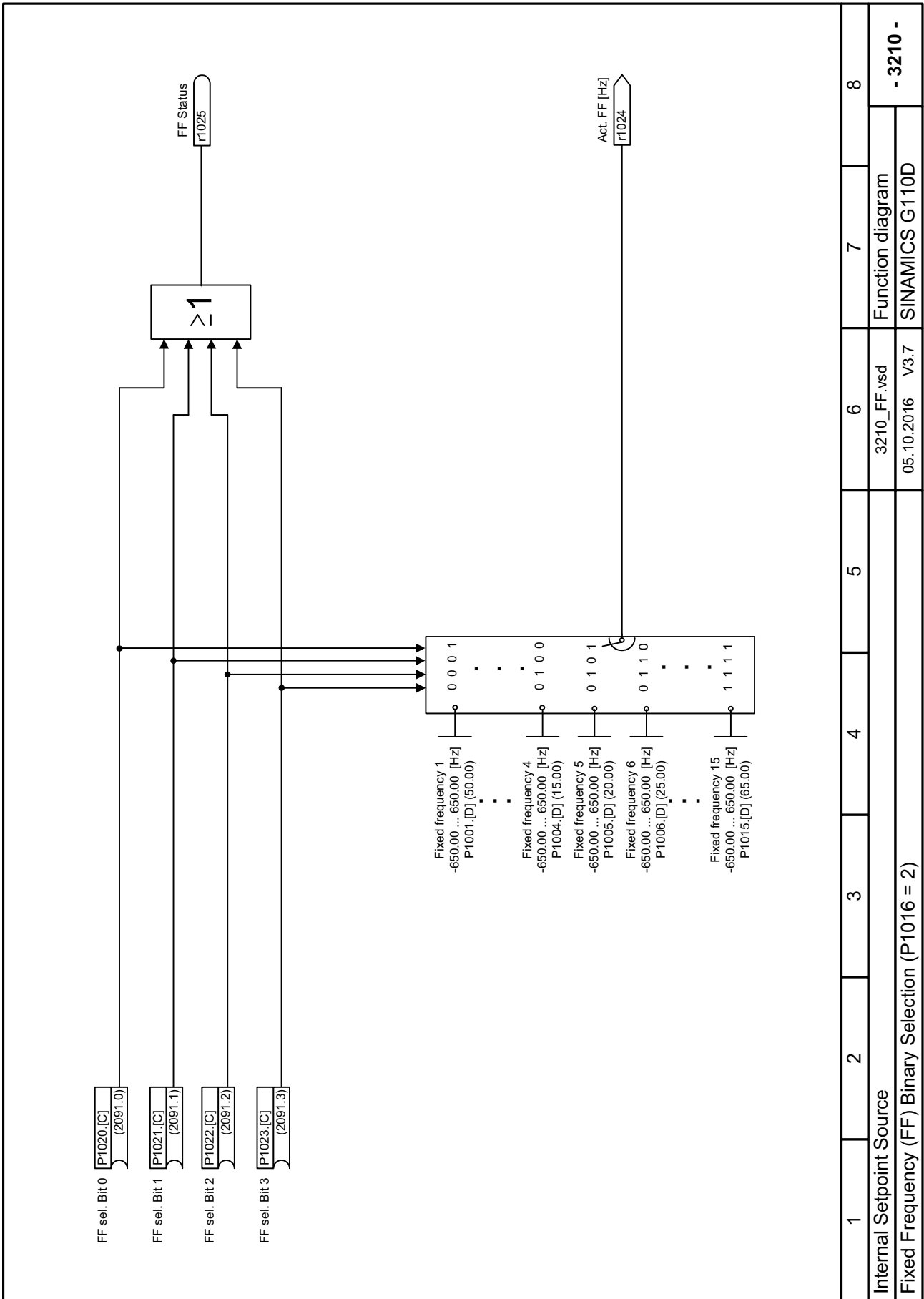

Fig. 3-10 3210 – Fixed Frequency (FF) Binary Selection (P1016 = 2)

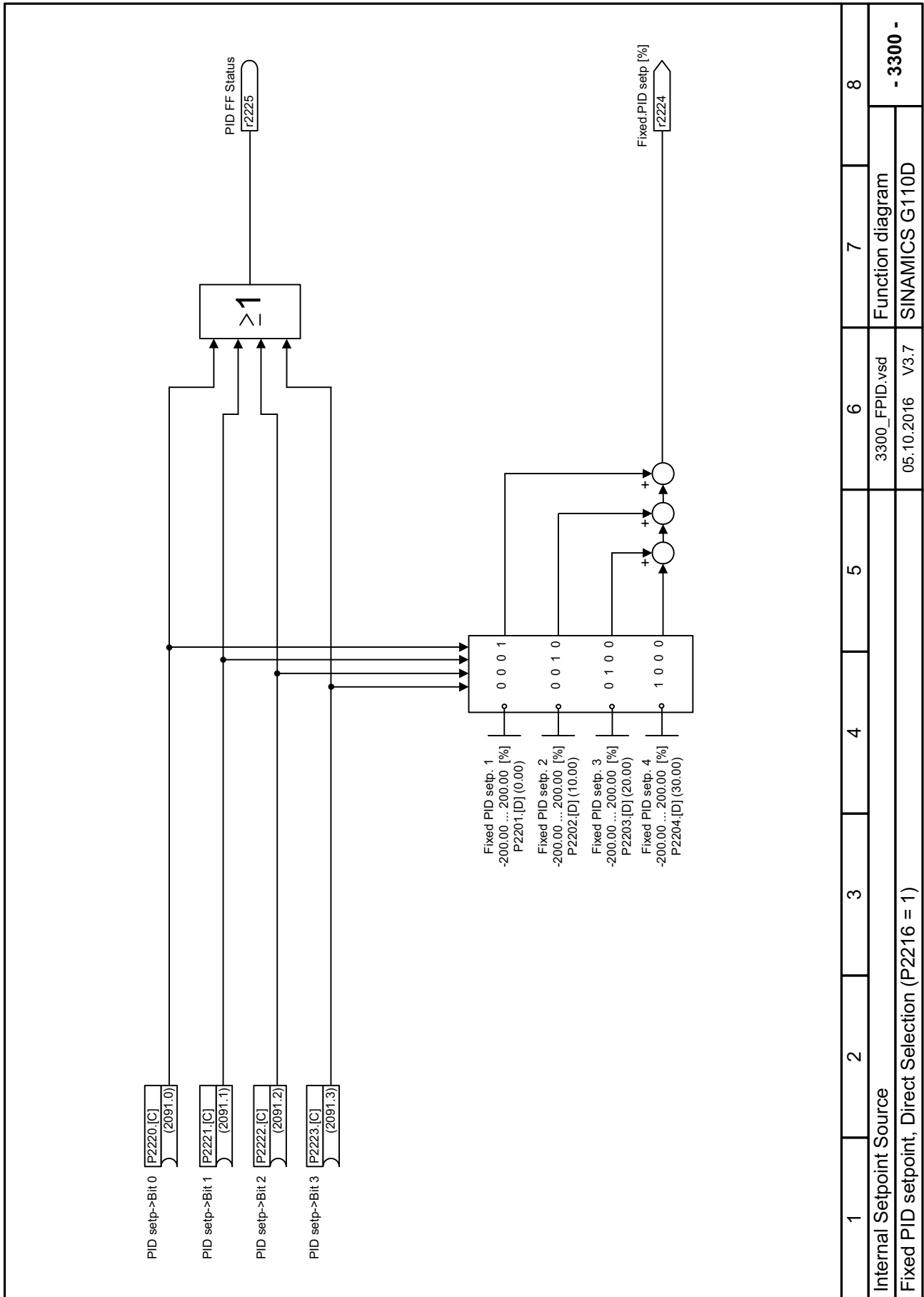

Fig. 3-11 3300 – Fixed PID setpoint, Direct Selection (P2216 = 1)

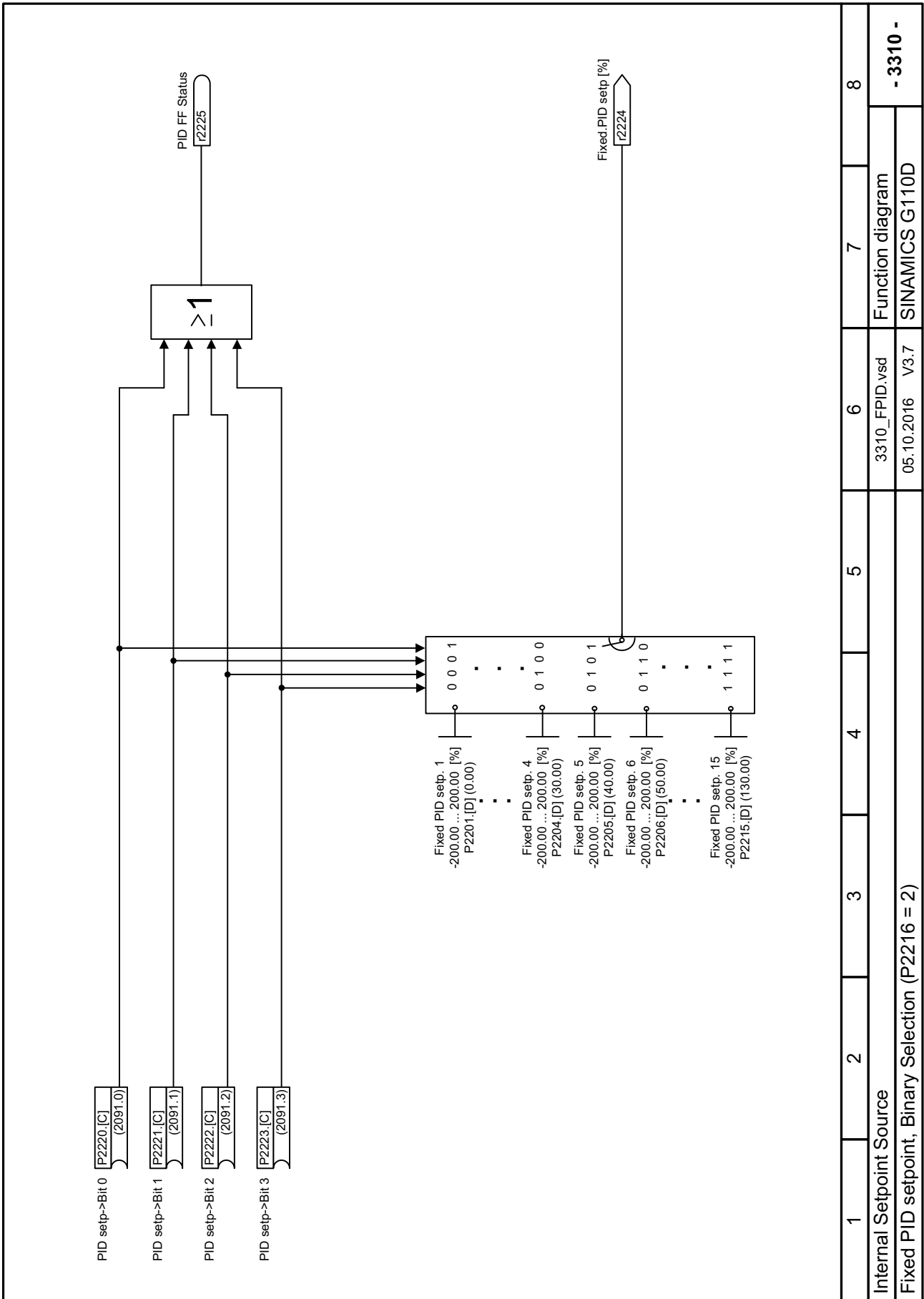

Fig. 3-12 3310 – Fixed PID setpoint, Binary Selection (P2216 = 2)

1	2	3	4	5	6	7	8
Internal Setpoint Source						Function diagram	
Fixed PID setpoint, Binary Selection (P2216 = 2)						- 3310 -	
3310_FPID.vsd						SINAMICS G110D	
05.10.2016 V3.7							

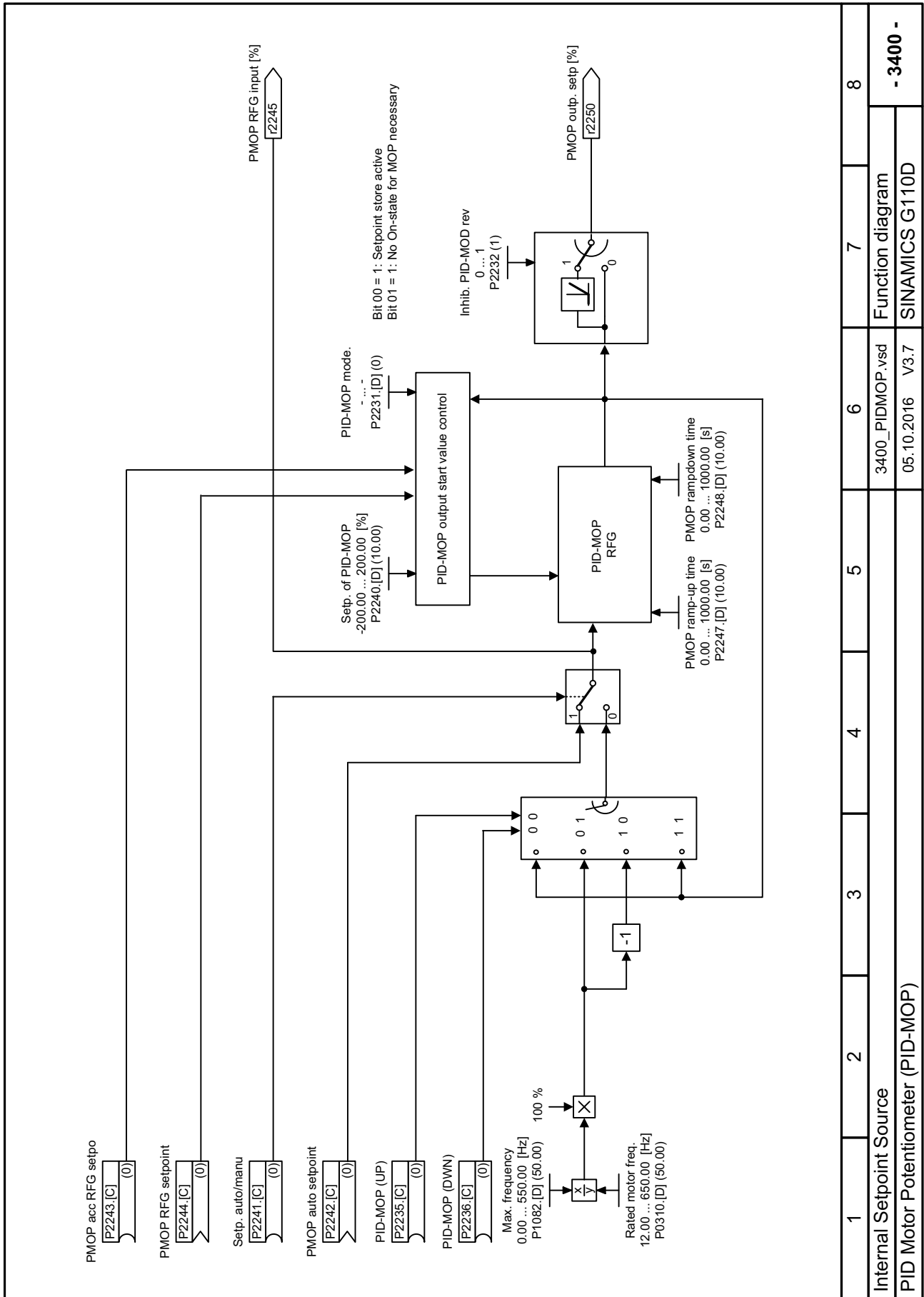

Fig. 3-13 3400 – PID Motor Potentiometer (PID-MOP)

1	2	3	4	5	6	7	8
Internal Setpoint Source							
PID Motor Potentiometer (PID-MOP)							
3400_PIDMOP.vsd						Function diagram	
05.10.2016 V3.7						- 3400 -	
SINAMICS G110D							

3.6 Technology Functions

Function diagrams

4100 – Monitoring word 1 (r2197, bits 00 - 04)	3-194
4110 – Monitoring word 1 (r2197, bits 05 - 12)	3-195
4115 – Monitoring word 1 (r2197, bits 09 - 10)	3-196
4130 – Monitoring word 2 (r2198, bits 05 - 08)	3-197
4140 – Monitoring word 2 (r2198, bits 11 - 12)	3-198
4150 – Control word 1 (r0054)	3-199
4160 – Control word 2 (r0055)	3-200
4170 – Status word 1 (r0052)	3-201
4180 – Status word 2 (r0053)	3-202
4600 – Vdc_max control	3-203

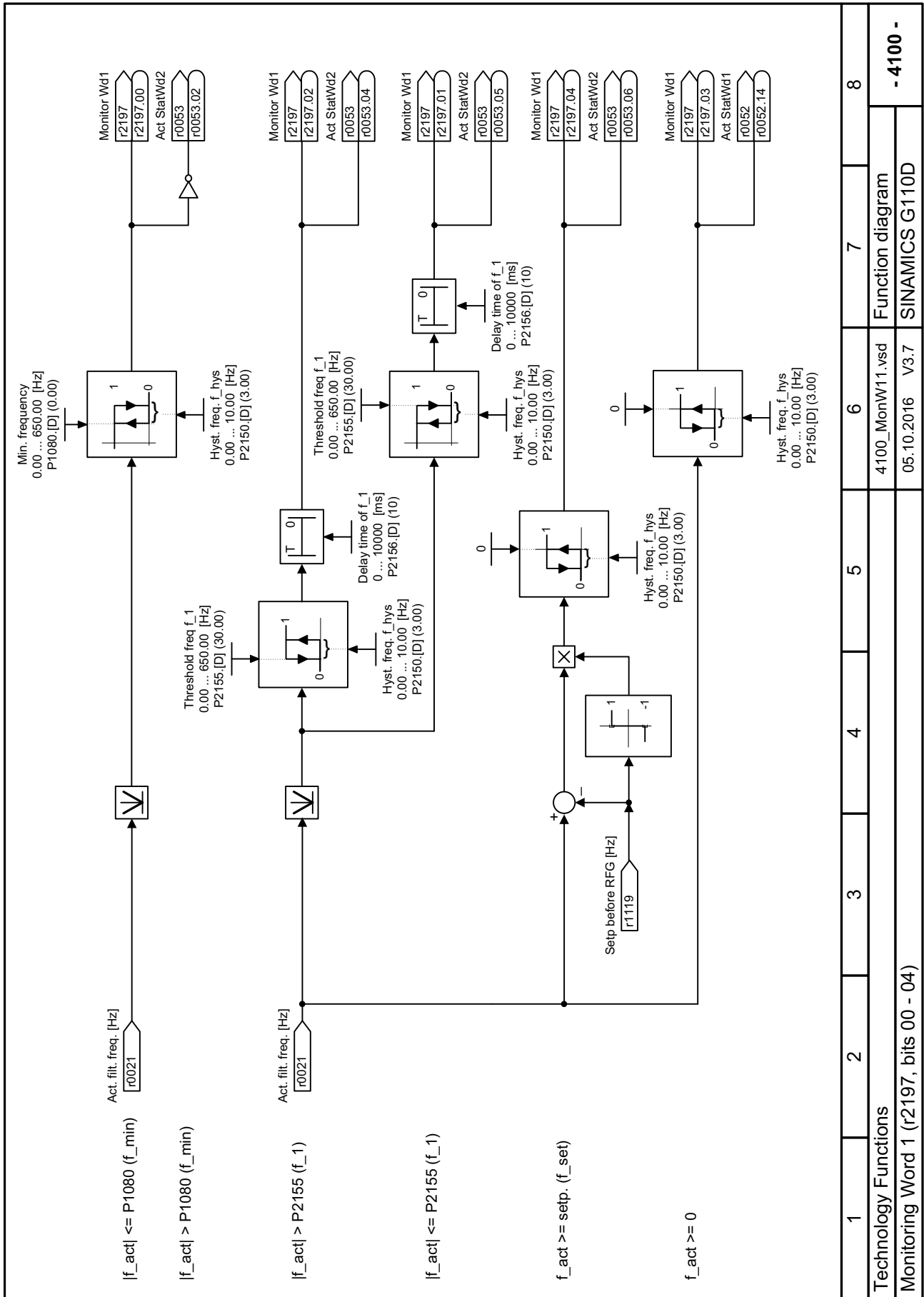

Fig. 3-14 4100 – Monitoring word 1 (r2197, bits 00 - 04)

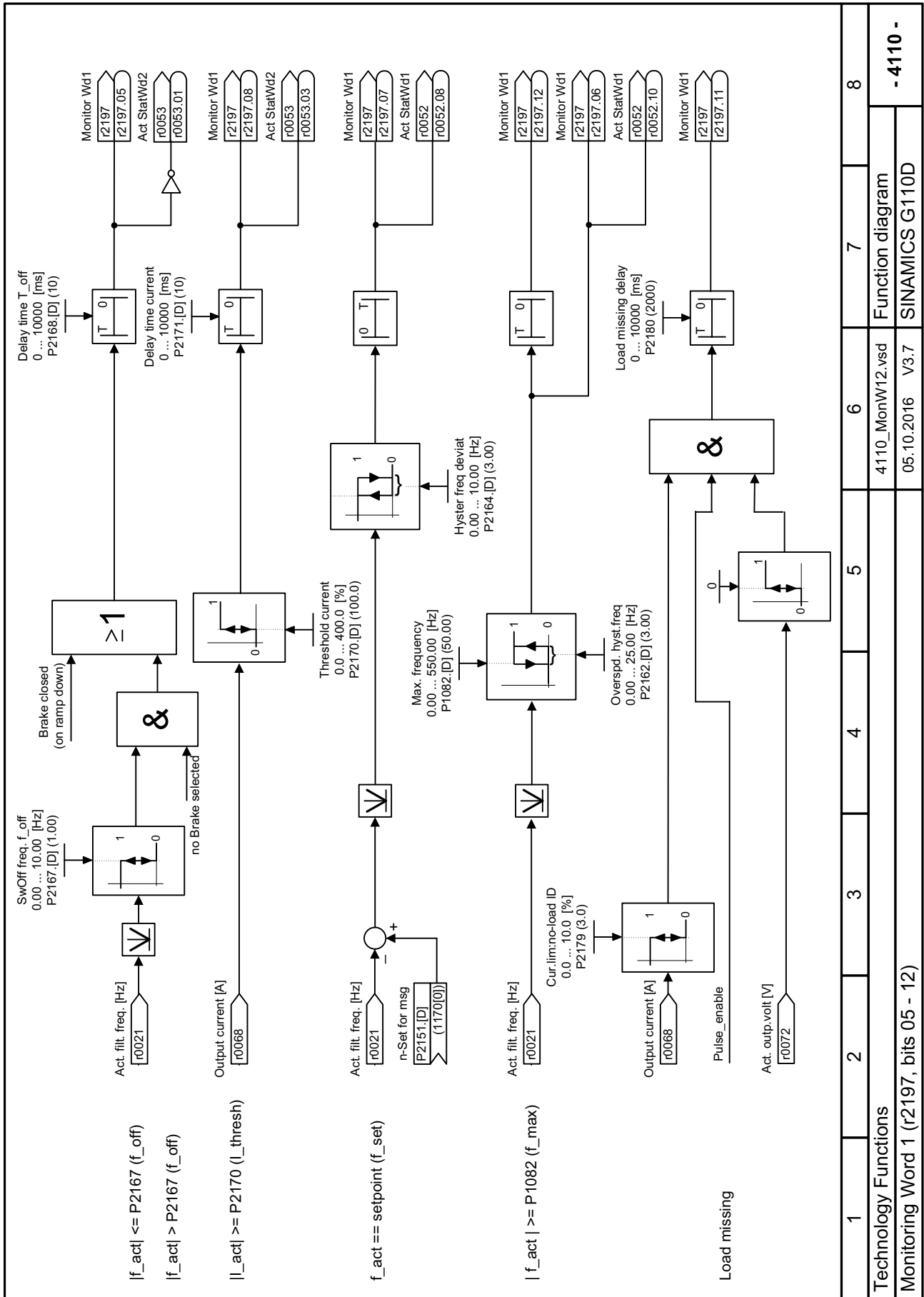

Fig. 3-15 4110 – Monitoring word 1 (r2197, bits 05 - 12)

1	2	3	4	5	6	7	8
Technology Functions							
4110_MonW12.vsd							
Function diagram							
Monitoring Word 1 (r2197, bits 05 - 12)							
05.10.2016 V3.7							
SINAMICS G110D							
- 4110 -							

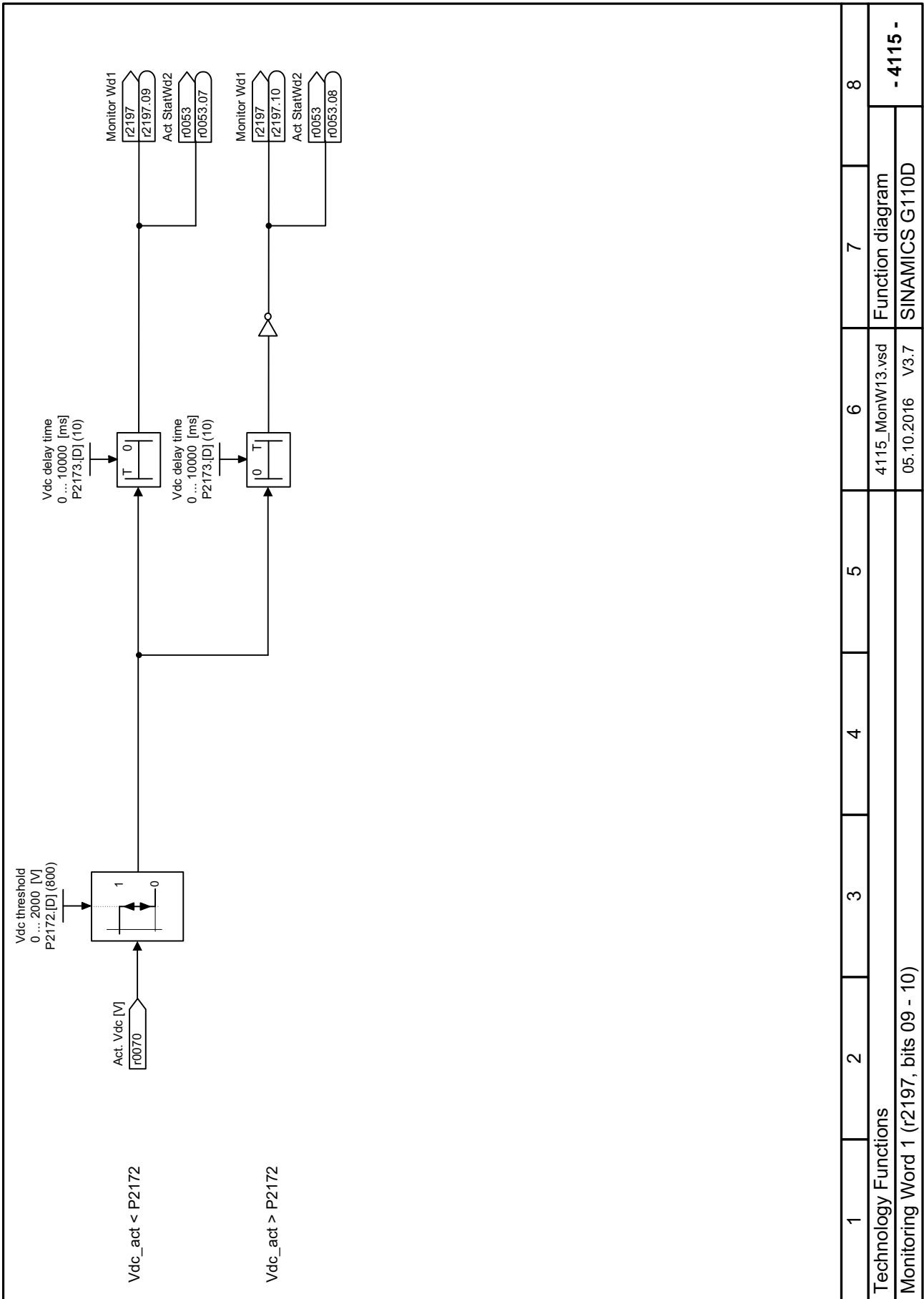

Fig. 3-16 4115 – Monitoring word 1 (r2197, bits 09 - 10)

1	2	3	4	5	6	7	8
Technology Functions							
Monitoring Word 1 (r2197, bits 09 - 10)							
4115_MonW13.vsd						Function diagram	
05.10.2016 V3.7						SINAMICS G110D	
- 4115 -							

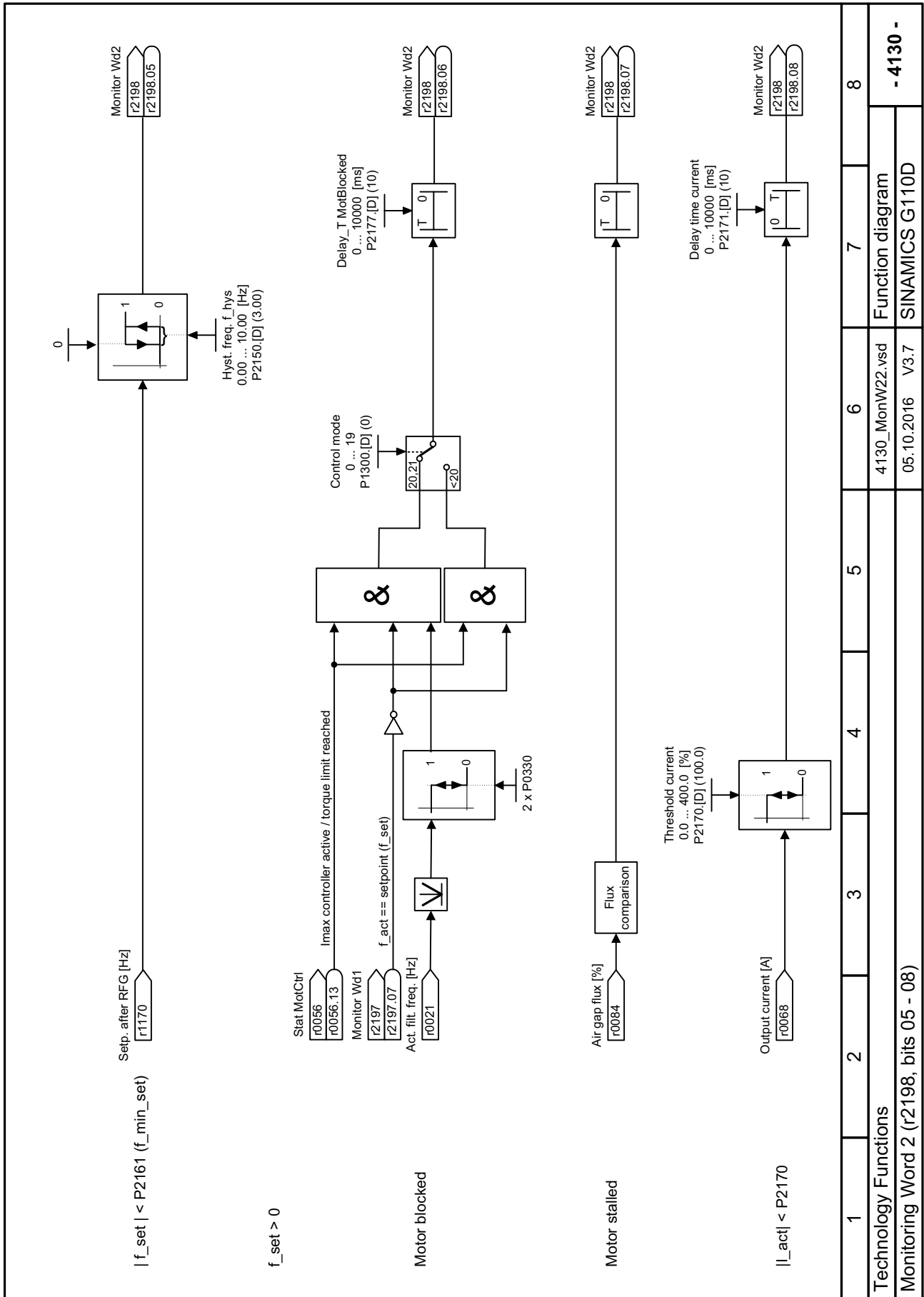

Fig. 3-17 4130 – Monitoring word 2 (r2198, bits 05 - 08)

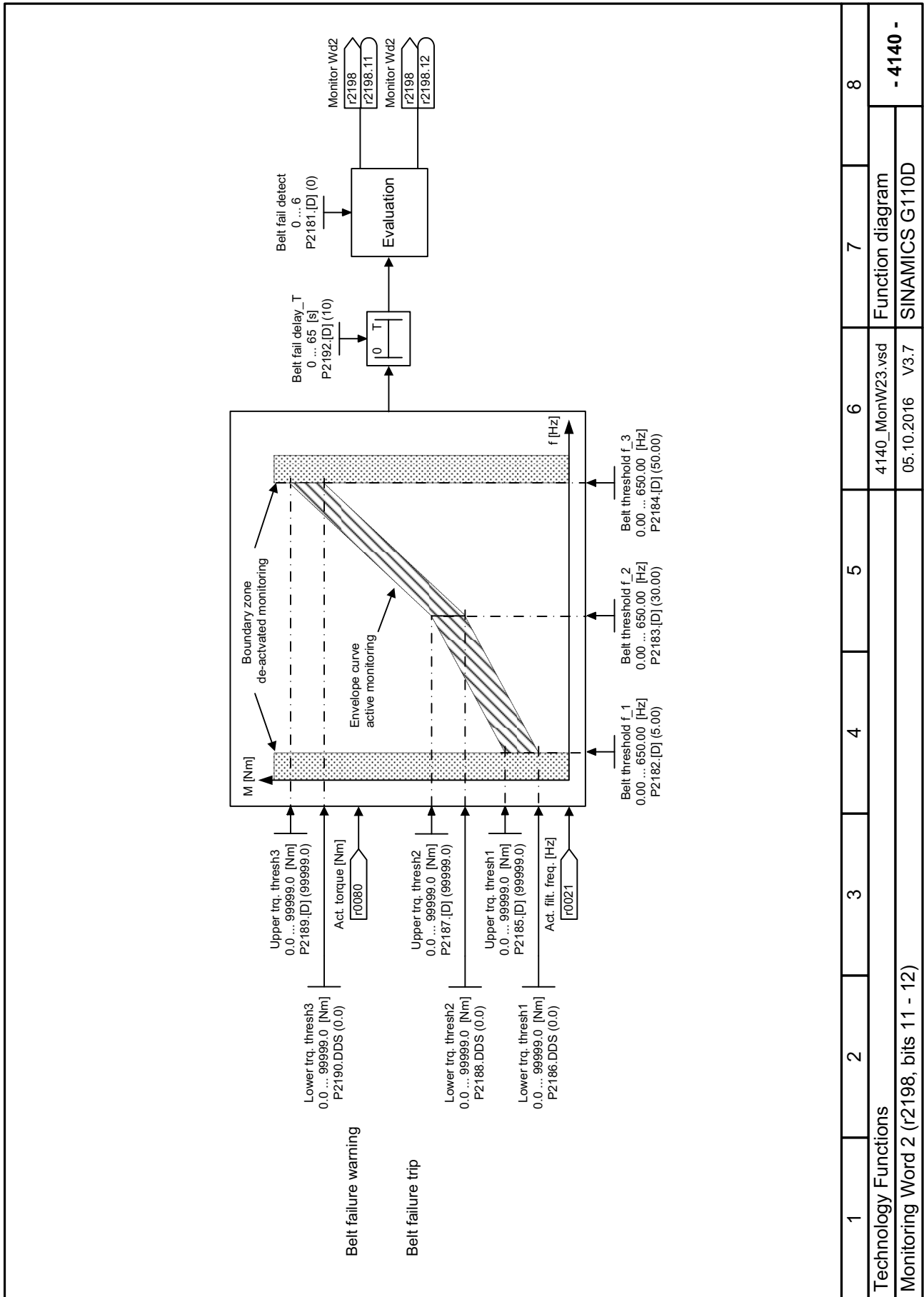

Fig. 3-18 4140 – Monitoring word 2 (r2198, bits 11 - 12)

1	2	3	4	5	6	7	8
Technology Functions							
Function diagram							
4140_MonW23.vsd							
Monitoring Word 2 (r2198, bits 11 - 12)							
05.10.2016 V3.7							
SINAMICS G110D							
- 4140 -							

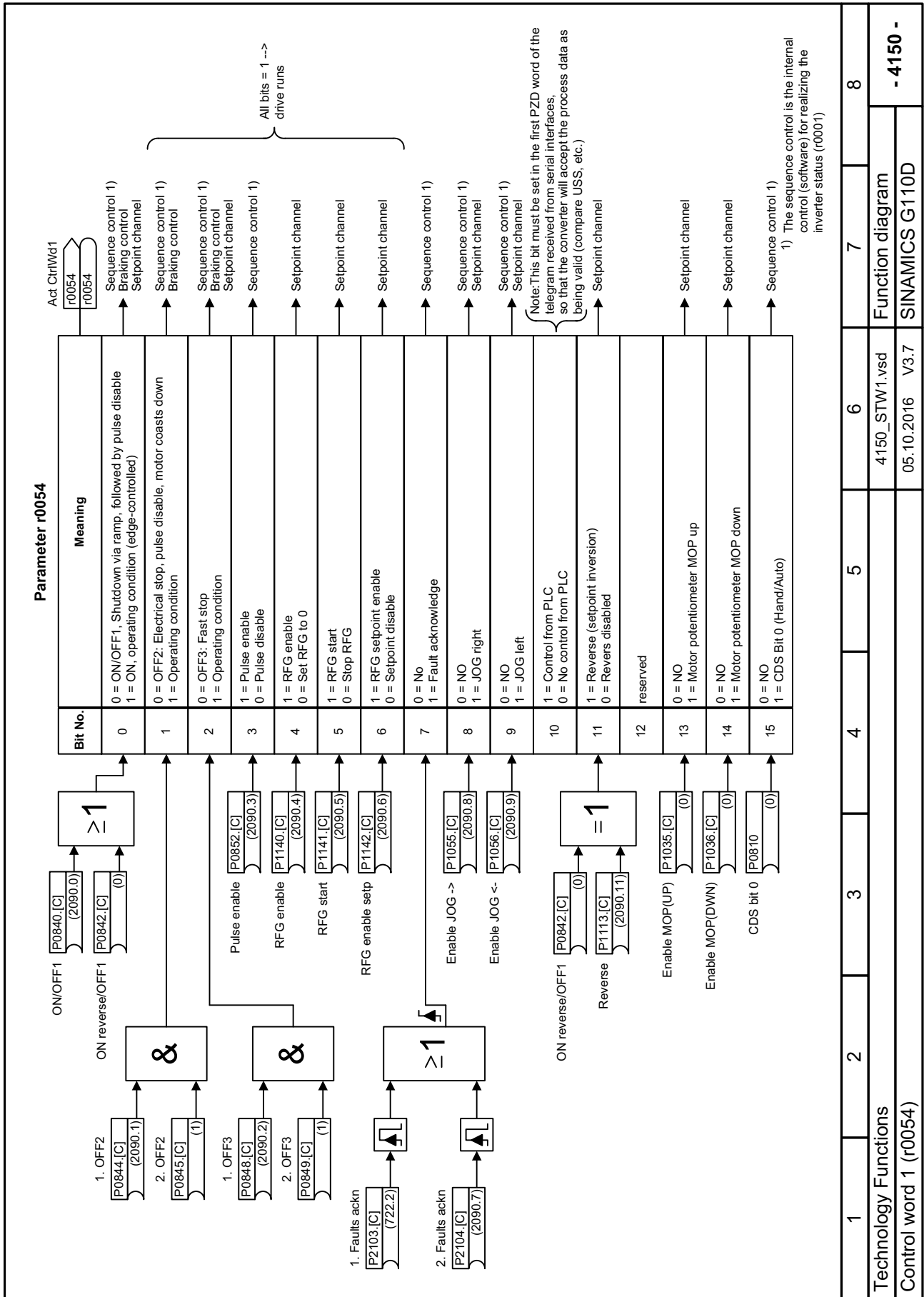

Fig. 3-19 4150 – Control word 1 (r0054)

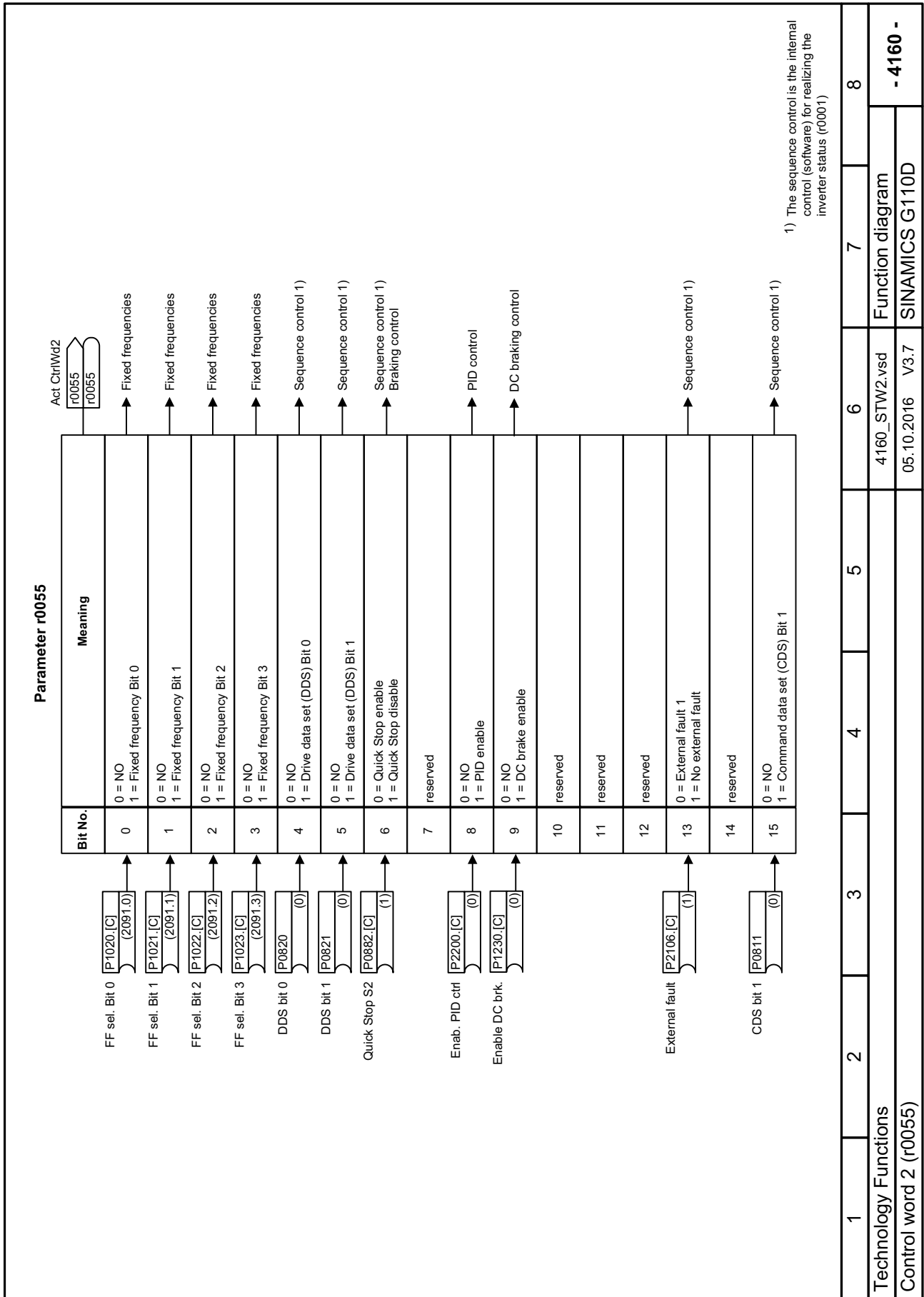

Fig. 3-20 4160 – Control word 2 (r0055)

Parameter r0053		Act StatWd2	
Bit No.	Meaning	r0053	r0053
0	1 = DC brake active 0 = DC brake not active		
1	1 = f_act > P2167 (f_off)		
2	1 = f_act > P1080 (f_min)		
3	1 = Act. current r0068 >= P2170		
4	1 = f_act > P2155 (f_1)		
5	1 = f_act <= P2155 (f_1)		
6	1 = f_act >= setpoint		
7	1 = Act. unfit. Vdc r0070 < P2172		
8	1 = Act. unfit. Vdc r0070 > P2172		
9	1 = Ramping finished		
10	1 = PID output r2294 == P2292 (PID_min)		
11	1 = PID output r2294 == P2291 (PID_max)		
12	reserved		
13	1 = Drive ready to run from PLC		
14	Download data set 0 from OP		
15	Download data set 1 from OP		

1) The sequence control is the internal control (software) for realizing the inverter status (r0001)

1	2	3	4	5	6	7	8
Technology Functions						Function diagram	
Status word 2 (r0053)						SINAMICS G110D	
4180_ZSW2.vsd						- 4180 -	
05.10.2016 V3.7							

Fig. 3-22 4180 – Status word 2 (r0053)

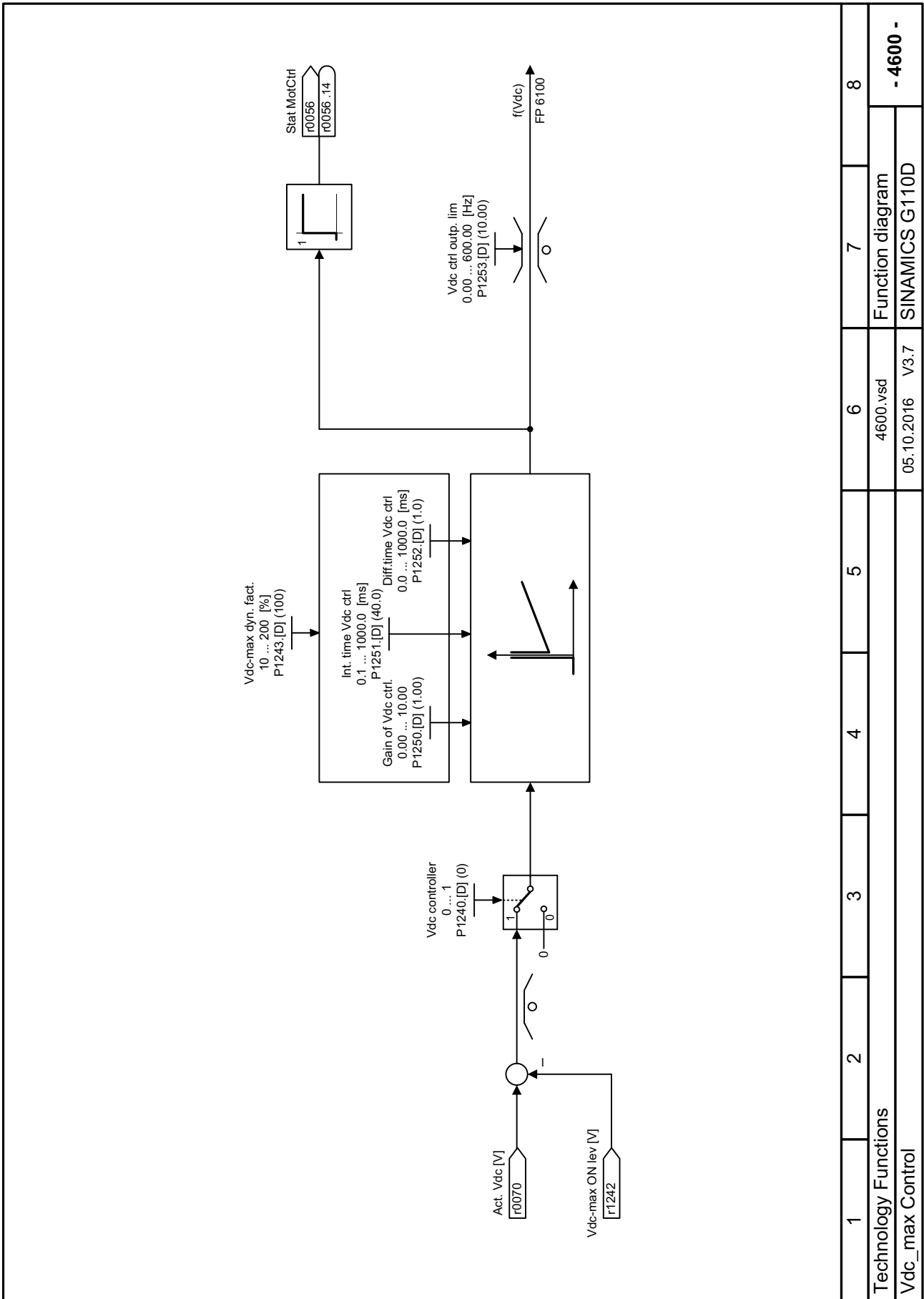

Fig. 3-23 4600 – Vdc_max control

1	2	3	4	5	6	7	8
Technology Functions							
Vdc_max Control							
4600.vsd						Function diagram	
05.10.2016 V3.7						SINAMICS G110D	
- 4600 -							

3.7 Free Function Blocks

Function diagrams

4800 – AND-, OR-, XOR- and NOT- Elements	3-205
4810 – FlipFlops	3-206

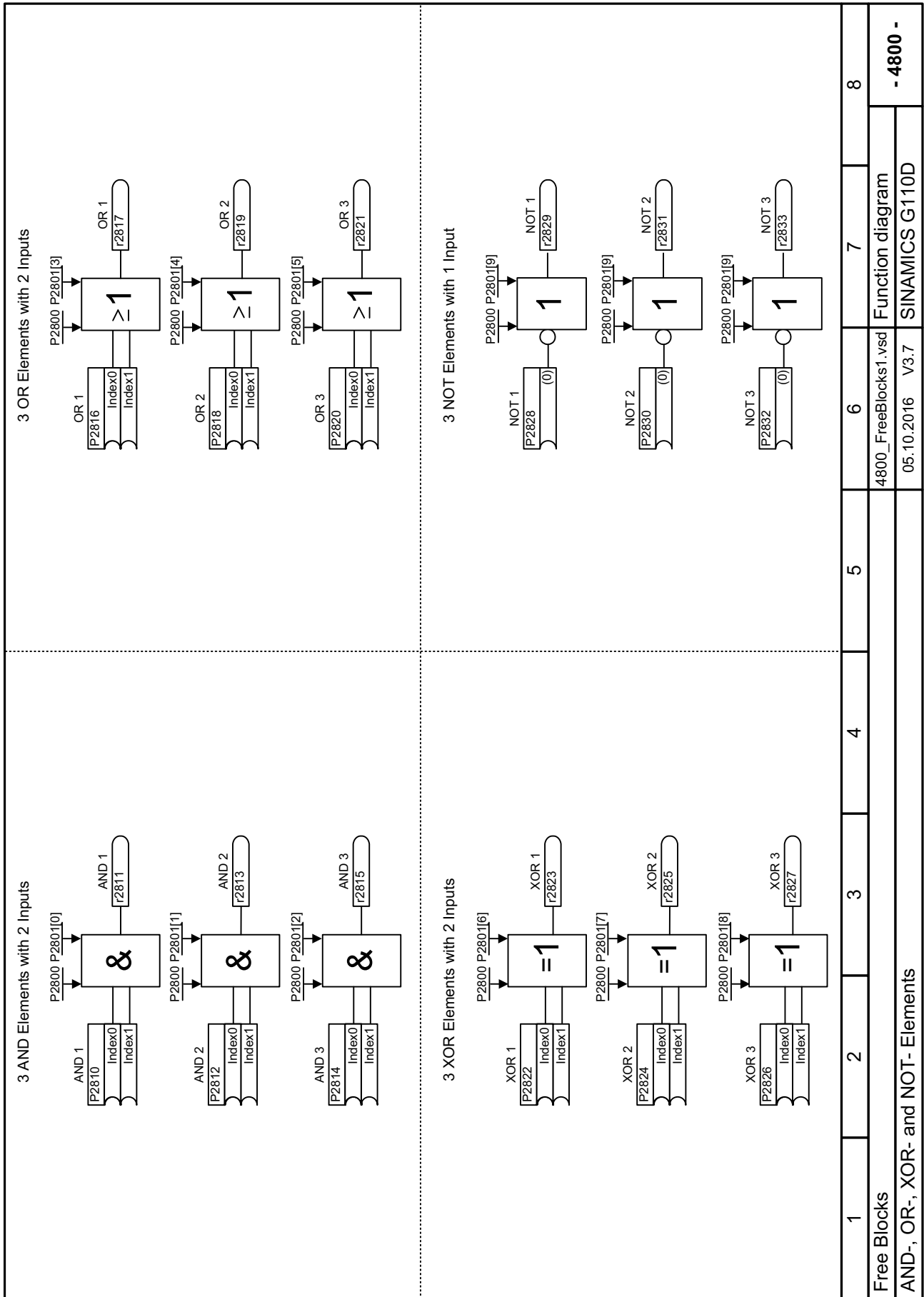

Fig. 3-24 4800 – AND-, OR-, XOR- and NOT- Elements

1	2	3	4	5	6	7	8
Free Blocks							
4800_FreeBlocks1.vsd Function diagram							
AND-, OR-, XOR- and NOT- Elements							
05.10.2016 V3.7 SINAMICS G110D - 4800 -							

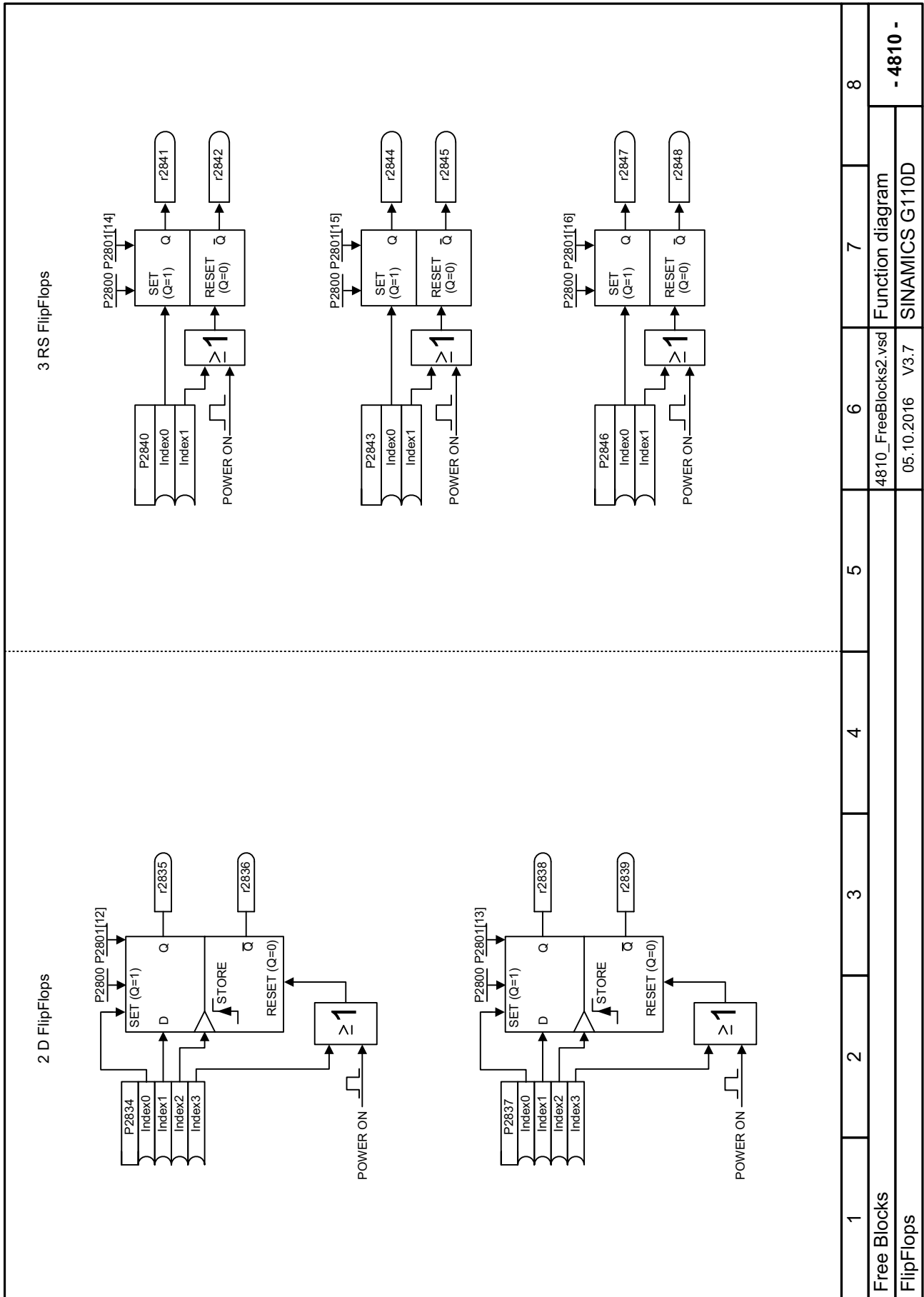
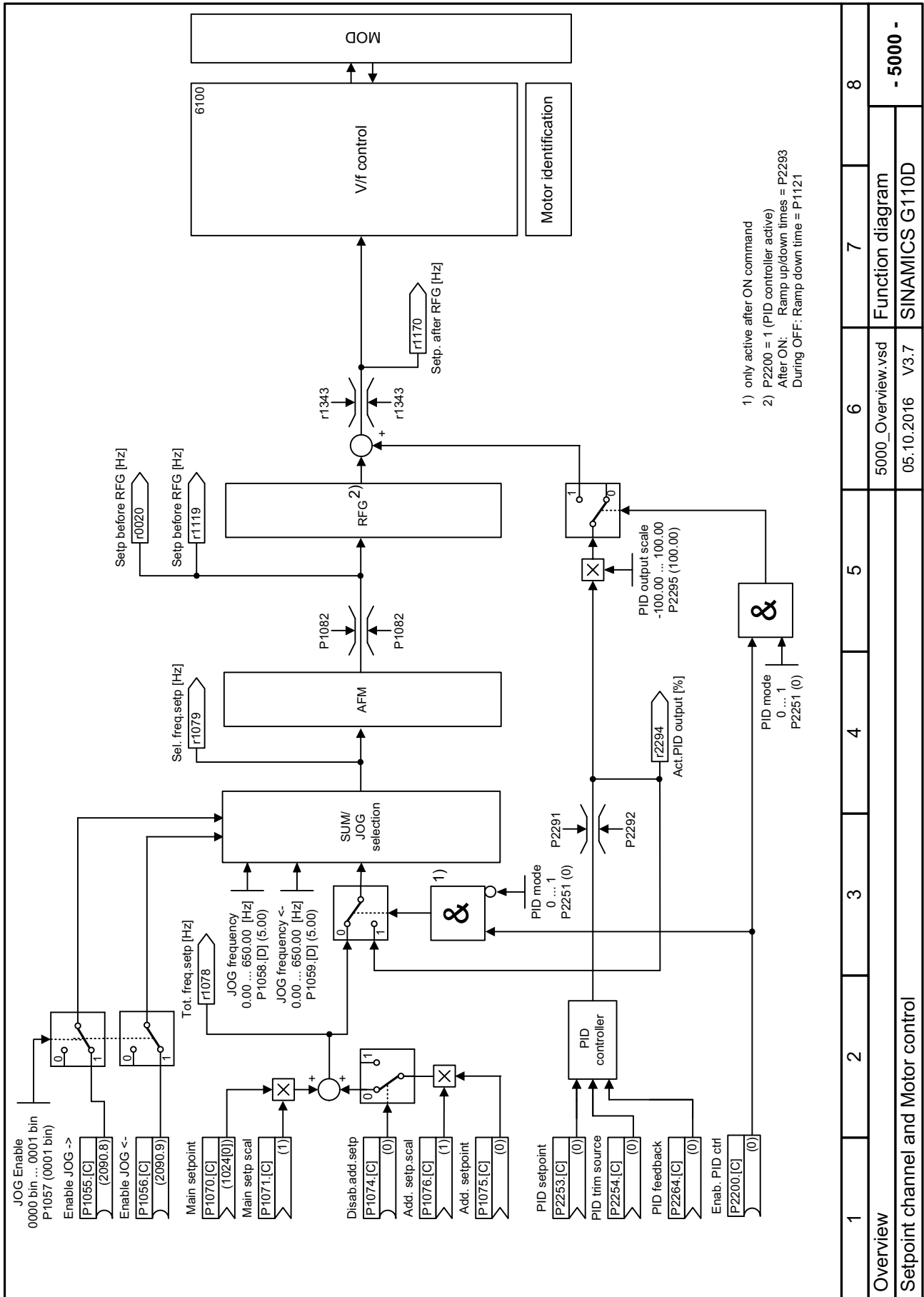

Fig. 3-25 4810 – FlipFlops

3.8 Setpoint Channel

Function diagrams

5000 – Setpoint channel and Motor control	3-208
5100 – PID Controller	3-209
5200 – Additional Frequency Modifications (AFM)	3-210
5300 – Ramp Function Generator	3-211



1) only active after ON command
 2) P2200 = 1 (PID controller active)
 After ON: Ramp up/down times = P2293
 During OFF: Ramp down time = P1121

Fig. 3-26 5000 – Setpoint channel and Motor control

1	2	3	4	5	6	7	8
Overview							
Setpoint channel and Motor control							
5000_Overview.vsd						Function diagram	
05.10.2016						V3.7	
- 5000 -							

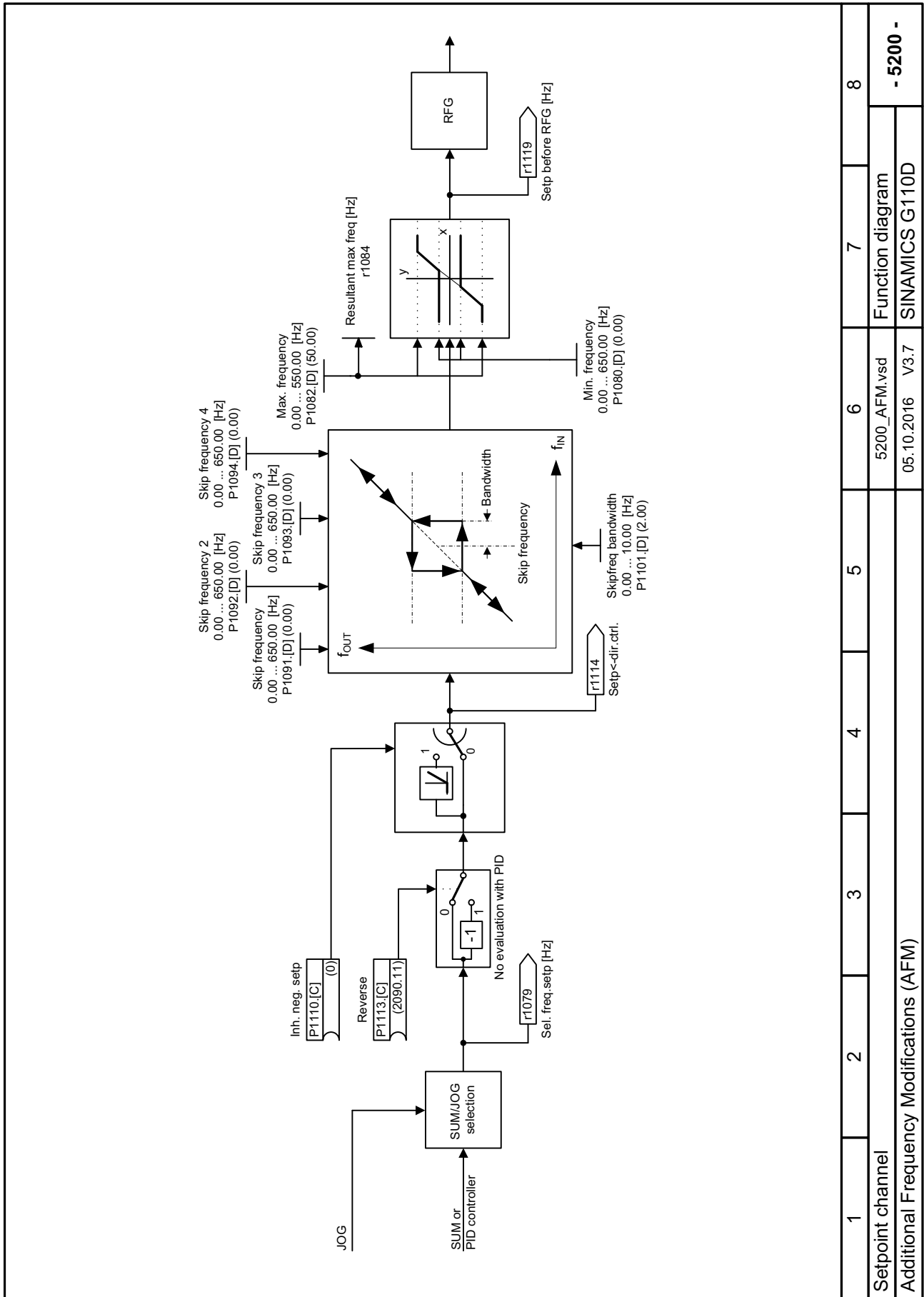
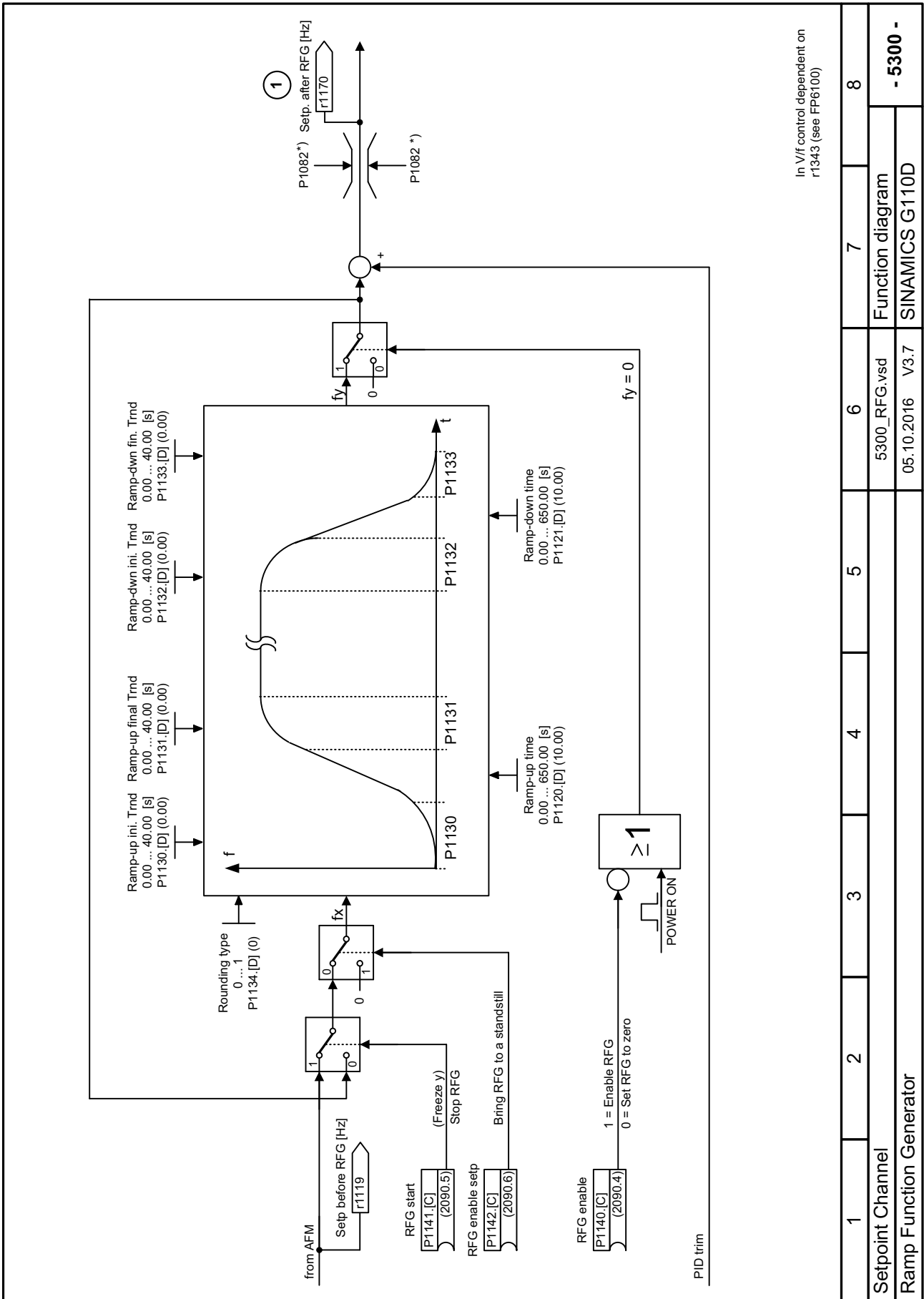

Fig. 3-28 5200 – Additional Frequency Modifications (AFM)

1	2	3	4	5	6	7	8
Setpoint channel							
Additional Frequency Modifications (AFM)							
				5200_AFM.vsd	Function diagram		- 5200 -
				05.10.2016	V3.7	SINAMICS G110D	



In V/f control dependent on r1343 (see FP6100)

Fig. 3-29 5300 – Ramp Function Generator

1	2	3	4	5	6	7	8
Setpoint Channel						Function diagram	
Ramp Function Generator						SINAMICS G110D	
5300_RFG.vsd						- 5300 -	
05.10.2016 V3.7							

3.9 V/f Control

Function diagrams

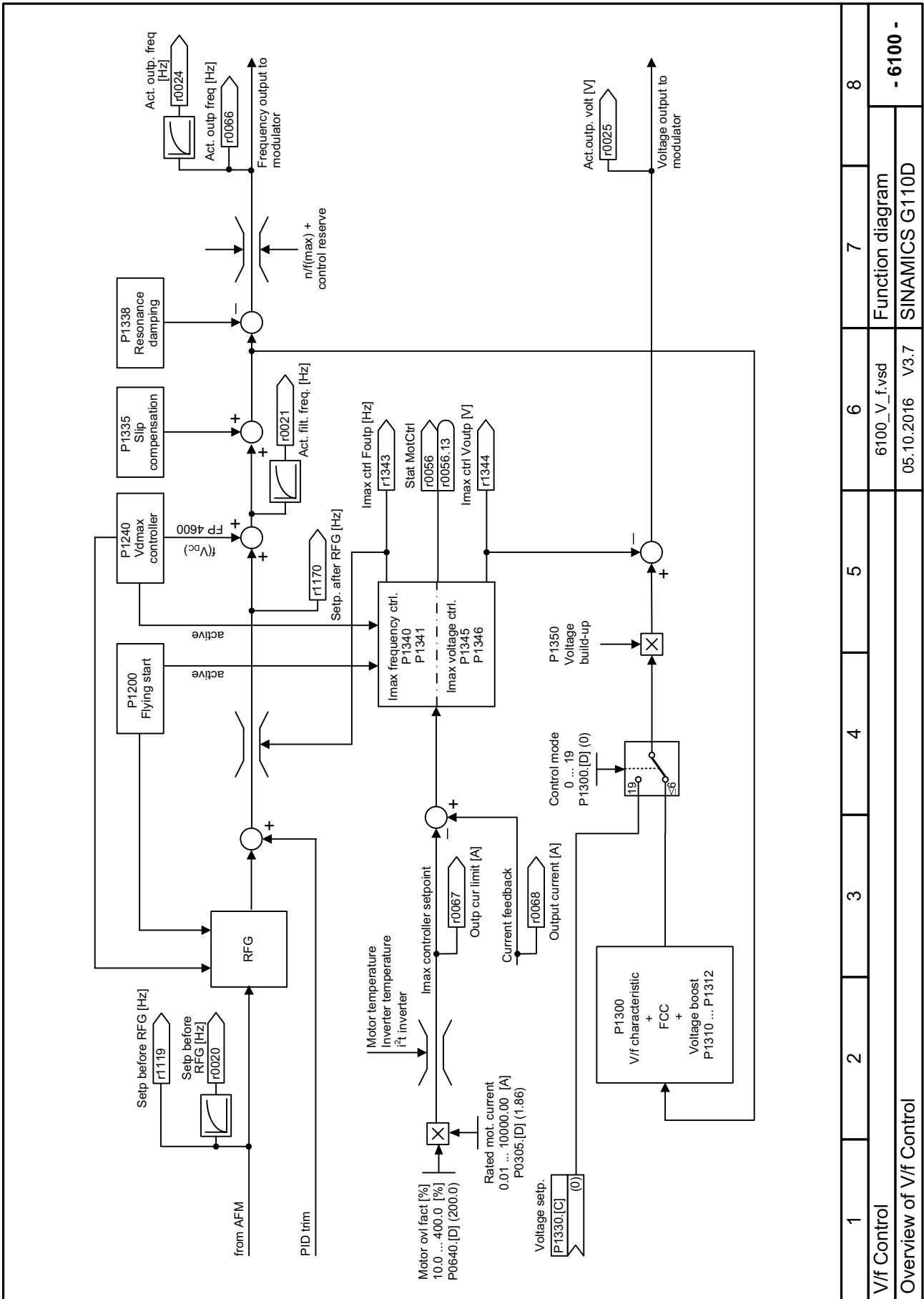

Fig. 3-30 6100 – Overview of V/f Control

1	2	3	4	5	6	7	8
V/f Control							
Overview of V/f Control							
6100_V_f.vsd						Function diagram	
05.10.2016 V3.7						SINAMICS G110D	
- 6100 -							

3.10 Display values

Function diagrams

8000 – Display values

3-215

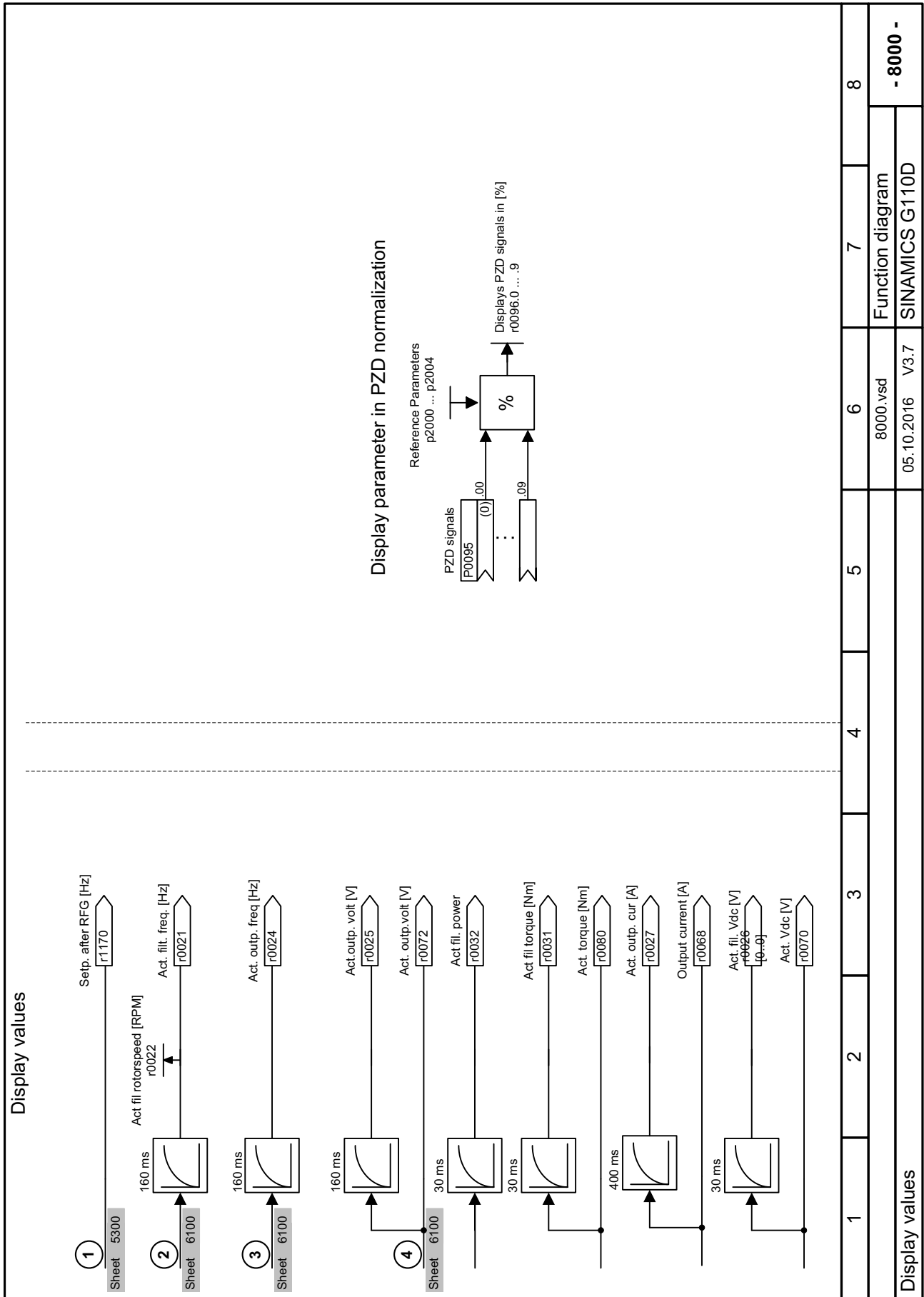

Fig. 3-31 8000 – Display values

Faults and Alarms

4

Contents

4.1	Faults and Alarms – Overview	4-218
4.2	List of Faults and Alarms	4-219

4.1 Faults and Alarms – Overview

Fault messages

In the event of a fault, the inverter stops with the preset reaction (refer to „Reaction:“ in Section 3.2) and changes to the state „fault“. If there are reactions in brackets it is possible to change to this fault reaction via parameters P2100 and P2101.

Fault messages are stored in parameter r0947 under their code number (e.g. F0003 = 3). The associated error value is found in parameter r0949. The value 0 is entered if a fault has no error value. It is furthermore possible to read out the point in time that a fault occurred (r0948) and the number of fault messages (P0952) stored in Parameter r0947.

Fault acknowledge

To reset the fault, one of the methods listed below can be used:

1. Cycle the power to the drive
2. IOP: Diagnostics menu --> Active faults/alarms --> Acknowledge all
3. Via a Digital Input (factory setting: DI2)
4. Via control word 1, bit 07

Warning messages

Warning messages are stored in parameter r2110 under their code number (e.g. A0503 = 503) and can be read out from there.

4.2 List of Faults and Alarms

Product: G110D, Version: 3700000, Language: eng,
Objects: Sinamics G110D

F00001 (N)	Overcurrent
Reaction:	OFF 2
Acknowledge:	Quit fault eg. via DI2
Cause:	<ul style="list-style-type: none">• Motor power (p0307) does not correspond to the inverter power (r0206)• Motor lead short circuit• Earth faults r0949 = 0: HW reported r0949 = 1: SW reported
Remedy:	Check the following: <ul style="list-style-type: none">• Motor power (p0307) must correspond to inverter power (r0206).• Cable length limits must not be exceeded.• Motor cable and motor must have no short-circuits or earth faults.• Motor parameters must match the motor in use.• Value of stator resistance (p0350) must be correct.• Motor must not be obstructed or overloaded.• Increase Ramp-up time (p1120).• Reduce Starting boost level (p1312).
<hr/>	
F00002	Overvoltage
Reaction:	OFF 2
Acknowledge:	Quit fault eg. via DI2
Cause:	<ul style="list-style-type: none">• Main supply voltage too high• Motor is in regenerative mode r0949 = 0: HW reported r0949 = 1 or 2: SW reported
Remedy:	Check the following: <ul style="list-style-type: none">• Supply voltage (p0210) must lie within limits indicated on rating plate.• Ramp-down time (p1121) must match inertia of load.• Required braking power must lie within specified limits.• Vdc controller must be enabled (p1240) and parameterized properly.
Note:	Regenerative mode can be caused by fast ramp downs or if the motor is driven by an active load. Higher inertia requires longer ramp times; otherwise, apply braking resistor.
<hr/>	
F00003	Undervoltage
Reaction:	OFF 2
Acknowledge:	Quit fault eg. via DI2
Cause:	<ul style="list-style-type: none">• Main supply failed.• Shock load outside specified limits. r0949 = 0: HW reported r0949 = 1, 2 or 24: SW reported
Remedy:	Check Supply voltage (p0210). Check 24V supply to control board
Note:	If the CU is powered externally with DC 24 V and the power module is not connected, A0503 appears. Although this alarm appears, the inverter does not trip with F0003 after an ON command.

F00004 Inverter Over Temperature

Reaction: OFF 2

Acknowledge: Quit fault eg. via DI2

- Cause:**
- Inverter overloaded
 - Ventilation inadequate
 - Pulse frequency too high
 - Ambient temperature too high
 - Fan inoperative

- Remedy:** Check the following:
- Load or load cycle too high?
 - Motor power (p0307) must match inverter power (r0206)
 - Pulse frequency must be set to default value
 - Ambient temperature too high?
 - Fan must turn when inverter is running
-

F00005 Inverter I2T

Reaction: OFF 2

Acknowledge: Quit fault eg. via DI2

- Cause:**
- Inverter overloaded.
 - Load cycle too demanding.
 - Motor power (p0307) exceeds inverter power capability (r0206).

- Remedy:** Check the following:
- Load cycle must lie within specified limits.
 - Motor power (p0307) must match inverter power (r0206)
-

F00006 Chip temperature rise exceeds critical levels

Reaction: OFF 2

Acknowledge: Quit fault eg. via DI2

- Cause:**
- Load at start-up is too high
 - Load step is too high
 - Ramp-up rate is too fast

- Remedy:** Check the following:
- Load or load step too high?
 - Increase ramp-up time (P1120).
 - Motor power (P0307) must match inverter power (r0206).
 - Use setting P0290 = 0 or 2 for preventing F00006.
-

F00011 Motor Over Temperature

Reaction: OFF 2 (OFF 3)

Acknowledge: Quit fault eg. via DI2

Cause: Motor overloaded

- Remedy:** Check the following:
- Load or load step too high?
 - Motor nominal overtemperatures (p0626 - p0628) must be correct
 - Motor temperature warning level (p0604) must match
-

F00012 Inverter temp. signal lost

Reaction: OFF 1 (OFF 2)

Acknowledge: Quit fault eg. via DI2

Cause: Wire breakage of inverter temperature (heat sink) sensor.

Remedy:

F00015	Motor temperature signal lost
Reaction:	OFF 2 (OFF 3)
Acknowledge:	Quit fault eg. via DI2
Cause:	Open or short circuit of motor temperature sensor. If signal loss is detected, temperature monitoring switches over to monitoring with the motor thermal model.
Remedy:	Check the following: <ul style="list-style-type: none">• the connection of the motor temperature sensor to the control unit• the setting of p0601
Note:	If the CU is powered externally with DC 24 V, but no supply voltage to the power module available, the loss of the motor temperature signal will not be detected.

F00020	Mains Phase Missing
Reaction:	OFF 2 (OFF 3)
Acknowledge:	Quit fault eg. via DI2
Cause:	Fault occurs if one of the three input phases are missed and the pulses are enabled and drive is loaded
Remedy:	Check the input wiring of the mains phases

F00021	Earth fault
Reaction:	OFF 2
Acknowledge:	Quit fault eg. via DI2
Cause:	Fault occurs if the sum of the phase currents is higher than 5 % of the nominal inverter current.
Remedy:	
Note:	Framesizes D to F: this fault only occurs on inverters that have 3 current sensors.

F00022	Power stack HW fault
Reaction:	OFF 2
Acknowledge:	Quit fault eg. via DI2
Cause:	This hardware fault caused by the following events: <ul style="list-style-type: none">• DC-link overcurrent = short circuit of IGBT• Short circuit of chopper
Remedy:	Contact Service Department or change inverter

F00023	Output phase fault
Reaction:	OFF 2 (OFF 3)
Acknowledge:	Quit fault eg. via DI2
Cause:	One output phase is disconnected.
Remedy:	Check motor connection.

F00026	Supply to Gate Driver Not Enabled
Reaction:	OFF 2
Acknowledge:	Quit fault eg. via DI2
Cause:	Gate driver not enabled.
Remedy:	Contact Service Department.

F00027	Overcurrent on W phase
Reaction:	OFF 2
Acknowledge:	Quit fault eg. via DI2
Cause:	This hardware fault caused by the following events: <ul style="list-style-type: none">• Over current trip on W phase• Earth Fault
Remedy:	Check Inverter and Motor wiring

F00029 EM brake overcurrent

Reaction: OFF 2
Acknowledge: Quit fault eg. via DI2
Cause:
Remedy: Check voltage and current of the connected holding brake (max. 180 V / 1 A)

F00030 Fan failure

Reaction: OFF 2 (OFF 3)
Acknowledge: Quit fault eg. via DI2
Cause: Fan no longer working.
Remedy: Need a new fan.

F00035 Auto restart after n

Reaction: OFF 2 (OFF 3)
Acknowledge: Power on
Cause: Auto restart attempts exceed value of p1211.
Remedy:

F00041 Motor Data Identification Failure

Reaction: OFF 2
Acknowledge: Quit fault eg. via DI2
Cause: Motor data identification failed.

- r0949 = 0: Load missing
- r0949 = 1: Current limit level reached during identification.
- r0949 = 2: Identified stator resistance less than 0.1% or greater than 100%.
- r0949 = 3: Identified rotor resistance less than 0.1% or greater than 100%.
- r0949 = 4: Identified stator reactance less than 50% and greater than 500%
- r0949 = 5: Identified main reactance less than 50% and greater than 500%
- r0949 = 6: Identified rotor time constant less than 10ms or greater than 5s
- r0949 = 7: Identified total leakage reactance less than 5% and greater than 50%
- r0949 = 20: Identified IGBT on-voltage less than 0.5 V or greater than 10 V
- r0949 = 30: Current controller at voltage limit
- r0949 = 40: Inconsistence of identified dataset, at least one identification failed
- r0949 = 41: Writing of calculated magnetizing current P0320 failed
- r0949 = 42: Writing of identified stator resistance failed
- r0949 = 43: Writing of identified rotor resistance P0354 failed
- r0949 = 44: Writing of identified rotor time constant P0622 failed
- r0949 = 45: Writing of identified mutual reactance P0360 failed
- r0949 = 46: Writing of identified stator leakage reactance P0356 failed
- r0949 = 47: Writing of identified rotor leakage reactance P0358 failed
- r0949 = 48: Writing of identified on voltage P1825 failed.
- r0949 = 49: Writing of the identified dead time compensation P1828 failed

Percentage values based on the impedance $Z_b = V_{mot,nom} / \sqrt{3} / I_{mot,nom}$

Remedy: Check the following:

- r0949 = 0: is the motor connected to the inverter.
- r0949 = 1 - 49: are the motor data in p0304 - p0311 correct.
- Check what type of motor wiring is required (star, delta).

F00051 Parameter EEPROM Fault

Reaction: OFF 2

Acknowledge: Quit fault eg. via DI2

Cause: Read or write failure while access to EEPROM.
This can also be caused by the EEPROM being full, too many parameters have been changed.

Remedy:

- Must be Power Cycled to cancel this bug as some parameters may not be read correct.
- Factory Reset and new parameterization, if power cycle does not remove fault.
- Change some parameters back to default values if the EEPROM is full, then power cycle.
- Contact Service Department or change inverter.

Note:

- r0949 = 1: EEPROM Full
- r0949 = 1000 + Block No: Reading data block failed
- r0949 = 2000 + Block No: Reading data block timeout
- r0949 = 3000 + Block No: Reading data block CRC failed
- r0949 = 4000 + Block No: Writing data block failed
- r0949 = 5000 + Block No: Writing data block timeout
- r0949 = 6000 + Block No: writing data block verify failed
- r0949 = 7000 + Block No: Reading data block at wrong time
- r0949 = 8000 + Block No: writing data block at wrong time
- r0949 = 9000 + Block No: Factory Reset did not work because restart or power failure

F00052 Power stack SW fault

Reaction: OFF 2

Acknowledge: Quit fault eg. via DI2

Cause: Read failure for power stack information or invalid data.

Remedy:

- Powercycle inverter
- Contact Service Department or change inverter

Note:

- r0949 = 1: Failed reading PS identity
- r0949 = 2: PS identity wrong
- r0949 = 3: Failed reading PS version
- r0949 = 4: PS version wrong
- r0949 = 5: Start of Part 1 PS data wrong
- r0949 = 6: PS number of temp. sensor wrong
- r0949 = 7: PS number of application wrong
- r0949 = 8: Start of Part 3 PS data wrong
- r0949 = 9: Reading PS data string wrong
- r0949 = 10: PS CRC failed
- r0949 = 11: PS is blank
- r0949 = 15: Failed CRC of PS block 0
- r0949 = 16: Failed CRC of PS block 1
- r0949 = 17: Failed CRC of PS block 2
- r0949 = 20: PS invalid
- r0949 = 30: Directory size wrong
- r0949 = 31: Directory ID wrong
- r0949 = 32: Invalid block
- r0949 = 33: File size wrong
- r0949 = 34: Data section size wrong
- r0949 = 35: Block section size wrong
- r0949 = 36: RAM size exceeded
- r0949 = 37: Parameter size wrong
- r0949 = 38: Device header wrong
- r0949 = 39: Invalid file file pointer
- r0949 = 40: Scaling block version wrong
- r0949 = 41: Calibration block version wrong

- r0949 = 50: Wrong serial number format
- r0949 = 51: Wrong serial number format start
- r0949 = 52: Wrong serial number format end
- r0949 = 53: Wrong serial number format month
- r0949 = 54: Wrong serial number format day
- r0949 = 1000 + addr: PS read data failed
- r0949 = 2000 + addr: PS write data failed
- r0949 = 3000 + addr: PS read data wrong time
- r0949 = 4000 + addr: PS write data wrong time
- r0949 = 5000 + addr: PS read data invalid
- r0949 = 6000 + addr: PS read data invalid

F00060 Asic Timeout

Reaction: OFF 2

Acknowledge: Quit fault eg. via DI2

Cause: Internal communications failure:

- r0949 = 0: HW reported Link Fail
- r0949 = 1: SW reported Link Fail
- r0949 = 5: No comms with PS asic during powerup to read ps data
- r0949 = 6: Feedback is not disabled for reading PS data
- r0949 = 7: During PS download, message didn't transmit to disable feedback

Remedy: Fault appears sporadically:

- Communication failure due to EMC problems
- Check - and if necessary - improve EMC
- Use EMC filter

Fault appears immediately when mains voltage is applied and an ON command is given.

- If fault persists, change inverter.
- Contact Service Department.

F00061 Par Cl. MMC-PS not fitted Fault

Reaction: OFF 2

Acknowledge: Quit fault eg. via DI2

Cause: MMC-PS Cloning Failed.

- r0949 = 0: MMC-PS not connected or incorrect MMC-PS type or MMC failed to initialize for automatic cloning
- r0949 = 1: MMC-PS cannot write to MMC
- r0949 = 2: MMC-PS file not available
- r0949 = 3: MMC-PS cannot read the file
- r0949 = 4: MMC-PS problems in the clone File (e.g CRC)

Remedy:

- r0949 = 0: Use MMC with FAT12 or FAT16 format or correct MMC-PS type, or fit a MMC-PS to drive.
- r0949 = 1: Check MMC (e.g is MMC full) - Format MMC again to FAT16
- r0949 = 2: Put the correct named file in the correct directory /USER/SINAMICS/DATA.
- r0949 = 3: Make sure file is accessible - Recreate file if possible
- r0949 = 4: File has been changed - Recreate File

F00062 Par Cl. MMC-PS contents invalid

Reaction: OFF 2

Acknowledge: Quit fault eg. via DI2

Cause: File exists but the contents are not valid Control Word Corruption.

Remedy: Recopy and ensure operation completes.

F00063 Par Cl. MMC-PS contents incompatible

Reaction: OFF 2
Acknowledge: Quit fault eg. via DI2
Cause: File exists but was not the correct drive type.
Remedy: Ensure clone from compatible drive type.

F00064 Drive attempted to do an automatic clone during startup

Reaction: OFF 2
Acknowledge: Quit fault eg. via DI2
Cause: No Clone00.bin File in the correct directory /USER/SINAMICS/DATA.
Remedy: If a automatic clone is required:
- Insert MMC with correct File and power cycle.
If no automatic clone is required:
- Remove MMC if not needed and power cycle.
- Reset P8458 = 0 and power cycle.
Note: Fault can only be cleared by a power cycle.

F00070 PLC setpoint fault

Reaction: OFF 2 (OFF 3)
Acknowledge: Quit fault eg. via DI2
Cause: No setpoint values from PLC during telegram off time.

Remedy:

- r0949 = 10: No low level comms with ASI chip
 - r0949 = 11: Lost comms with Master
 - r0949 = 13: ASI module not ready, Comms problem with drive
 - r0949 = 10: Check P2022 selected to the right slave type.
 - r0949 = 11: Check and improve - if necessary - the fieldbus specific off time value in P2040 (ASI).
 - r0949 = 13: Change P2022 to a different value and then back.
 - Acknowledge fault.
 - If fault persists, contact Service Department or change inverter.
-

F00071 USS setpoint fault

Reaction: OFF 2 (OFF 3)
Acknowledge: Quit fault eg. via DI2
Cause: No setpoint values from USS during telegram off time
Remedy: Check and if necessary improve the monitoring time in the STARTER SW while getting the command source.
Check USS master

F00073 Control Panel setpoint fault

Reaction: OFF 2 (OFF 3)
Acknowledge: Quit fault eg. via DI2
Cause: No setpoint values from Control Panel during telegram off time
Remedy:

- Check and improve - if necessary - the value in p3984
- Acknowledge fault
- if fault persists, contact Service Department or change inverter

F00080 AI lost Input Signal

Reaction: OFF 2 (OFF 3)
Acknowledge: Quit fault eg. via DI2
Cause:

- Broken wire
- Signal out of limits

Remedy:

F00085	External Fault
Reaction:	OFF 2 (OFF 3)
Acknowledge:	Quit fault eg. via DI2
Cause:	External fault triggered via command input via control word 2, bit 13."
Remedy:	<ul style="list-style-type: none"> • Check P2106. • Disable control word 2 bit 13 as command source. • Disable terminal input for fault trigger.
F00100	Watchdog Reset
Reaction:	OFF 2
Acknowledge:	Quit fault eg. via DI2
Cause:	Software Error
Remedy:	Contact Service Department or change inverter.
F00101 (N)	Stack Overflow
Reaction:	OFF 2
Acknowledge:	Quit fault eg. via DI2
Cause:	Software error or processor failure.
Remedy:	Contact Service Department or change inverter.
F00221	PID Feedback below min. Value
Reaction:	OFF 2 (OFF 3)
Acknowledge:	Quit fault eg. via DI2
Cause:	PID Feedback below min. value p2268.
Remedy:	<ul style="list-style-type: none"> • Change value of p2268. • Adjust feedback gain.
F00222	PID Feedback above max. Value
Reaction:	OFF 2 (OFF 3)
Acknowledge:	Quit fault eg. via DI2
Cause:	PID feedback above max. value p2267.
Remedy:	<ul style="list-style-type: none"> • Change value of p2267. • Adjust feedback gain.
F00350	Configuration vector for the drive failed
Reaction:	OFF 2
Acknowledge:	Quit fault eg. via DI2
Cause:	<p>During startup the drive checks if the configuration vector (SZL vector) has been programmed correctly and if hw matches the programmed vector. If not the drive will trip.</p> <ul style="list-style-type: none"> • r0949 = 1: Internal Failure - No HW Configuration Vector available. • r0949 = 2: Internal Failure - No SW Configuration Vector available. • r0949 = 11: Internal Failure - CU Code not supported. • r0949 = 12: Internal Failure - SW Vector not possible. • r0949 = 13: Wrong power module fitted. • r0949 > 1000: Internal failure - Wrong IO Board fitted.
Remedy:	<p>Internal Failures cannot be fixed.</p> <p>r0949 = 13 - Make sure the right power module is fitted.</p>
Note:	Fault needs power cycle to be acknowledged.

F00395 **Acceptance Test / Confirmation pending**

Reaction: OFF 2

Acknowledge: Quit fault eg. via DI2

Cause: This fault occurs after a Startup Clone. It can also be caused by a faulty read from the EEPROM, see F0051 for more details.

A startup clone could have changed and might not match the application.
This parameterset needs to be checked before the drive can start a motor.

- r0949 = 3/4: Powerstack data change
- r0949 = 5: Startup Clone via MMC has been performed

Remedy: The current parameterset needs to be checked and confirmed by clearing the fault.

F00452 **Belt Failure**

Reaction: OFF 2 (OFF 3)

Acknowledge: Quit fault eg. via DI2

Cause: Load conditions on motor indicate belt failure or mechanical fault.

- r0949 = 0: trip low torque/speed
- r0949 = 1: trip high torque/speed

Remedy: Check the following:

- No breakage, seizure or obstruction of drive train.
- Apply lubrication if required.

Check the following parameters for correct function:

- p2192 (delay time for permitted deviation)
- p2182 (threshold frequency f1)
- p2183 (threshold frequency f2)
- p2184 (threshold frequency f3)

If using the torque envelope, check parameters:

- p2185 (upper torque threshold 1)
 - p2186 (lower torque threshold 1)
 - p2187 (upper torque threshold 2)
 - p2188 (lower torque threshold 2)
 - p2189 (upper torque threshold 3)
 - p2190 (lower torque threshold 3)
-

A00501 **Current Limit**

Reaction: NONE

Acknowledge: NONE

Cause:

- Motor power does not correspond to the inverter power
- Motor leads are too long
- Earth faults

Remedy: Check the following:

- Motor power (P0307) must correspond to inverter power (r0206).
 - Cable length limits must not be exceeded.
 - Motor cable and motor must have no short-circuits or earth faults
 - Motor parameters must match the motor in use
 - Value of stator resistance (P0350) must be correct
 - Motor must not be obstructed or overloaded
 - Increase Ramp-up time (P1120)
 - Reduce Starting boost level (P1312)
-

A00502 **Overvoltage limit**

Reaction: NONE

Acknowledge: NONE

Cause: Overvoltage limit is reached. This warning can occur during ramp down, if the Vdc controller is disabled (P1240 = 0).

Remedy: If this warning is displayed permanently, check drive input voltage.

A00503	UnderVoltage Limit
Reaction:	NONE
Acknowledge:	NONE
Cause:	<ul style="list-style-type: none"> • Main supply failed. • Main supply and consequently DC-link voltage (r0026) below specified limit.
Remedy:	Check main supply voltage.
A00504	Inverter OverTemperature
Reaction:	NONE
Acknowledge:	NONE
Cause:	Warning level of inverter heat sink temperature, warning level of chip junction temperature, or allowed change in temperature on chip junction is exceeded, resulting in pulse frequency reduction and/or output frequency reduction (depending on parameterization in P0290).
Remedy:	<p>Note:</p> <p>r0037 = 0: Heat sink temperature r0037 = 1: Chip junction temperature (includes heat sink)</p> <p>Check the following:</p> <ul style="list-style-type: none"> • Ambient temperature must lie within specified limits • Load conditions and load steps must be appropriate • Fan must turn when drive is running
A00505	Inverter I2T
Reaction:	NONE
Acknowledge:	NONE
Cause:	Warning level exceeded, current will be reduced if parameterized (P0610 = 1)
Remedy:	Check that load cycle lies within specified limits.
A00506	IGBT junction temperature rise warning
Reaction:	NONE
Acknowledge:	NONE
Cause:	Overload warning. Difference between heat sink and IGBT junction temperature exceeds warning limits.
Remedy:	Check that load steps and shock loads lie within specified limits.
A00507	Inverter temp. signal lost
Reaction:	NONE
Acknowledge:	NONE
Cause:	Inverter heatsink temperature signal loss. Possible sensor fallen off.
Remedy:	<ul style="list-style-type: none"> • Contact Service Department • Change inverter
A00508	Control board temperature rise warning
Reaction:	NONE
Acknowledge:	NONE
Cause:	Control board temperature reached a warning level
Remedy:	-Check drive ambient temperature
A00511	Motor OverTemperature I2T
Reaction:	NONE
Acknowledge:	NONE
Cause:	<ul style="list-style-type: none"> • Motor overloaded. • Load cycles or load steps too high.
Remedy:	Independently of the kind of temperature determination check: <ul style="list-style-type: none"> • P0604 motor temperature warning threshold • P0625 motor ambient temperature

If P0601 = 0 or 1, check the following:

- Check if name plate data are correct? If not perform quick commissioning. Accurate equivalent circuit data can be found by performing motor identification (P1910 = 1).
- Check if motor weight (P0344) is reasonable. Change if necessary.
- Via P0626, P0627, P0628 the standard overtemperatures can be changed, if the motor is not a Siemens standard motor.

If P0601 = 2, Check the following:

- Check if temperature shown in r0035 is reasonable.
- Check if the sensor is a KTY84 (other sensors are not supported)

A00523	Output fault
Reaction:	NONE
Acknowledge:	NONE
Cause:	One phase of output is disconnected.
Remedy:	Check motor connection.

A00530	One of the fans has failed
Reaction:	NONE
Acknowledge:	NONE
Cause:	Fan no longer working.
Remedy:	Replace Fan.

A00535	Braking Resistor Overload
Reaction:	NONE
Acknowledge:	NONE
Cause:	The braking energy is too large. The braking resistor is not suited for the application.
Remedy:	Reduce the braking energy. Use a braking resistor with a higher rating.

A00541	Motor Data Identification Active
Reaction:	NONE
Acknowledge:	NONE
Cause:	Motor data identification (P1910) selected or running.
Remedy:	

A00564	MMC Plugged During Operation
Reaction:	NONE
Acknowledge:	NONE
Cause:	MMC-PS Plugged During Operation and none was present at startup. Therefore, possible corruption of current data-set on next power cycle from Automatic Cloning at Startup.
Remedy:	Remove MMC-PS from drive.

A00570	Key switch in OFF state.
Reaction:	NONE
Acknowledge:	NONE
Cause:	The key switch is in off state.
Remedy:	Move switch to local or remote position to run drive. If fault is active, moving the key from OFF position to local/remote will clear the active faults.

A00571 Key switch in LOCAL mode

Reaction: NONE
Acknowledge: NONE
Cause: The key switch is in local mode.
Remedy: In this position, drive can only be run from local buttons.
 Move key to remote position to run drive from other sources such as ASi or USS.

A00600 RTOS Overrun Warning

Reaction: NONE
Acknowledge: NONE
Cause: Internal time slice overrun
Remedy: Contact Service Department

A00910 Vdc-max controller de-activated

Reaction: NONE
Acknowledge: NONE
Cause: Occurs

- if main supply voltage (P0210) is permanently too high.
- if motor is driven by an active load, causing motor to go into regenerative mode.
- at very high load inertias, when ramping down.

Remedy: Check the following:

- Input voltage must lie within range.
- Load must be match.
- In certain cases apply braking resistor.

A00911 Vdc-max controller active

Reaction: NONE
Acknowledge: NONE
Cause: Vdc max controller is active; so ramp-down times will be increased automatically to keep DC-link voltage (r0026) within limits (P2172).
Remedy: Check the following:

- Supply voltage must lie within limits indicated on rating plate.
- Ramp-down time (P1121) must match inertia of load.

Note: Higher inertia requires longer ramp times; otherwise, apply braking resistor.

A00922 No load applied to inverter

Reaction: NONE
Acknowledge: NONE
Cause: No Load is applied to the inverter.
 As a result, some functions may not work as under normal load conditions.
Remedy: Check that motor is connected to inverter.

A00923 Both JOG Left and JOG Right are requested

Reaction: NONE
Acknowledge: NONE
Cause: Both JOG right and JOG left (P1055/P1056) have been requested. This freezes the RFG output frequency at its current value.
Remedy: Do not press JOG right and left simultaneously.

A00936 PID Autotuning Active

Reaction: NONE
Acknowledge: NONE
Cause: PID Autotuning (P2350) selected or running
Remedy: Warning disappears when PID Autotuning has finished.

A00952	Belt Failure Detected
Reaction:	NONE
Acknowledge:	NONE
Cause:	Load conditions on motor indicate belt failure or mechanical fault.
Remedy:	<p>Check the following:</p> <ul style="list-style-type: none">• No breakage, seizure or obstruction of drive train.• Apply lubrication if required. <p>Check the following parameters for correct function:</p> <ul style="list-style-type: none">- p2192 (delay time for permitted deviation)- p2182 (threshold frequency f1)- p2183 (threshold frequency f2)- p2184 (threshold frequency f3) <p>If using the torque envelope, check parameters:</p> <ul style="list-style-type: none">- p2185 (upper torque threshold 1)- p2186 (lower torque threshold 1)- p2187 (upper torque threshold 2)- p2188 (lower torque threshold 2)- p2189 (upper torque threshold 3)- p2190 (lower torque threshold 3)

ASCII-Table

A

The following table contains the decimal and hexadecimal notation of selected ASCII indications.

Table A-1 ASCII-Table (in part)

Indication	Decimal	Hexadecimal	Indication	Decimal	Hexadecimal
Space	32	20	H	72	48
-	45	2D	I	73	49
0	48	30	J	74	4A
1	49	31	K	75	4B
2	50	32	L	76	4C
3	51	33	M	77	4D
4	52	34	N	78	4E
5	53	35	O	79	4F
6	54	36	P	80	50
7	55	37	Q	81	51
8	56	38	R	82	52
9	57	39	S	83	53
A	65	41	T	84	54
B	66	42	U	85	55
C	67	43	V	86	56
D	68	44	W	87	57
E	69	45	X	88	58
F	70	46	Y	89	59
G	71	47	Z	90	5A

List of Abbreviations

Abbreviations used with the SINAMICS G110 Products:

Abbreviation	Meaning
A	
AC	Alternating current
A/D	Analog digital converter
ADR	Address
AFM	Additional frequency modification
AG	Automation unit
AI	Analog input
AK	Request identifier
AO	Analog output
ASIC	Application specific integrated circuit
ASP	Analog setpoint
ASVM	Asymmetric space vector modulation
B	
BCC	Block check character
BCD	Binary-coded decimal code
BI	Binector input
BIA	Berufsgenossenschaftliches Institut für Arbeitssicherheit
BICO	Binector/connector
BO	Binector output
C	
C	Commissioning
CB	Communication board
CCW	Counter-clockwise
CDS	Command data set
CI	Connector input
CM	Configuration management
CMD	Command
CO	Cconnector output
CO/BO	Connector output/Binector output
COM	Common (terminal is connected to NO or NC)
CT	Commissioning, ready to run
CU	Control unit

Abbreviation	Meaning
CUT	Commissioning, run, ready to run
CW	Clockwise
D	
D/A	Digital analog converter
DC	Digital analog converter
DDS	Drive data set
DI	Digital input
DIP	DIP switch
DO	Digital output
DP	Distributed I/Os
DS	Drive state
E	
ECD	Equivalent circuit diagram
EEC	European Economic Community
EEPROM	Electrical erasable programmable read-only memory
ELCB	Earth leakage circuit breaker
EMC	Electromagnetic compatibility
EMF	Electromagnetic force
ES	Engineering System
F	
FAQ	Frequently asked question
FB	Function block
FFB	Freely Assignable Function block
FCC	Flux current control
FCL	Fast current limiting
FF	Fixed frequency
FFB	Free function block
FOC	Field orientated control
FREQ	Frequency
FSA	Frame size A
FSB	Frame size B
FSC	Frame size C
FSD	Frame size D
FSE	Frame size E
FSF	Frame size F
G	
GSD	Device data file (Geräte Stamm Datei)
GSG	Getting started guide
GUI ID	Global unique identifier
H	
HIW	Main actual value

Abbreviation	Meaning
HMI	Human machine interface
HO	High Overload (Constant Torque)
HSW	Main setpoint
HTL	High-voltage transistor logic
I	
I/O	In-/output
IBN	Commissioning
IGBT	Insulated gate bipolar transistor
IND	Sub-index
J	
JOG	JOG
K	
KIB	Kinetic buffering
L	
LCD	Liquid crystal display
LED	Light emitting diode
LGE	Length
LO	Light Overload (Variable Torque)
LWL	Fiber Optic conductor
M	
MHB	Motor holding brake
MLP	Multi-Language Pack
MOP	Motor operated potentiometer
N	
NC	Normally closed
NEMA	National Electrical Manufacturers Association
NO	Normally open
O	
OLM	Optical Link Module
OLP	Optical Link Plug
OP	Operator Panel
OPI	Operating Instructions
P	
PID	Proportional, integral, derivative controller
PKE	Parameter ID
PKW	Parameter ID value area (Parameterkennung Wert)
PLC	Programmable logic control
PM	Power module
PM-IF	Power module interface
PNU	Parameter Number
PPO	Parameter process data object

Abbreviation	Meaning
PTC	Positive temperature coefficient
PWE	Parameter value
PWM	Pulse-width modulation
Pxxxx	Write parameter
PZD	Process data area (Prozessdaten)
Q	
QC	Quick commissioning
R	
RAM	Random-access memory
RCCB	Residual current circuit breaker
RCD	Residual current device
RFG	Ramp-function generator
RFI	Radio frequency interference
ROM	Read-only memory
RPM	Revolutions per minute
rxxxx	read-only parameters of analogue signals
S	
SBC	Safe Break Control
SLVC	Sensorless vector control
SLS	Safe-Limited Speed
SOL	Serial option link
SS1	Safe stop 1
STO	Safe torque off
STW	Control word
STX	Start of text
SVM	Space vector modulation
T	
TTL	Transistor-transistor logic
U	
USS	Universal serial interface
V	
V/f	Voltage/frequency
VC	Vector control
VT	Variable torque
W	
WEA	Automatic restart
Z	
ZSW	Status word
ZUSW	Additional setpoint

Index

C

Numbers

- 0010
 - Symbols in funktion diagrams, 3-177
 - 1100
 - General Overview, 3-179
 - 1200
 - Connection of External and Internal Set-points, 3-180
 - 2000
 - Digital Inputs (DI), 3-182
 - 2200
 - Analog Input (AI), 3-183
 - 2500
 - USS on RS232, Receiving, 3-184
 - 2510
 - USS on RS232, Transmitting, 3-185
 - 3100
 - Motor Potentiometer, 3-187
 - 3200
 - Fixed Frequency (FF) Direct Selection (P1016 = 1), 3-188
 - 3210
 - Fixed Frequency (FF) Binary Selection (P1016 = 2), 3-189
 - 3300
 - Fixed PID setpoint, Direct Selection (P2216 = 1), 3-190
 - 3310
 - Fixed PID setpoint, Binary Selection (P2216 = 2), 3-191
 - 3400
 - PID Motor Potentiometer (PID-MOP), 3-192
 - 4100
 - Monitoring word 1 (r2197, bits 00 - 04), 3-194
 - 4110
 - Monitoring word 1 (r2197, bits 05 - 12), 3-195
 - 4115
 - Monitoring word 1 (r2197, bits 09 - 10), 3-196
 - 4130
 - Monitoring word 2 (r2198, bits 05 - 08), 3-197
 - 4140
 - Monitoring word 2 (r2198, bits 11 - 12), 3-198
 - 4150
 - Control word1 (r0054), 3-199
 - 4160
 - Control word 2 (r0055), 3-200
 - 4170
 - Status word 1 (r0052), 3-201
 - 4180
 - Status word 2 (r0053), 3-202
 - 4600
 - Vdc_max control, 3-203
 - 4800
 - AND-, OR-, XOR- and NOT- Elements, 3-205
 - 4810
 - FlipFlops, 3-206
 - 5000
 - Setpoint channel and Motor control, 3-208
 - 5100
 - PID Controller, 3-209
 - 5200
 - Additional Frequency Modifications, 3-210
 - 5300
 - Ramp Function Generator, 3-211
 - 6100
 - Overview of V/f Control, 3-213
 - 8000
 - Display values, 3-215
- ## A
- A00501, 4-227
 - A00502, 4-227
 - A00503, 4-228
 - A00504, 4-228
 - A00505, 4-228
 - A00506, 4-228
 - A00507, 4-228
 - A00508, 4-228
 - A00511, 4-228

- A00523, 4-229
- A00530, 4-229
- A00535, 4-229
- A00541, 4-229
- A00564, 4-229
- A00570, 4-229
- A00571, 4-230
- A00600, 4-230
- A00910, 4-230
- A00911, 4-230
- A00922, 4-230
- A00923, 4-230
- A00936, 4-230
- A00952, 4-231
- Adjustable parameter, 2-18
- Alarm
 - Alarm messages, 4-218
 - List of Alarm messages, 4-219
- ASCII-Table, A-233
- B**
- Bit field (Parameters), 2-23
- C**
- Calculated (Parameters), 2-21
- Can be changed (Parameters), 2-22
- Connector, 2-166
- Contents
 - ASCII-Table, A-233
 - Contents overview, 2-11
 - List of Abbreviations, B-235
- D**
- Data set (Parameters), 2-22
- Data type (Parameters), 2-20
- Dependency (Parameters), 2-23
- Description (Parameters), 2-23
- F**
- F00001 (N), 4-219
- F00002, 4-219
- F00003, 4-219
- F00004, 4-220
- F00005, 4-220
- F00006, 4-220
- F00011, 4-220
- F00012, 4-220
- F00015, 4-221
- F00020, 4-221
- F00021, 4-221
- F00022, 4-221
- F00023, 4-221
- F00026, 4-221
- F00027, 4-221
- F00029, 4-222
- F00030, 4-222
- F00035, 4-222
- F00041, 4-222
- F00051, 4-223
- F00052, 4-223
- F00060, 4-224
- F00061, 4-224
- F00062, 4-224
- F00063, 4-225
- F00064, 4-225
- F00070, 4-225
- F00071, 4-225
- F00073, 4-225
- F00080, 4-225
- F00085, 4-226
- F00100, 4-226
- F00101 (N), 4-226
- F00221, 4-226
- F00222, 4-226
- F00350, 4-226
- F00395, 4-227
- F00452, 4-227
- Fault messages
 - List of all Fault messages, 4-219
- Function diagrams Display values
 - Display values, 3-215
- Function diagrams External Interfaces
 - Analog Input (AI), 3-183
 - Digital Inputs (DI), 3-182
 - USS on RS232, Receiving, 3-184
 - USS on RS232, Transmitting, 3-185
- Function diagrams Free Blocks
 - AND-, OR-, XOR- and NOT- Elements, 3-205
 - FlipFlops, 3-206
- Function diagrams General
 - Symbols in funktion diagrams, 3-177
- Function diagrams Internal Setpoint Source
 - Fixed Frequency (FF) Binary Selection (P1016 = 2), 3-189
 - Fixed Frequency (FF) Direct Selection (P1016 = 1), 3-188
 - Fixed PID setpoint, Binary Selection (P2216 = 2), 3-191
 - Fixed PID setpoint, Direct Selection (P2216 = 1), 3-190
 - Motor Potentiometer (MOP), 3-187
 - PID Motor Potentiometer (PID-MOP), 3-192

- Function diagrams Overview
 - Connection of External and Internal Set-points, 3-180
 - General Overview, 3-179
- Function diagrams Setpoint Channel
 - Additional Frequency Modifications, 3-210
 - PID Controller, 3-209
 - Ramp Function Generator, 3-211
 - Setpoint channel and Motor control, 3-208
- Function diagrams Technology Functions
 - Control word 1 (r0054), 3-199
 - Control word 2 (r0055), 3-200
 - Monitoring word 1 (r2197, bits 00 - 04), 3-194
 - Monitoring word 1 (r2197, bits 05 - 12), 3-195
 - Monitoring word 1 (r2197, bits 09 - 10), 3-196
 - Monitoring word 2 (r2198, bits 05 - 08), 3-197
 - Monitoring word 2 (r2198, bits 11 - 12), 3-198
 - Status word 1 (r0052), 3-201
 - Status word 2 (r0053), 3-202
 - Vdc_max control, 3-203
- Function diagrams V/f Control
 - Overview of V/f Control, 3-213

I

Index

- Parameters, 2-18
- Index (Parameters), 2-23
- Industrial security, 1-15

L

- Linked parameter, 2-18
- List of Abbreviations, B-235
- Lists

- Abbreviations, B-235
- ASCII-Table, A-233
- Binector Input Parameters, 2-166
- Binector Output Parameters, 2-167
- Command Data Sets, 2-161
- Connector Input Parameters, 2-167
- Connector Output Parameters, 2-168
- Connector/Binector Output Parameters, 2-169
- Drive Data Sets, 2-162
- Fault- and Alarm messages, 4-219
- Parameters all, 2-24
- Quick commissioning, 2-170

N

- Name
 - Parameters, 2-19
- Number
 - Parameters, 2-18

P

- Parameter lists
 - Binector Input Parameters, 2-166
 - Binector Output, 2-167
 - Command Data Sets, 2-161
 - Connector Input, 2-167
 - Connector Output, 2-168
 - Connector/Binector Output, 2-169
 - Drive Data Sets, 2-162
 - List of all Parameters, 2-24
 - Quick commissioning, 2-170

Parameters

- Bit field, 2-23
- Calculated, 2-21
- Can be changed, 2-22
- Data set, 2-22
- Data type, 2-20
- Dependency, 2-23
- Description, 2-23
- Index, 2-18, 2-23
- Linked parameter, 2-18
- Long name, 2-19
- Name, 2-19
- Number, 2-18
- Scaling, 2-21
- Short name, 2-19
- Text, 2-19
- Unit, 2-22
- Values, 2-23
- pxxxx, 2-18

R

- rxxxx, 2-18

S

- Safety instructions
 - Fundamental, 1-13
 - General, 1-14
 - Industrial security, 1-15
- Scaling (Parameters), 2-21

U

- Unit (Parameters), 2-22

V

- Values (Parameters), 2-23
- Visualization parameters, 2-18

Siemens AG
Digital Factory
Motion Control
P.O. Box 3180
91050 ERLANGEN
GERMANY

Subject to change
© Siemens AG 2016