

Industrial controls

Safety technology 3RQ1 force-guided coupling relays

Equipment Manual

Introduction	1
Safety instructions	2
Description	3
Safety systems - General information	4
3RQ1 devices	5
System configuration	6
Mounting	7
Connection	8
Configuration / operation	9
Commissioning	10
Display and diagnostics	11
Technical data	12
Dimension drawings	13
Circuit diagrams	14
Accessories	15

Legal information

Warning notice system

This manual contains notices you have to observe in order to ensure your personal safety, as well as to prevent damage to property. The notices referring to your personal safety are highlighted in the manual by a safety alert symbol, notices referring only to property damage have no safety alert symbol. These notices shown below are graded according to the degree of danger.

 DANGER
indicates that death or severe personal injury will result if proper precautions are not taken.

 WARNING
indicates that death or severe personal injury may result if proper precautions are not taken.

 CAUTION
indicates that minor personal injury can result if proper precautions are not taken.

NOTICE
indicates that property damage can result if proper precautions are not taken.

If more than one degree of danger is present, the warning notice representing the highest degree of danger will be used. A notice warning of injury to persons with a safety alert symbol may also include a warning relating to property damage.

Qualified Personnel

The product/system described in this documentation may be operated only by **personnel qualified** for the specific task in accordance with the relevant documentation, in particular its warning notices and safety instructions. Qualified persons are those who, because of their training and experience, are familiar with the installation, assembly, commissioning, operation, decommissioning and disassembly of the product and can recognize risks and avoid possible hazards.

Proper use of Siemens products

Note the following:

 WARNING
Siemens products may only be used for the application described in the catalog and the associated usage information. If products and components from other manufacturers are used, these must be recommended or approved by Siemens. Proper transport, storage, installation, assembly, commissioning, operation and maintenance are required to ensure that the products operate safely and without any problems. The permissible ambient conditions must be complied with. The information in the relevant documentation must be observed.

Trademarks

All names identified by ® are registered trademarks of Siemens Aktiengesellschaft. The remaining trademarks in this publication may be trademarks whose use by third parties for their own purposes could violate the rights of the owner.

Disclaimer of Liability

We have reviewed the contents of this publication to ensure consistency with the hardware and software described. Since variance cannot be precluded entirely, we cannot guarantee full consistency. However, the information in this publication is reviewed regularly and any necessary corrections are included in subsequent editions.

Table of contents

1	Introduction	7
1.1	Purpose of this manual	7
1.2	Target group	8
1.3	Required basic knowledge	9
1.4	Validity range	10
1.5	Siemens Industry Online Support	11
1.6	Siemens Industry Online Support app.....	13
1.7	DataMatrix code	14
1.8	ID link.....	15
1.9	Configurator for 3SK1 safety relays	17
1.10	User responsibility for system design and function.....	18
1.11	Additional documentation	19
1.12	Support Request	20
1.13	Change documentation	21
2	Safety instructions	23
2.1	General safety notes	23
2.2	Recycling and disposal	26
2.3	Intended use.....	27
2.4	Current information about operational safety	28
2.5	Cybersecurity information	29
2.6	Electromagnetic compatibility (EMC) according to IEC 60947-5-1	30
3	Description	31
3.1	Use.....	31
3.2	Product overview	32
4	Safety systems - General information	33
4.1	What is safety?	33
4.2	Safety function	34
4.3	Basic terminology	35
4.3.1	Redundancy/single-channel and two-channel	35
4.3.2	Cross-circuit detection.....	36
4.3.3	Enabling circuit (safety-related output).....	36
4.3.4	Signaling circuit	36
4.3.5	Feedback circuit.....	37

4.3.6	Stop category	37
4.3.7	Automatic start.....	38
4.3.8	Manual start	38
4.3.9	Monitored start.....	39
4.3.10	Two-hand operation/synchronism	39
4.3.11	Cascading	40
4.3.12	Startup testing.....	40
4.3.13	Connection of actuators	41
4.3.14	Series connection of sensors	44
4.3.15	Use of magnetically operated switches	45
5	3RQ1 devices	47
5.1	3RQ1 output expansion	47
5.1.1	Applications.....	47
5.1.2	Function description	48
5.1.3	Display of the operating state.....	48
5.1.4	Device features	49
5.1.5	3RQ11.00-.E.00, 3RQ1000-.G.00 configuration	50
5.1.6	3RQ1000-xHB00, 3RQ1000-xLB00 configuration	51
5.1.7	Terminal assignment.....	51
6	System configuration.....	53
6.1	3ZY12 device connector.....	53
6.1.1	Device features	53
6.1.2	Applications.....	56
6.2	System configuration rules	57
7	Mounting	61
7.1	Warning notices	61
7.2	Terminal coding	62
7.3	Mounting the devices on a level surface	63
7.4	Disassembling devices from a level surface	65
7.5	Mounting 22.5 mm/17.5 mm devices on a standard mounting rail	67
7.6	Mounting the 90 mm devices on a standard mounting rail	68
7.7	Removing devices from a standard mounting rail.....	69
7.8	Mounting 22.5 mm/17.5 mm devices with device connectors on a standard mounting rail	70
7.9	Removing 22.5 mm/17.5 mm devices with device connectors from a standard mounting rail.....	73
7.10	Mounting 90 mm devices with device connectors on a standard mounting rail	76
7.11	Removing 90 mm devices with device connectors from a standard mounting rail	79
7.12	Mounting 22.5 mm/17.5 mm devices with device connectors on the wall	82
7.13	Removing 22.5 mm/17.5 mm devices with device connectors from the wall	85
7.14	Mounting 90 mm devices with device connectors on the wall.....	87
7.15	Removing 90 mm devices with device connectors from wall	90

7.16	Mounting the sealable cover	92
8	Connection.....	93
8.1	Warning notices	93
8.2	22.5 mm/17.5 mm devices.....	94
8.2.1	Terminal assignment.....	94
8.2.2	Connection data for 3RQ1 screw terminal.....	95
8.2.3	Connecting the screw-type terminals	95
8.2.4	Disconnecting the screw-type terminals	96
8.2.5	Wiring rules for spring-loaded terminal (push-in system)	97
8.2.6	Connection data for 3SK1 spring-loaded terminal (push-in system).....	97
8.2.7	Connection data for 3RQ1 spring-loaded terminal (push-in system)	98
8.2.8	Connecting spring-loaded (push-in) terminals	98
8.2.9	Disconnect the spring-loaded (push-in) terminal.....	100
8.2.10	Attaching the terminals.....	100
8.2.11	Disconnecting.....	101
8.3	Devices 90 mm	104
8.3.1	Opening the terminal cover.....	104
8.3.2	Connection data for terminals	105
8.3.3	Connecting terminals.....	105
8.3.4	Mounting terminals	107
8.3.5	Disconnecting.....	108
8.4	Device replacement	110
9	Configuration / operation	113
9.1	Procedure for configuration.....	114
9.2	Explanation of the device's functions.....	115
9.3	Modes	118
9.4	Response times.....	119
10	Commissioning	121
11	Display and diagnostics	123
11.1	LED display	123
11.2	Power-up	125
11.3	Error statuses.....	126
11.4	Diagnostics	127
12	Technical data.....	129
12.1	Technical specifications in the Siemens SiePortal	129
12.2	Electrical endurance.....	130
12.3	Overview tables	132
13	Dimension drawings.....	133
13.1	CAX data in the Siemens SiePortal	133

14	Circuit diagrams	135
14.1	CAX data in the Siemens SiePortal	135
14.2	Internal circuit diagrams.....	136
14.2.1	Internal circuit diagrams for expansion units.....	136
14.3	Typical circuits	144
15	Accessories	157
15.1	Accessories for 3SK1	157

Introduction

1.1 Purpose of this manual

This manual contains a detailed description of the 3RQ1 force-guided coupling relays.

It provides you with the information you require to configure, install, connect, and diagnose 3RQ1 force-guided coupling relays. A few application examples provide you with a clear and practice-oriented introduction.

1.2 Target group

The manual is intended for everyone involved in the following tasks:

- Planning and configuring systems
- Installation
- Commissioning
- Service and maintenance

1.3 Required basic knowledge

A general knowledge of the following areas is needed in order to understand this manual:

- Low-voltage switchgear
- Digital circuit logic
- Automation systems
- Safety systems

1.4 Validity range

The equipment manual is valid for 3RQ1 force-guided coupling relays. It describes the components that are valid at the time of publication.

SIEMENS reserves the right of including a Product Information for each new component, and for each component of a later version.

1.5 Siemens Industry Online Support

Information and service

At Siemens Industry Online Support you can obtain up-to-date information from our global support database:

- Product support
- Application examples
- Forum
- mySupport

Link: Siemens Industry Online Support (<https://support.industry.siemens.com/cs/de/en>)

Product support

You can find information and comprehensive know-how covering all aspects of your product here:

- **FAQs**
Answers to frequently asked questions
- **Manuals/operating instructions**
Read online or download, available as PDF or individually configurable.
- **Certificates**
Clearly sorted according to approving authority, type and country.
- **Characteristics**
For support in planning and configuring your system.
- **Product announcements**
The latest information and news concerning our products.
- **Downloads**
Here you will find updates, service packs, HSPs and much more for your product.
- **Application examples**
Function blocks, background and system descriptions, performance statements, demonstration systems, and application examples, clearly explained and represented.
- **Technical data**
Technical product data for support in planning and implementing your project

Link: Product support (<https://support.industry.siemens.com/cs/ww/en/ps>)

mySupport

The following functions are available in your personal work area "mySupport":

- **Support Request**
Search for request number, product or subject
- **My filters**
With filters, you limit the content of the online support to different focal points.

- **My favorites**
With favorites you bookmark articles and products that you need frequently.
- **My notifications**
Your personal mailbox for exchanging information and managing your contacts. You can compile your own individual newsletter in the "Notifications" section.
- **My products**
With product lists you can virtually map your control cabinet, your system or your entire automation project.
- **My documentation**
Configure your individual documentation from different manuals.
- **CAX data**
Easy access to CAX data, e.g. 3D models, 2D dimension drawings, EPLAN macros, device circuit diagrams
- **My IBase registrations**
Register your Siemens products, systems and software.

1.6 Siemens Industry Online Support app

Siemens Industry Online Support app

The Siemens Industry Online Support app provides you access to all the device-specific information available on the Siemens Industry Online Support portal for a particular article number, such as operating instructions, manuals, data sheets, FAQs etc.

The Siemens Industry Online Support app is available for Android and iOS:



Android



iOS

1.7 DataMatrix code

A DataMatrix code is lasered onto the bottom terminal cover of all safety relays of the 3RQ1 device series.

DataMatrix codes are standardized in ISO/IEC 16022. The DataMatrix codes on Siemens devices use ECC200 coding for powerful error correction.

The following device information is encoded in the DataMatrix codes as a bit stream:

- Article number (MLFB)
- Serial number
- MAC address, if applicable

This information is stored in the following format in the DataMatrix code:

1P	Article number	+	S serial number
			(+ 23S MAC address)
Data identifier	Net content	Separator	

Note

The information content is displayed without spaces.

This machine-readable information simplifies and accelerates handling of the respective devices.

As well as fast access to the serial numbers of the respective devices for unique identification, the DataMatrix codes simplify communication with Siemens Technical Support.

1.8 ID link

ID link for the digital nameplate



The ID link is a globally unique identifier according to IEC 61406-1, which you can find as a QR code on your product. The ID link takes you to the digital nameplate of your product. Using the ID link saves paper and energy.

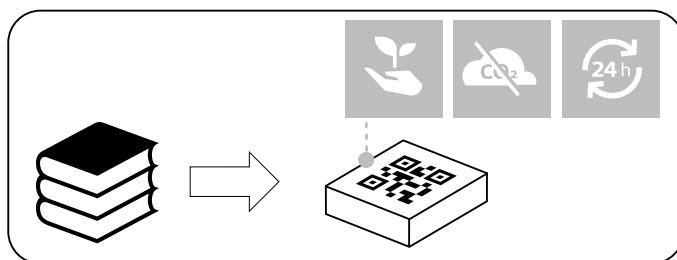

1.8 ID link

Scan the QR code on the product or on the packaging label with a smartphone camera, barcode scanner, or reader app. Call the ID-Link. In the digital nameplate, you will find product data, manuals, declarations of conformity, certificates, and other helpful information about your product.

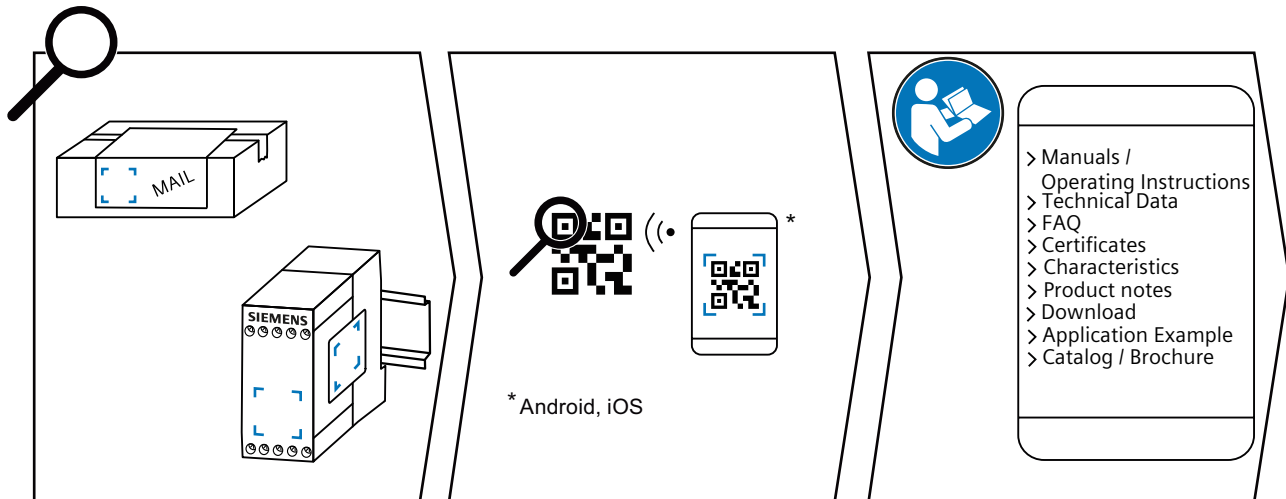

1.9 Configurator for 3SK1 safety relays

Configurator

Various configurators are available on the Internet to assist you with configuration.

The configurator for safety relays with accessories is an easy-to-use selection and engineering tool. You can select the individual components and plan your system in accordance with your specific requirements. You can save your selection, export it as a text file or you can order it directly.

The configurator automatically compiles a document list of the information available in Service & Support for every component. You can use it as the basis for putting together your system documentation.

Link:

Configurator (<https://mall.industry.siemens.com/mall/en/de/Catalog/Products/10027588?tree=CatalogTree&activetab=configurator>)

1.10 User responsibility for system design and function

The products described here were developed to perform safety-related functions as part of an overall installation or machine.

A complete, safety-related system is generally equipped with sensors, evaluation units, and signaling units, and uses reliable shutdown concepts.

It is the responsibility of the manufacturer of a system or machine to ensure that the product functions properly.

Siemens AG, its regional offices, and associated companies (hereinafter referred to as "Siemens") cannot guarantee all the properties of an entire plant, system or machine that has not been designed by Siemens.

Nor can Siemens assume liability for recommendations that appear or are implied in the following description. No new guarantee, warranty, or liability claims beyond the scope of the Siemens general terms of supply are to be derived or inferred from the following description.

1.11 Additional documentation

List of references

You will find further manuals in the table that may be of interest for your project planning. They are available to download from the Internet free of charge. You can create your own individual system documentation in the Siemens Industry Online Support under "mySupport".

Title of the manual	Document number
SIRIUS 3RK3 Modular Safety System	3ZX1012-0RK31-1AB1
SIRIUS 3SK1 Safety Relays	3ZX1012-0SK11-0AB0
SIRIUS 3SK2 Safety Relays	3ZX1012-0SK21-1AB1
SIRIUS 3RM1 motor starters	3ZX1012-ORM10-2AB1
SIRIUS Safety Integrated	3ZX1012-0SK11-1AB1

Interesting links

- Safety Evaluation Tool (<https://www.siemens.com/global/en/products/automation/topic-areas/safety-integrated/factory-automation/support/tia-safety-evaluation-tool.html>)
- Systematic industrial safety technology: Safety Integrated (<https://support.industry.siemens.com/cs/us/en/view/109747812>)

1.12 Support Request

Use the Support Request online form to send your question directly to Technical Support:

Support Request:	Internet (https://support.industry.siemens.com/My/ww/en/requests)
-------------------------	--

1.13 Change documentation

Product version	New features
10/2025	Initial release

Safety instructions

2.1 General safety notes

Note

SIL 3 acc. to IEC 62061 / PL e / Cat. 4 acc. to ISO 13849-1

The 3SK11 safety relays and SIRIUS 3RQ12 force-guided coupling relays are designed in such a way as to allow implementation of applications up to SIL 3 acc. to IEC 62061 and PL e / Cat. 4 acc. to ISO 13849-1.

Note

SIL 2 acc. to IEC 62061 / PL c / Cat. 2 according to ISO 13849-1 for 3RQ10 coupling relay

The 3RQ10 force-guided safety-related coupling relays are designed in such a way as to allow implementation of applications up to SIL 2 acc. to IEC 62061, PL c / Cat. 2 acc. to ISO 13849-1.

WARNING

Hazardous voltage.

Can cause death, serious injury, or property damage.

Hazardous electrical voltage can cause electric shock, burns, and damage to property.

- Turn off and lock out all power supplying the system and device before working on the device.
 - To ensure protection against the hazard of electric shock when the terminal cover is open, screw in all clamping screws that are not needed to clamp conductors.
 - Close the terminal covers and always keep them closed during operation.
-

WARNING

Loss of safety functions.

Can cause death, serious injury, or property damage.

3SK1, 3RQ1 output expansions and 3RM1 Failsafe motor starters that are connected to a 3SK2 safety relay via 3ZY12 device connectors are supplied with voltage via the device connectors.

Do not directly connect any separate supply voltage to an output expansion 3SK1 (A1/A2), 3RQ1 (A1/A2), or to a 3RM1 Failsafe (A1/A2) motor starter, as otherwise the safety function will be bypassed.

Note

Safe state

The basis of the safety function is the definition of the safe state. In the case of safety relays, this is the "OFF state", i.e. an open contact for sensors or shutdown of the actuators.

 **DANGER**

Hazardous voltage. Can cause death or serious injury

To ensure touch protection and degree of protection IP20, screw in all screws which are not used for conductor clamping and close the terminal covers.

 **WARNING**

Protection against electrically conductive contamination!

Can cause death, serious injury, or property damage.

The devices must be protected against conductive contamination while taking account of the ambient conditions. One way you can do this is to install the devices in a control cabinet with the appropriate degree of protection.

You will find more information in the IEC 60529 standard, "Degrees of protection provided by enclosures (IP Code)" and in the "Technical specifications (Page 129)" section.

 **WARNING**

Loss of safety function when adjusting slide switch on 3SK1 output expansions.

Can cause death, serious injury, or property damage.

- Use one of the optionally available cover sealings to protect the slide switch of the 3SK1 output expansion against unauthorized and unintentional adjustment.

 **WARNING**

Safe functional extra-low voltage

The 3SK1 safety relays, SIRIUS 3RQ1 force-guided coupling relays, and 3RM1 Failsafe motor starters with a supply voltage of 24 V DC must be operated with safe functional extra-low voltage (SELV, PELV). This means these modules must only be subjected to a voltage of U_m even in the event of a fault. **The following applies for these 3SK1 safety relays:** $U_m < 60.0$ V. You will find more detailed information about safe functional extra-low voltage in the data sheets of the power supplies to be used.

NOTICE

Material damage caused by electrostatic charging

When handling and installing 3SK1 safety relays, SIRIUS 3RQ1 force-guided coupling relays, and 3RM1 Failsafe motor starters, ensure that the components are protected from being electrostatically charged. Changes to the system configuration and wiring are only permissible while the supply voltage is switched off.

Connection of 3SK1 safety relays is only permissible when the power supply units (PELV and SELV) are switched off.

 **CAUTION****Noise immunity/grounding**

The following must be grounded in accordance with the regulations to ensure immunity of the 3SK1 safety relays, SIRIUS 3RQ1 force-guided coupling relays, and 3RM1 Failsafe motor starters with 24 V DC supply voltage:

- PELV / SELV power supply units
(please also note the documentation for the respective power supply unit in this regard).

2.2 Recycling and disposal

For environmentally friendly recycling and disposal of your old device, please contact a company certified for the disposal of old electrical and/or electronic devices and dispose of the device in accordance with the regulations in your country.

2.3 Intended use

 WARNING**Hazardous voltage****Proper use of hardware products**

This equipment is only allowed to be used for the applications described in the catalog and in the technical description, and only in conjunction with non-Siemens equipment and components recommended by Siemens.

Correct transport, storage, installation and assembly, as well as careful operation and maintenance, are required to ensure that the product operates safely and without faults.

EU note: Commissioning is absolutely prohibited until it has been ensured that the machine in which the component described here is to be installed complies with the stipulations of the Directive 2006/42/EC.

2.4 Current information about operational safety

Important note for maintaining operational safety of your system

 WARNING
Loss of safety functions due to obsolete information. Can cause death, serious injury, or property damage. Please take note of our latest information Systems with safety-related characteristics are subject to special operational safety requirements on the part of the operator. The supplier is also obliged to comply with special product monitoring measures. For this reason, we publish a special newsletter containing information on product developments and features that are (or could be) relevant to operation of safety-related systems. By subscribing to the appropriate newsletter, you will ensure that you are always up-to-date and able to make changes to your system, when necessary: For this purpose, go to the page: Safety Integrated for industrial safety technology (http://www.siemens.com/safety-integrated)

2.5 Cybersecurity information

Siemens provides products and solutions with industrial cybersecurity functions that support the secure operation of plants, systems, machines and networks.

In order to protect plants, systems, machines and networks against cyber threats, it is necessary to implement – and continuously maintain – a holistic, state-of-the-art industrial cybersecurity concept. Siemens' products and solutions constitute one element of such a concept.

Customers are responsible for preventing unauthorized access to their plants, systems, machines and networks. Such systems, machines and components should only be connected to an enterprise network or the internet if and to the extent such a connection is necessary and only when appropriate security measures (e.g. firewalls and/or network segmentation) are in place.

For additional information on industrial cybersecurity measures that may be implemented, please visit <https://www.siemens.com/cybersecurity-industry>.

Siemens' products and solutions undergo continuous development to make them more secure. Siemens strongly recommends that product updates are applied as soon as they are available and that the latest product versions are used. Use of product versions that are no longer supported, and failure to apply the latest updates may increase customer's exposure to cyber threats.

To stay informed about product updates, subscribe to the Siemens Industrial Cybersecurity RSS Feed under <https://new.siemens.com/cert>.

2.6 Electromagnetic compatibility (EMC) according to IEC 60947-5-1

This product is designed for Environment A. It may produce radio interference in domestic environments, in which case the user may be required to take adequate mitigation measures.

Description

3.1 Use

The areas of application for the SIRIUS 3RQ1 force-guided coupling relays primarily include safety-related applications, such as contact extensions for safety relays (e.g. SIRIUS 3SK), the safe coupling and transmission of control signals, an increase of switching capacity up to 10 A, and the electrical isolation of actuators and controllers in areas such as industrial automation, railway engineering, signal technology, and elevator systems. They enable the fail-safe execution of functions with certification up to SIL 3/PL e.

Applications

Depending on the version of the device and the external connection of sensors and actuators, applications up to SILCL 3 in accordance with IEC 62061, SIL 3 in accordance with IEC 61508, and PL e (Cat. 4) in accordance with ISO 13849-1 can be implemented.

- Monitoring the switch position of the sensors
- Monitoring of the sensor lines
- Monitoring the correct function of the safety relay
- Monitoring of the actuators
- Safety-related shutdown in case of hazards

3.2 Product overview

You can use the 3RQ1 force-guided coupling relays as an output expansion for 3SK1 units. You can achieve a safety level up to SIL 2 / PL c or SIL 3 / PL e (3RQ1) in accordance with IEC 62061 / EN ISO 13849 with this combination.

Expansion units

Designation	Voltages	Article number
3RQ1 force-guided coupling relays	24 V DC	3RQ1y00-xzB00
	24 ... 240 V AC/DC	3RQ1y00-xzW00

x = 1: Screw-type terminal; x = 2: Spring-loaded (push-in) terminal

x = 3: (3RM1 only) mixed connection system: Control circuit realized as spring-loaded (push-in) terminal and main circuit as screw terminal

y = 0: SIL 2 / PL c; y = 2: SIL 3 / PL e

z = E: 1NO 1NC; z = G: 2NO 1NC; z = H: 2NO 2NC; z = L: 4NO 1NC

Overview of the safety-related outputs

Type and number of safety-related outputs						
3RQ1 force-guided coupling relays						
3RQ1000-.E	1NO 1NC	-	-	-	-	✓ (for 24 V DC)
3RQ1200-.E (SIL 3 / PL e)						
3RQ1000-.G	2NO 1NC	-	-	-	-	✓ (for 24 V DC)
3RQ1000-.H	2NO 2NC	-	-	-	-	✓ (for 24 V DC)
3RQ1000-.L	4NO 1NC	-	-	-	-	✓ (for 24 V DC)

Safety systems - General information

4.1 What is safety?

Safety defines a state in which the risk of damage is reduced to a tolerable level, or which can be regarded as risk-free. Following on from this definition, functional safety concerns persons, machines and the environment.

The objective of safety systems is to reduce the risk for humans and machines that is posed by a use case to an acceptable level. The first step is, therefore, to identify the risk of a use case. In order to make a reliable assessment regarding the application, each individual function of a machine or plant must be analyzed for potential hazards.

For further information, refer to the brochure "Safety of machines and plants" which is available here as a download: Functional safety (<http://www.siemens.com/safety>).

4.2 Safety function

A safety function describes the reaction of a machine/plant when a specific event occurs (e.g. opening of a protective door). Execution of the safety function(s) is carried out by a safety-related control system. This usually comprises three subsystems, **detecting**, **evaluating** and reacting.

Detecting (sensors):

- Detecting a safety requirement, e. g.: EMERGENCY STOP or a sensor for monitoring a hazardous area (light array, laser scanner, etc.) is operated.

Evaluating (safety relay):

- Detecting a safety requirement and safely initiating the reaction (e.g. switching off the safety-related outputs).
- Monitoring the correct operation of sensors and actuators.
- Initiating a reaction upon detection of faults.

Reacting (actuators):

- Switching off the hazard by means of downstream actuators.

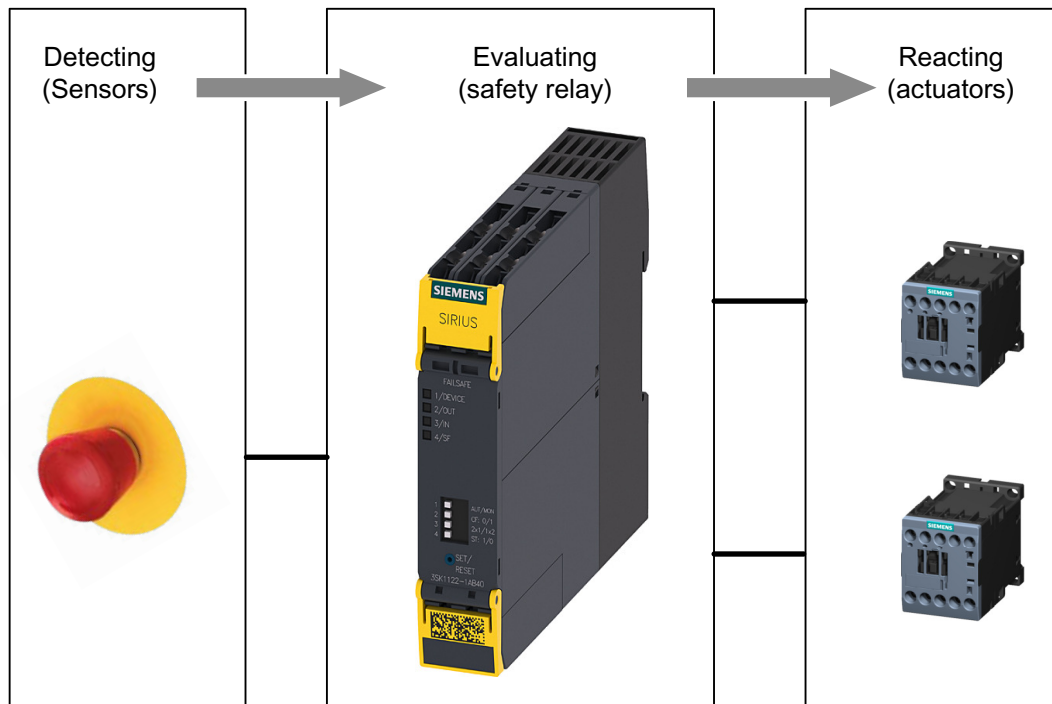

4.3 Basic terminology

4.3.1 Redundancy/single-channel and two-channel

Redundancy

With redundancy, more than one component is implemented for the same function, so a faulty function of a component is performed instead by the other component(s).

A redundant configuration reduces the probability of a function failing due to a single defective component. This requirement is essential for achieving SILCL 3 in accordance with IEC 62061, SIL 3 in accordance with IEC 61508 and PL e (Cat. 4) in accordance with ISO 13849-1 (also necessary for SIL 2 / PL d under certain circumstances).

The simplest form of redundancy is **two-channel redundancy**.

If a circuit fails, two-channel redundancy or appropriate wiring ensures that the safety function is maintained.

In a redundant system configuration, the subsystems for detecting and reacting must also be implemented with two-channel redundancy.

Note

All SIRIUS Safety devices that comply with SILCL 3 in accordance with IEC 62061, SIL 3 in accordance with IEC 61508 and PL e (Cat. 4) in accordance with DIN EN ISO 13849-1 are redundantly configured with regard to the internal logic as well as with regard to the output circuits.

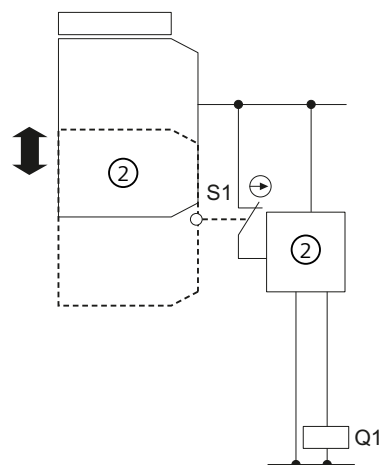

Figure 4-1 Single-channel sensor connection

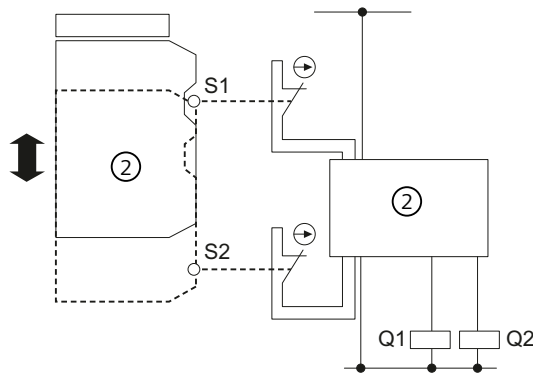

Figure 4-2 Two-channel sensor connection

* = positively-driven auxiliary contacts/mirror contacts

4.3.2 Cross-circuit detection

Cross-circuit detection is a diagnostic function of a safety relay that detects short-circuits and cross-circuits between the input channels (sensor circuits) during two-channel sensing or reading. A cross-circuit can be caused, for example, by a cable casing being squashed. In devices without cross-circuit detection, this can mean that a two-channel EMERGENCY STOP circuit does not trip even though only one NC contact is faulty (secondary error).

With 3SK1 devices, a cross-circuit is detected in the sensor circuits by means of signals with different clock pulses. If the clocked signals overlap, the device detects a cross-circuit. With 3SK1 basic units, cross-circuit detection can be deactivated to allow electronic sensors to be evaluated (that monitor themselves as well as the cable to the evaluation unit).

4.3.3 Enabling circuit (safety-related output)

An enabling circuit provides a safety-related output signal. From an external viewpoint, enabling circuits usually act as NO contacts (however, in terms of functionality, safety-oriented opening is always the most important aspect).

An individual enabling circuit that is redundantly configured internally in the safety relay can be used for SIL 3 / PL e.

Note: Enabling current paths can also be used for signaling purposes.

3SK1 safety relays are only equipped with enabling circuits with NO functionality. This means that when the safety function is triggered, or a fault is detected, the enabling circuits will always transfer to the safe state (NO contact open).

4.3.4 Signaling circuit

A current signaling path provides a safety-related output signal.

With 3SK1 relays, the signaling circuits are always implemented as NC circuits. This means that when the safety function is triggered, or a fault is detected, the signaling circuits will close.

With 3SK1 semiconductor devices, the signaling circuits are always implemented as NO circuits. This means that when the safety function is triggered, or a fault is detected, the signaling circuits will open.

4.3.5 Feedback circuit

A feedback circuit is used to monitor controlled actuators (e.g. relays or load contactors) with force-guided contacts or mirror contacts. The safety-related outputs can only be activated if the feedback circuit is closed.

Note

When 3SK1 output expansions are used on 3ZY12 device connectors with 3SK1 Advanced basic units, it is not necessary to incorporate the expansion modules in the feedback circuit wiring. This is implemented internally via the device connector.

DANGER

Ensuring electrical safety and safety function

The normally closed contact of 3RQ12. is designed for a voltage of 24 V DC. If higher voltages occur, electrical safety cannot be ensured due to the voltage clearance distances. If the 3RQ12. is integrated in a system with a device connector, the feedback circuit is routed via the device connector. Connection of external voltage is not necessary and not permitted. Connecting external voltage can bypass the safety function.

4.3.6 Stop category

Stop category 0

Non-controlled shutdown by immediately switching off the power to the machine's drive elements.

Stop category 1

Controlled stopping where the energy feed is interrupted with a time delay, or is only interrupted once standstill has been reached.

Note

Time-delayed shutdown of safety-related outputs in accordance with Stop category 1 is not ensured under all operating states.

In the case of some internal device faults, and when disconnecting the supply voltage, these safety-related outputs are switched off **instantaneously** .

4.3.7 Automatic start

For an automatic start, the device is started without manual confirmation, but only after the input image has been checked and a positive test of the safety relay has been conducted. This function is also known as dynamic operation and is not permissible for EMERGENCY STOP devices. Safety devices for prohibited danger zones (e.g. position switches, light arrays, safety shutdown mats) can use the automatic start function if this does not pose any risk.

Note

An automatic start is not permitted for EMERGENCY STOP devices.

4.3.8 Manual start

For a manual start, the device is started by operating the START button, but only after the input image has been checked and a positive test of the safety relay has been conducted. On a manual start, the START button is not monitored for correct operation, a positive edge of the START button is sufficient for starting.

Note

Manual start is not permitted for EMERGENCY STOP devices.

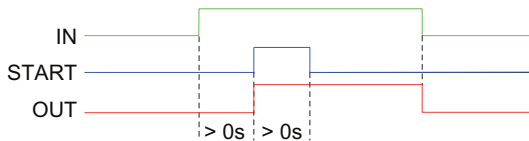

Figure 4-3 "Manual start" start function

4.3.9 Monitored start

For a monitored start, the device is started by operating the START button, but only after the input image has been checked and a positive test of the safety relay has been conducted.

Contrary to the manual start, the monitored start evaluates a **signal change** of the START button. This means that the START button cannot be bypassed (misuse). For PL e (ISO 13849-1) as well as SIL 3 (IEC 62061), the monitored start must be used in the case of EMERGENCY STOP. For other safety sensors/functions, the necessity for a monitored start command depends on the risk assessment.

If the START button is operated for more than 2 seconds, the 3SK1 basic unit detects a wiring short-circuit in the START button and switches to the fault state (Device = green; SF = flashing red; Out = flashing yellow; IN = off)

Note

In the delivery state of the 3SK1 safety relays, the start type is set to "Monitored start".

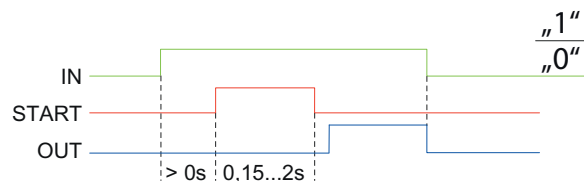

Figure 4-4 "Monitored start" start function

4.3.10 Two-hand operation/synchronism

Synchronous sensor operation is a special form of simultaneity of sensors.

In this case, it is not sufficient for sensor contacts 1 and 2 to be switched to the closed state "at any different times". Instead, they must be closed within 0.5 seconds.

Synchronism of sensors is required, in particular, in the case of two-hand operation of presses. This ensures that the presses only become active when the sensors are operated simultaneously with both hands. This minimizes the risk of the operator getting a hand in the press.

When 3SK1 safety relays are used, you can achieve applications up to type IIIc in compliance with EN 574 / EN 13851 (applications up to PL e/Cat. 4 in compliance with EN 13849-1 or SILCL 3 in compliance with IEC 62061).

Note

In the delivery state of 3SK1 safety relays, monitoring of time synchronism is deactivated. Monitoring of time synchronism can be activated using the following adjustable parameters for 3SK112 Advanced and 3SK122 Advanced:

- Jumper T1/PAR (NO/NC evaluation)
 - DIP switches (1) Autostart
 - DIP switches (3) 2 x single-channel
-

Note

The 3SK1 Advanced safety relays exclusively support two-hand control units with 2 NO contacts.

Note

The two-hand circuit must be marked in compliance with EN 574 EN 13851. You can find information on determining the response time in the section entitled Response times (Page 119).

4.3.11 Cascading

Cascading of safety relays is used for tripping safety relays in series.

Several safety functions can then be logically connected to a shared shutdown path. Several safety-related outputs can be created for selective shutdown of drive elements.

The connection between the individual modules must be arranged on one side only, because cascading from the last relay to the first one would create a loop which would prevent starting.

Cascading is implemented within a control cabinet in a single-channel configuration; this is even permissible with SIL 3 / PL e, because cable routing within a control cabinet is protected against short-circuits and short-circuiting to P potential (fault exclusion in accordance with ISO 13849-2).

The 3SK1 Advanced device series offers an extremely convenient solution for cascading. Input expansions can be easily connected to the evaluation unit by means of device connectors.

4.3.12 Startup testing

The sensor or protection equipment must be opened and closed again after the supply voltage is restored before the enables for the 3SK1 safety relay can be switched through.

Startup testing ensures that any errors in the sensors are detected (again), because safety relays lose their ability to store errors at zero voltage.

Unauthorized manipulation of the protection equipment can also be detected through startup testing.

The plant operator decides whether startup testing should be performed (risk assessment). No general statements apply.

Note

In the delivery state of 3SK1 safety relays, startup testing is deactivated.

4.3.13 Connection of actuators

Note

To achieve the Performance Level / Safety Integrity Level given in the following examples, the actuators shown must be monitored in the feedback circuit of the corresponding safety relay.

Note

For capacitive and inductive loads, we recommend an adequate protective circuit. In this way, electromagnetic interference can be suppressed and contact service life increased.

You can find more information in the SIRIUS Innovations - SIRIUS 3RT2 Contactors/Contactor Assemblies manual (<http://support.automation.siemens.com/WW/view/en/60306557>).

Actuator wiring up to PL c / Cat. 2 in accordance with ISO 13849-1 or SILCL 1 in accordance with IEC 62061

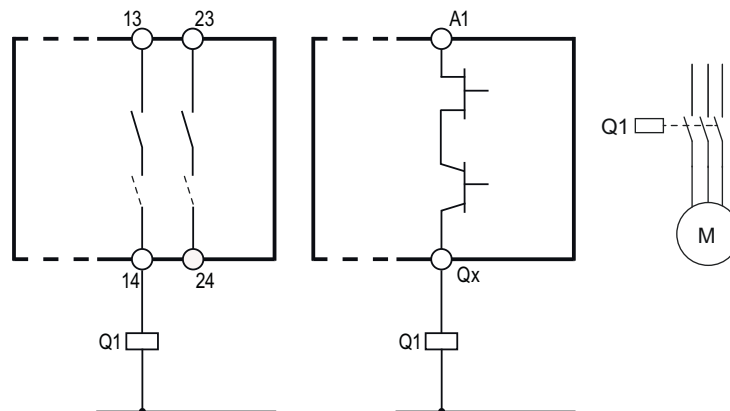

Figure 4-5 PL c / Cat. 2 in accordance with ISO 13849-1 or SILCL 1 in accordance with IEC 62061

Actuator wiring up to PL e / Cat. 4 in accordance with ISO 13849-1 or SILCL 3 in accordance with IEC 62061

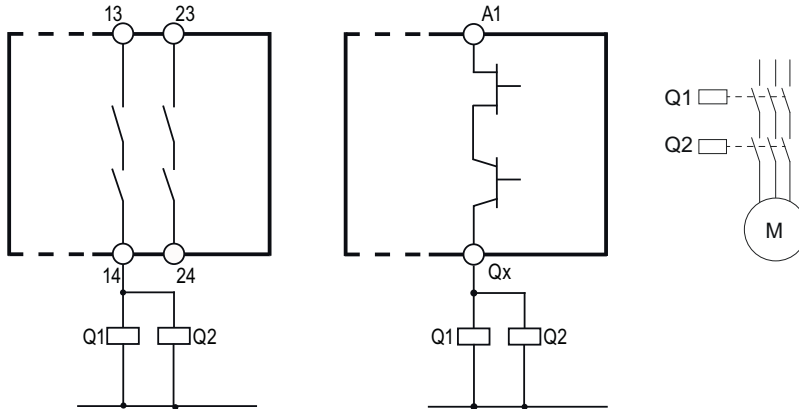

Figure 4-6 PL e/Cat. 4 in accordance with ISO 13849-1 or SILCL 3 in accordance with IEC 62061 With units that have semiconductor outputs, this wiring is only possible from E02/V1.1.0

⚠ WARNING
 PL e/Cat. 4 in accordance with ISO 13849-1 or SILCL 3 in accordance with IEC 62061 can only be achieved with cross-circuit-proof/short-circuit to P-proof laying of the control cables from the relay output (e.g. 14) to the control relays/contactors (Q1 and Q2) (e.g. as a separately sheathed cable or in its own cable duct).

Note
 In the case of 3SK1...2 and 3SK1120 (devices with semiconductor outputs with firmware (FW) version V1.0.0 and product version E01) it is not possible to achieve PL d/e/Cat. 3/4 in accordance with ISO 13849-1 or SILCL 2/3 in accordance with IEC 62061 with the wiring shown above.

Actuator wiring up to PL e / Cat. 4 in accordance with ISO 13849-1 or SILCL 3 in accordance with IEC 62061

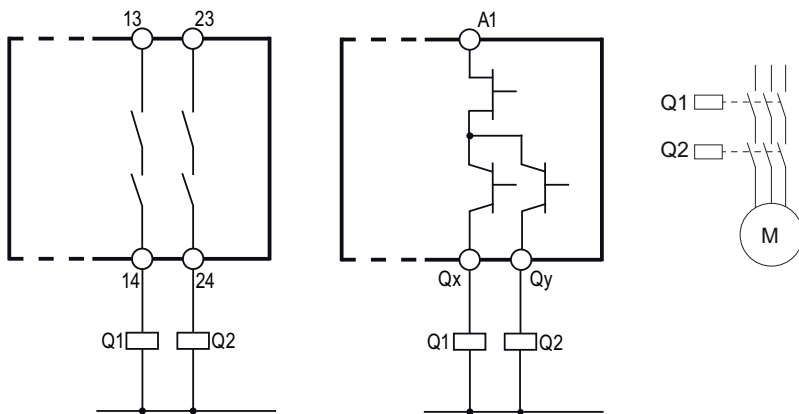

Figure 4-7 PL e / Cat. 4 in accordance with ISO 13849-1 or SILCL 3 in accordance with IEC 62061

Actuator wiring with 3RM1 up to PL e/Cat. 4 in accordance with ISO 13849-1 or SILCL 3 in accordance with IEC 62061

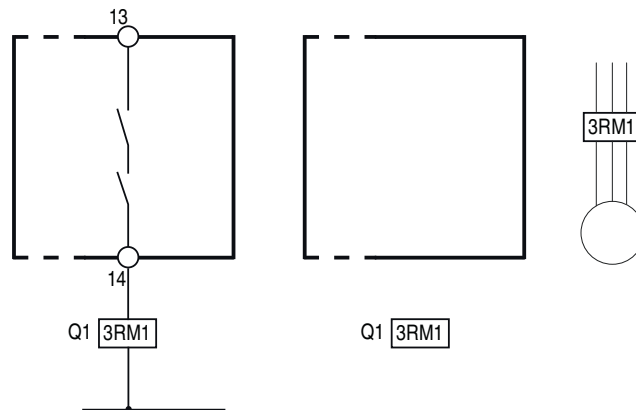

Figure 4-8 PL e / Cat. 4 in accordance with ISO 13849-1 or SILCL 3 in accordance with IEC 62061

Note

PL e/Cat. 4 in accordance with ISO 13849-1 or SILCL 3 in accordance with IEC 62061 can only be achieved with cross-circuit-proof/short-circuit to P-proof laying of the control cables from the relay output (e.g. 14) to the 3RM1 Failsafe motor starter (e.g. as a separately sheathed cable or in its own cable duct). Thanks to the intrinsic safety of the 3RM1 Failsafe motor starter, monitoring by the upstream 3SK1 safety relay (via feedback circuit) is not necessary here.

Note

In the case of 3SK1..2 and 3SK1120 (devices with semiconductor outputs with firmware (FW) version V1.0.0 and product version E01) it is not possible to achieve PL d/e/Cat. 3/4 in accordance with ISO 13849-1 or SILCL 2/3 in accordance with IEC 62061 with the wiring shown above.

More detailed technical information is available in the "SIRIUS 3RM1 motor starters (<http://support.automation.siemens.com/WW/view/en/66295730>)" manual on the Internet.

4.3.14 Series connection of sensors

Series connection of EMERGENCY STOP command devices

It is possible to connect EMERGENCY STOP command elements in series up to the highest safety level (SILCL3 in accordance with IEC 62061, SIL3 in accordance with IEC 61508, and PL e (Cat. 4) in accordance with ISO 13849-1) because it is assumed that only one EMERGENCY STOP is operated at a time. This ensures that errors and defects can be detected.

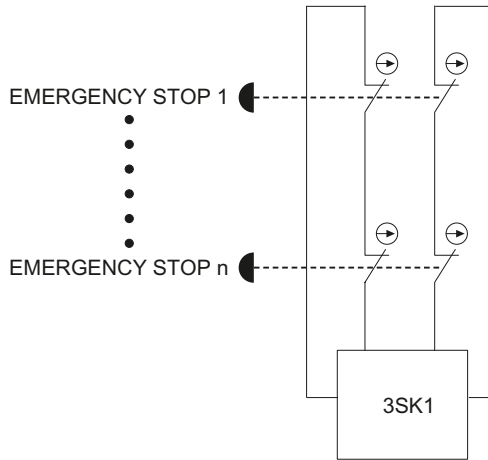

Series connection of mechanical position switches

In general, position switches may be connected in series if measures ensure that several protective doors are not regularly opened simultaneously (otherwise a fault cannot be detected).

For safety level SILCL3 in accordance with IEC 62061, SIL3 in accordance with IEC 61508, and PL e (Cat. 4) in accordance with ISO 13849-1, however, they must **never** be connected in series because every hazardous error must be detected (independently of the operating personnel).

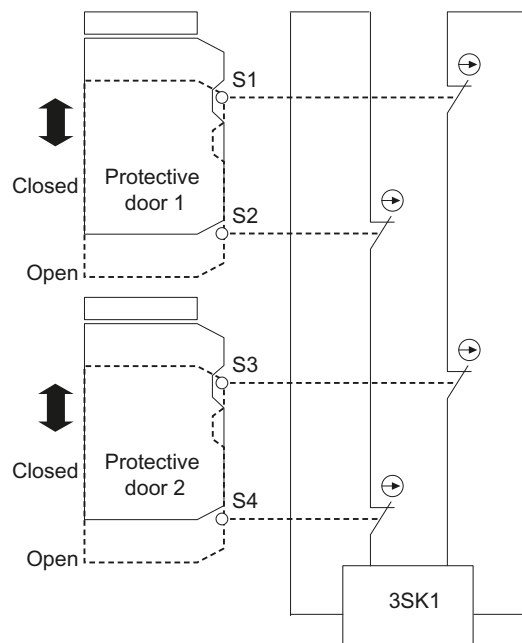

4.3.15 Use of magnetically operated switches

If magnetically operated switches are used, the magnetic contacts may weld on account of capacitive effects. The reason for this is that a high peak current may occur when switching these loads (e.g. also cable capacitances). A corresponding fuse protection with the rated current of the magnetically operated switch must be provided if the device/sensor combinations have not been explicitly enabled.

For more details, please refer to the documentation of the magnetically operated switch.

3RQ1 devices

5.1 3RQ1 output expansion

5.1.1 Applications

Expansion of safety-related outputs

The 3RQ1 output expansions are used to expand the safety-related outputs. The maximum achievable Performance Level PL/Cat. in accordance with ISO 13849-1, SILCL in accordance with IEC 62061, SIL in accordance with IEC 61508 is SIL 2 / PL; for 3RQ12. is SIL 3 / PL e. To achieve this, you must realize the external wiring, i.e. the connection between the basic unit and 3RQ1 output expansion, in a fail-safe manner, e.g. with the 3ZY12 device connector.

With the 3RQ10., SIL 2 in accordance with IEC 62061 can only be achieved by means of additional feedback circuit wiring of the 3RQ1 normally closed contact in the safety circuit of the 3SK1 basic unit.

The 3RQ12. output expansions are certified up to SIL 3 / PL e in accordance with IEC 62061 / ISO 13849. With these variants, the feedback circuit is situated on the device connector, that is to say, additional wiring of the feedback circuit is not necessary.

Note

If expansion units are controlled via the 3ZY12 device connector, additional feeding of the control supply voltage (A1/A2) at one of the output expansions leads to a fault in the system configuration.

Note

Using the output expansions with conventional wiring

If you require Stop category 1 outputs for the output expansion, terminals A1/A2 of the output expansion must be connected to outputs 38 or 48 on 3SK1 basic units with relay outputs or to Q1t/Q2t (in the case of 3SK1 with semiconductor outputs).

WARNING

Ensuring electrical safety and safety function

The normally closed contact of 3RQ12. is designed for a voltage of 24 V DC. If higher voltages occur, electrical safety cannot be ensured due to the voltage clearance distances. If the 3RQ12. is integrated in a system with a device connector, the feedback circuit is routed via the device connector. Connection of external voltage is not necessary and not permitted. Connecting external voltage can bypass the safety function.

Control

You can control the output expansions via the supply voltage (A1/A2).

Alternatively, with the 24 V AC/DC variant, you can control the output expansion via the 3ZY12 device connector.

If the expansion units are controlled via the 3ZY12 device connector, additional feeding of the control supply voltage (A1/A2) at one of the output expansions leads to a fault in the system configuration.

5.1.2 Function description

The operating state of the 3RQ1 output expansions is displayed on the DEVICE LED.

Depending on the variant used, the 3RQ1 output expansions have 1NO/1NC, 2NO/1NC, 2NO/2NC or 4NO/1NC. The output expansions can be controlled via any output of the basic unit via (A1). The NC circuits of the 3RQ1 are used to monitor the output expansion or for additional switching.

In the 24 V DC variants, the expansion units can be controlled and evaluated via the 3ZY12 device connectors.

5.1.3 Display of the operating state

Display of the operating state

The operating state and functioning of the device are indicated by an LED:

- (1) DEVICE

Operating states

LED	State	Meaning
DEVICE	Control supply voltage	Control state of the relay
Off	Off	Inactive position
Green	ON	Active position

5.1.4 Device features

Article number

Article number	Number of NO / NC contacts	Voltage supply	Width
3RQ1000-xEB00	1NO / 1NC	24 V DC	17.5 mm
3RQ1000-xEB00	1NO / 1NC	24 ... 240 V AC/DC	17.5 mm
3RQ1000-xGB00	2NO / 1NC	24 V DC	17.5 mm
3RQ1000-xGB00	2NO / 1NC	24 ... 240 V AC/DC	17.5 mm
3RQ1000-xHB00	2NO / 2NC	24 V DC	22.5 mm
3RQ1000-xHB00	2NO / 2NC	24 ... 240 V AC/DC	22.5 mm
3RQ1000-xLB00	4NO / 1NC	24 V DC	22.5 mm
3RQ1000-xLB00	4NO / 1NC	24 ... 240 V AC/DC	22.5 mm
3RQ1200-xEB00	1NO / 1NC	24 V DC	17.5 mm
3RQ1200-xEW00	1NO / 1NC	24 ... 240 V AC/DC	17.5 mm

x = 1: Screw-type terminal; x = 2: Spring-loaded (push-in) terminal

Power supply

24 V DC:

- An SELV / PELV power supply must be used for the infeed

24 ... 240 V AC/DC:

- Wide-range power supply for connecting a SELV / PELV power supply unit or a direct line supply connection L/N.

Device properties

- 1 LED for status display
- Up to 4 safety-related outputs (NO contacts)
- 1 NC circuit as feedback contact for output expansion to the up-circuit basic unit
- 3ZY12 device connectors.
- Enclosure widths 17.5 mm / 22.5 mm
- Removable terminals

5.1.5 3RQ11.00-.E.00, 3RQ1000-.G.00 configuration

Diagram showing a typical arrangement:

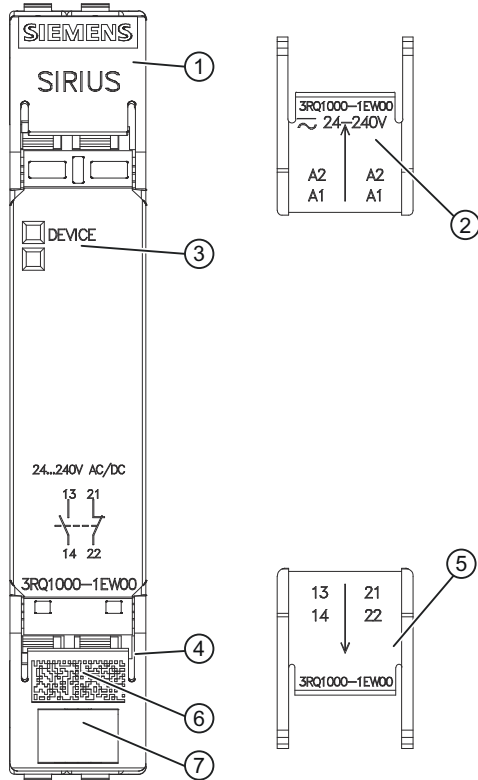

- ① Top cover flap
- ② Top cover flap; internal inscription
- ③ Display LEDs
- ④ Bottom cover flap
- ⑤ Bottom cover flap; internal inscription
- ⑥ DataMatrix code
- ⑦ Device identification label

5.1.6 3RQ1000-xHB00, 3RQ1000-xLB00 configuration

Diagram showing a typical arrangement:

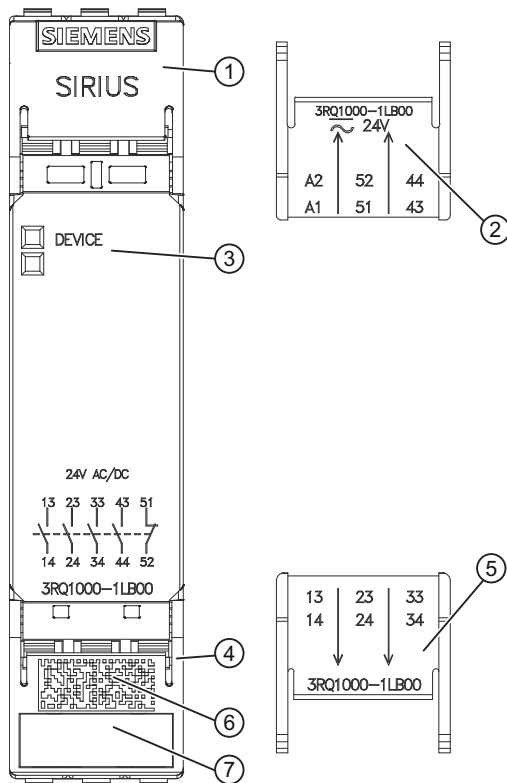

- ① Top cover flap
- ② Top cover flap; internal inscription
- ③ Display LEDs
- ④ Bottom cover flap
- ⑤ Bottom cover flap; internal inscription
- ⑥ DataMatrix code
- ⑦ Device identification label

5.1.7 Terminal assignment

3RQ100-.E.00 / 3RQ1200-.E.00

Terminal	Explanation
A1	+
A2	-
13 - 14	Safety-related output 1 (NO contact, relay contact)
21 - 22	NC circuit as feedback contact (NC, relay contact)

3RQ1000-.GB00

Terminal	Explanation
A1	+
A2	-
13 - 14	Safety-related output 1 (NO contact, relay contact)
23 - 24	Safety-related output 2 (NO contact, relay contact)
31 - 32	NC circuit as feedback contact (NC, relay contact)

3RQ1000-.HB00

Terminal	Explanation
A1	+
A2	-
13 - 14	Safety-related output 1 (NO contact, relay contact)
23 - 24	Safety-related output 2 (NO contact, relay contact)
31 - 32	NC circuit as feedback contact (NC, relay contact)
41 - 42	NC circuit as feedback contact (NC, relay contact)

3RQ1000-.LB00

Terminal	Explanation
A1	+
A2	-
13 - 14	Safety-related output 1 (NO contact, relay contact)
23 - 24	Safety-related output 2 (NO contact, relay contact)
33 - 34	Safety-related output 3 (NO contact, relay contact)
43 - 44	Safety-related output 4 (NO contact, relay contact)
51 - 52	NC circuit as feedback contact (NC, relay contact)

System configuration

6.1 3ZY12 device connector

6.1.1 Device features

Article number:

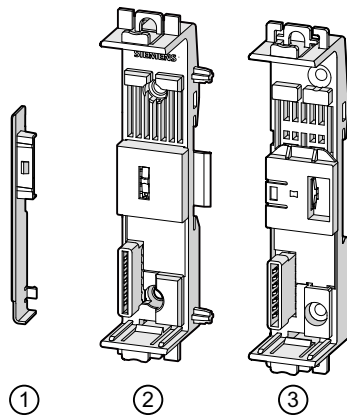

- ① Cover (included in the scope of supply of each device termination connector.)
- ② 3ZY12 device connectors
- ③ 3ZY12 device termination connectors

Article number	Device connector for
3ZY1212-1BA00	3SK1 safety relay 3SK1 / 3RQ1 output expansion Width 17.5 mm
3ZY1212-2BA00	3SK1 safety relay 3SK1 / 3RQ1 output expansion Width 22.5 mm
3ZY1212-2EA00	3RM1 motor starter Width 22.5 mm
3ZY1212-2AB00	Device connector for looping through signals Width 22.5 mm
3ZY1210-2AA00	Device connector without function Width 22.5 mm

Article number	Device termination connector for
3ZY1212-2FA00	3RM1 motor starter Width 22.5 mm
3ZY1212-2DA00	3SK1 safety relay 3SK1 / 3RQ1 output expansion Width 22.5 mm
3ZY1212-1DA00	3RQ1 output expansion Width 17.5 mm
3ZY1212-0FA01	Set for 3SK1 safety relay, > 45 mm wide Set consists of 3ZY1212-2FA00 device connector and 3ZY1210-2AA00 device connector

Use of device connectors

- A device connector is always necessary when other devices have to be plugged in.
- A device termination connector is always required in the system for the last module on the right.

Note

Use of the device connectors to expand the Advanced basic units is optional.

The device connectors cannot be used with the Standard series.

Note

Only safety relays with a supply voltage of **24 V DC** may be used on the 3ZY12 device connectors.

Note

If expansion units are controlled via the 3ZY12 device connector, additional feeding of the control supply voltage (A1/A2) at one of the output expansions leads to a fault in the system configuration.

⚠ DANGER

Ensuring electrical safety and safety function

The normally closed contact of 3RQ12. is designed for a voltage of 24 V DC. If higher voltages occur, electrical safety cannot be ensured due to the voltage clearance distances. If the 3RQ12. is integrated in a system with a device connector, the feedback circuit is routed via the device connector. Connection of external voltage is not necessary and not permitted. Connecting external voltage can bypass the safety function.

The following device connectors are required for the various enclosure widths of the Advanced device series:

Devices	Device connector for 3SK1 safety relay 17.5 mm 3ZY1212-1BA00	Device connector for 3SK1 safety relay 22.5 mm 3ZY1212-2BA00	Device termination connector for 3SK1 safety relay 22.5 mm 3ZY1212-2DA00	Device termination connector for 3RQ1 17.5 mm 3ZY1212-1DA00
3SK1 Advanced basic units				
3SK1121	-	x	x	-
3SK1122	-	x	x	-
3SK1120	x	-	-	-
Output expansions 3SK1				
3SK1211 (4RO)	-	x	x	-
3SK1213 (3RO)	-	-	-	-
3RQ1 force-guided coupling relays				
3RQ1*E/G* (17.5 mm)	x	-	-	x
3RQ1*H/L* (22.5 mm)	-	x	x	-
Input expansions 3SK1				
3SK1220	x	-	-	-
3SK1230 power supply	-	x	-	-
3RM1 Failsafe motor starters				
3RM1	-	-	-	-

Devices	Device connector for 3RM1 motor starter 22.5 mm 3ZY1212-2EA00	Device termination connector for 3RM1 motor starter 22.5 mm 3ZY1212-2FA00	Device termination connector set for enclosures > 45 mm ¹⁾ 3ZY1212-0FA01	Device connector for looping through signals 22.5 mm 3ZY1212-2AB00
3SK1 Advanced basic units				
3SK1121	-	-	-	-
3SK1122	-	-	-	-
3SK1120	-	-	-	-
Output expansions 3SK1				
3SK1211 (4RO)	-	-	-	-
3SK1213 (3RO)	-	-	x	-
3RQ1 force-guided coupling relays				
3RQ1*E/G* (17.5 mm)	-	-	-	-
3RQ1*H/L* (22.5 mm)	-	-	-	-
Input expansions 3SK1				
3SK1220	-	-	-	-

6.1 3ZY12 device connector

Devices	Device connector for 3RM1 motor starter 22.5 mm 3ZY1212-2EA00	Device termination connector for 3RM1 motor starter 22.5 mm 3ZY1212-2FA00	Device termination connector set for enclosures > 45 mm ¹⁾ 3ZY1212-0FA01	Device connector for looping through signals 22.5 mm 3ZY1212-2AB00
3SK1230 power supply	-	-	-	-
3RM1 Failsafe motor starters				
3RM1	x	x	-	x

¹⁾ Set consists of 3ZY1212-2FA00 device connector and 3ZY1210-2AA00 device connector

Note

If a basic unit is expanded on the right, the last output expansion must be terminated with a device termination connector of the corresponding device.

If a basic unit is only expanded on the left, a device termination connector for 3SK1 safety relays must be mounted below the basic unit.

6.1.2 Applications

The 3SK1 Advanced basic unit can be expanded on the input and output sides using 3ZY12 device connectors (connecting plugs) without any additional wiring outlay. When configuring the system, it is important to ensure that input expansions are connected on the left and 3RQ1 force-guided coupling relays/3RM1 Failsafe motor starters on the right of a basic unit.

6.2 System configuration rules

General information

- All basic units can be operated as a stand-alone device without a device connector.

Expansion on the input side

- If an (additional) input expansion is detected on the left when the basic device or an input expansion powers up, it will be loaded into the device configuration.
- An input expansion evaluates the sensor states and generates an enable signal for the basic unit depending on the start condition. The enable signal is then acquired by an input expansion on the right-hand side, or acquired by the basic unit and ANDed with its sensor statuses.
You can find information on the start characteristics in the system configuration of the 3SK1 Advanced in the chapter "Explanation of the device's function (Page 115)".
- The 3ZY12 device connector used below the final device must be fitted with a cover on the left side (included with the device termination connectors).
- A 3SK1230 power supply can also be used in the 3SK system. This 3SK1230 power supply must always be plugged into the system on the extreme left.
- No more than one 3SK1230 power supply is admissible for each system.
- If a 3SK1230 power supply is used, **no** additional, external 24 V DC voltage is permitted to be connected to a basic unit.

Output expansion

- If an output expansion is detected on the right when the device powers up, this will be loaded into the device configuration. The internal feedback circuit of the contact extension is evaluated and checked.
- If both the 3SK1211 / 3RQ1 output expansion and 3RM1 Failsafe motor starters are used in a system, the 3RM1 Failsafe motor starters must be positioned on the right of the 3SK1211 / 3RQ1 output expansions.
- If a 3SK1213 output expansion is used in the system, this must always be the final station in the system (on the right) and must be fitted with a 3ZY1212-0FA01 device termination connector. Only one 3SK1213 output expansion can be used in the system with a device connector; further 3SK1213 output expansions can be optionally interfaced by wiring.
- On the 3SK121 output expansions, a slide switch on the device front must be used to set whether the (UNDELAYED) or (DELAYED) output signal of the basic unit is to trigger a response. If a purely instantaneous 3SK112 basic unit is used, the slide switch **MUST** be set to the (UNDELAYED) position.
The 3RQ1 output expansions do not have a slide switch and always react to the (UNDELAYED) output signal.
- In the case of a change to the device configuration during operation, error mode is activated immediately. Restarting must be triggered via Power OFF/ON.

6.2 System configuration rules

- If output expansions are used, a device termination connector for the 3SK1 safety relay must ALWAYS be used under the final device on the right (for 3SK1211) with the switch setting: "1" (switch in top position), device termination connector set for 3SK1 safety relay, > 45 mm wide (for 3SK1213) or device termination connectors for 3RM1 motor starters must be used
- 22.5 mm device termination connector for 3SK1 / 3RQ1:

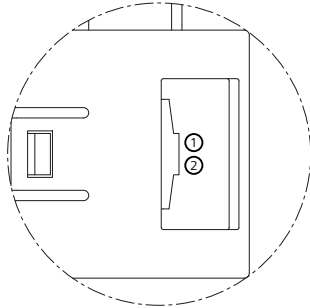

- ① Below 3SK1211 output expansion: The switch of the device termination connector must be closed, i.e. in position 1 at the top
- ② Below basic unit: The switch of the device termination connector must be open, i.e. in position 2 at the bottom.

- No switch needs to be set on the device termination connector for 3RM1 motor starters
- As from certain load limits/temperature ranges, clearances must be observed for 3RM1 Failsafe motor starters. To this end, there are appropriate device connectors for looping through signals (3ZY1212-2AB00).
- In the configuration with a 3SK1 Advanced basic unit on a 3ZY12 device connector, 3RM1 Failsafe motor starters can only be controlled by the instantaneous enable signal of the 3SK1 unit. If control of the 3RM1 Failsafe motor starters by means of the time-delayed output is desired, this can only be done by wiring the time-delayed safety-related output of the 3SK1 basic unit.

You will find further information on the configuration guidelines for 3RM1 Failsafe motor starters in the SIRIUS 3RM1 motor starters (<http://support.automation.siemens.com/WW/view/en/66295730>) manual, in the chapter "Load feeders - protection against short circuit".

Configuration notes for using device connectors

Further configuration notes:

 WARNING
Ensuring electrical safety and safety function
The normally closed contact of 3RQ12. is designed for a voltage of 24 V DC. If higher voltages occur, electrical safety cannot be ensured due to the voltage clearance distances. If the 3RQ12. is integrated in a system with a device connector, the feedback circuit is routed via the device connector; connection of external voltage is not necessary and not permitted. Connecting external voltage can bypass the safety function.

⚠ WARNING**Supply voltage must only be fed in on the basic unit**

The supply voltage of 24 V DC must only be fed in on the basic unit, otherwise the safety function is bypassed.

Note

If expansion units are controlled via the 3ZY12 device connector, additional feeding of the control supply voltage (A1/A2) at one of the output expansions leads to a fault in the system configuration.

Power supply by means of the 3SK1230 power supply

- When device connectors are used, only one 3SK1230 power supply is permitted in each system.
- The 3SK1230 power supply must always be located on the extreme left.
- If a 3SK1230 power supply is used, an additional (external) 24 V DC connection is not permitted (this also applies to the cascading input, as well as to non-floating sensors).

24 V DC supply voltage from an external power supply unit

- It is only permitted to connect a voltage of 24 V DC to the terminals on the basic unit.
- It is not permitted to supply 24 V DC to an expansion component or 3RM1 Failsafe motor starter.

Mounting

7.1 Warning notices

 WARNING
Hazardous Voltage Can Cause Death, Serious Injury, or Property Damage. Hazardous electrical voltages can cause electric shock, burns and damage. <ul style="list-style-type: none">• Turn off and lock out all power supplying the system and device before working on the device.• To ensure protection against the hazard of electric shock when the terminal cover is open, screw in all terminal screws that are not needed to clamp conductors.• Close the terminal covers and always keep them closed during operation.

 DANGER
Hazardous voltage. Can cause death or serious injury To ensure touch protection and degree of protection IP20, screw in all screws which are not used for conductor clamping and close the terminal covers.

7.2 Terminal coding

You can provide the terminals with coding pins (3ZY1440-1AA00). This helps you to avoid errors when replacing the terminals.

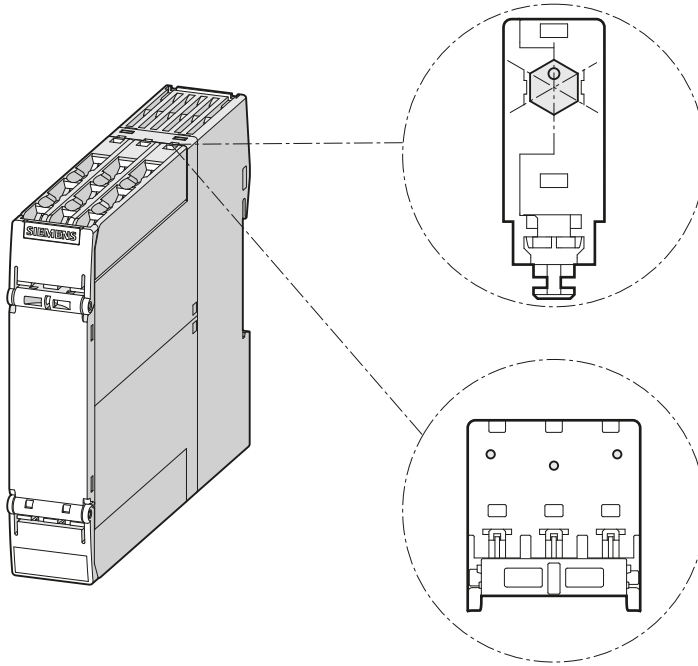

Figure 7-1 Module with coding pins

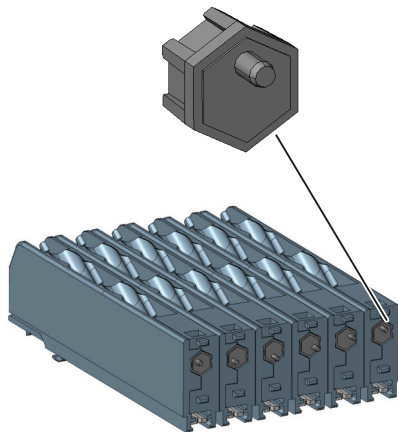

Figure 7-2 Stud position rotated by 60° in each case

7.3 Mounting the devices on a level surface

Requirements

Please note the following requirements for mounting on a level surface:

- Mounting position: Any (except 3SK1213). With 3SK1213: +/- 22.5° lateral inclination.
- Clearances: The distance to be maintained to the side with side-by-side mounting is 0 mm. The distance to be maintained to the side from grounded parts is 5 mm.
- Properly executed drill holes with thread or plug on the level surface. For details of the distances between the drilled holes, refer to the relevant dimension drawings (Page 133).
- Two headed screws for 17.5 mm or 22.5 mm devices / four headed screws for 90 mm devices to fit the holes M4 x 12 in accordance with DIN 784.
- Plastic push-in lugs: Refer to the accessories list for the relevant article number in the chapter "Accessories (Page 157)".

Procedure

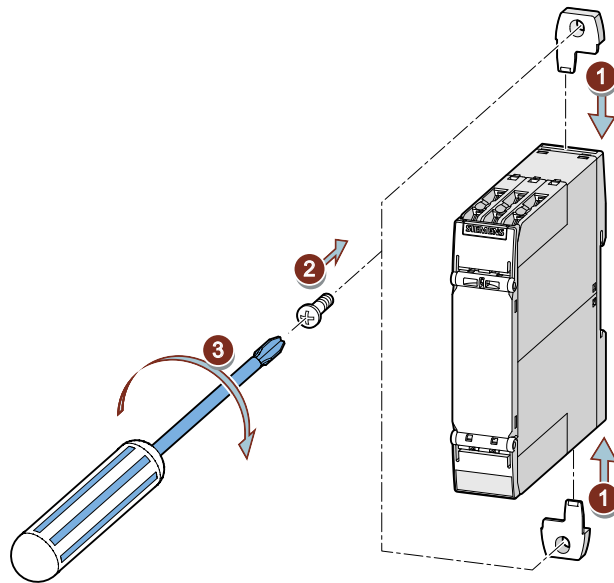

Figure 7-3 17.5 mm and 22.5 mm devices

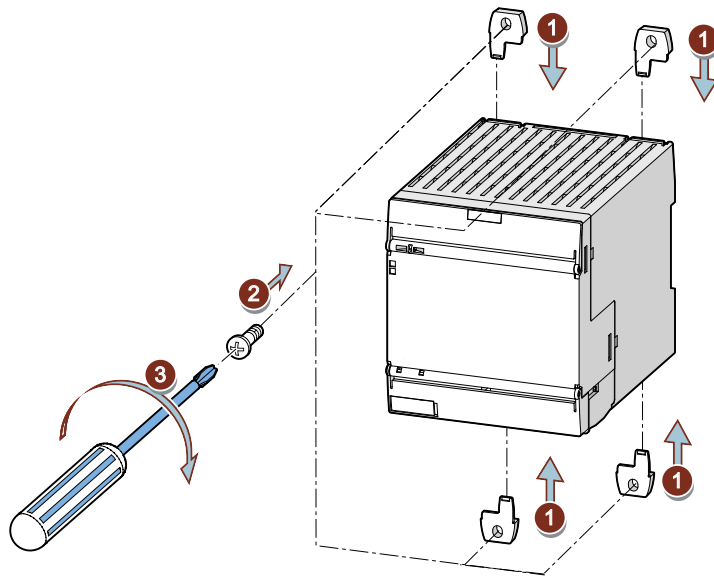

Figure 7-4 90 mm device

1. Insert the push-in lugs into the openings provided on the device until they engage.
2. Hold the device up to the surface prepared for screw fastening.
3. Insert the screws through the elongated holes into the push-in lugs.
4. Screw the device onto the level surface so that it is secure.

Tightening torque: 1 Nm

7.4 Disassembling devices from a level surface

⚠ WARNING**Hazardous voltage**

Can Cause Death, Serious Injury, or Property Damage.

Before starting work, therefore, disconnect the system and devices from the power supply.

Requirements

- The terminals have been removed or disconnected.

Procedure

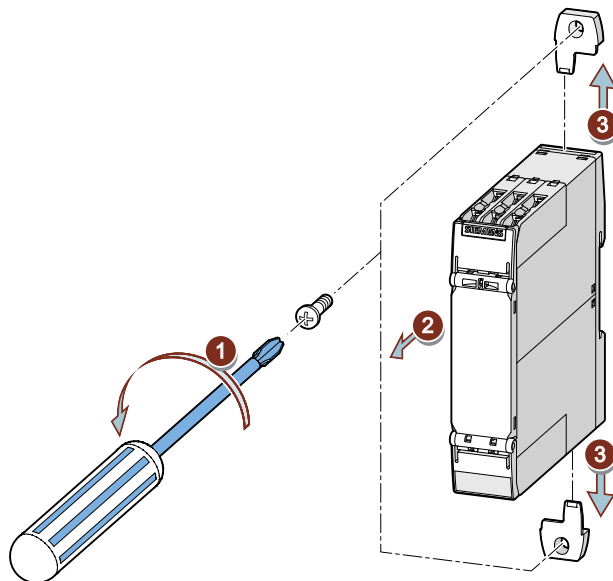

Figure 7-5 Disassembling 17.5 mm and 22.5 mm devices

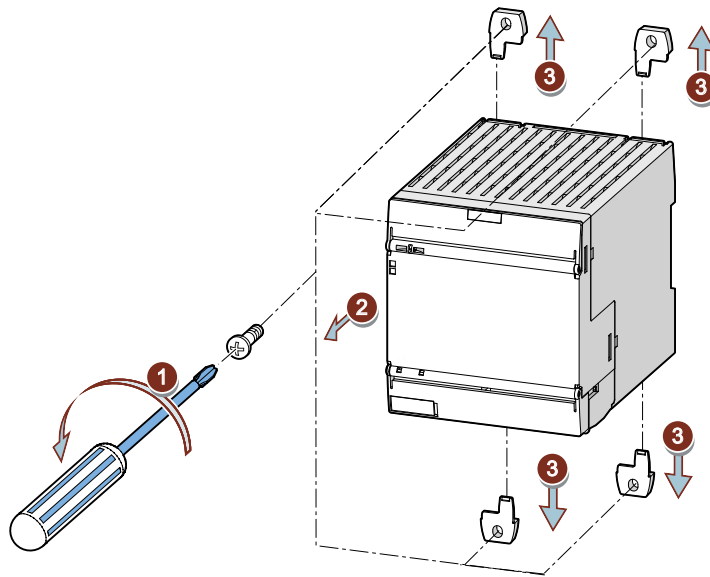

Figure 7-6 Disassembling 90 mm devices

1. Hold the device firmly.
2. Unscrew the cap screws.
3. Lift the device from the level surface.
4. Remove the push-in lugs from the device.

7.5 Mounting 22.5 mm/17.5 mm devices on a standard mounting rail

Requirements

- A horizontal 35 mm wide mounting rail in accordance with DIN EN 60715 has been properly secured at the installation location.
- Clearances: The distance to be maintained to the side with side-by-side mounting is 0 mm. The distance to be maintained to the side from grounded parts is 5 mm.
- Please observe the information about the mounting position in the technical data (Page 129).

Procedure

The figures show 22.5 mm devices. The 17.5 mm devices are mounted correspondingly.

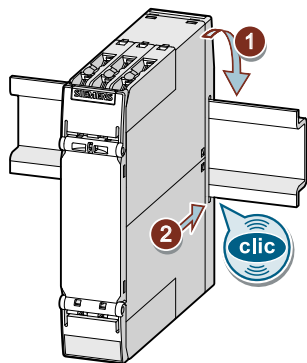
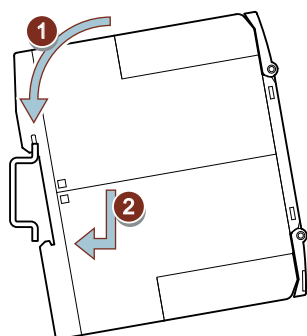

1. Place the back of the device onto the upper edge of the standard mounting rail.
2. Press the lower half of the device against the DIN rail until the device engages.

7.6 Mounting the 90 mm devices on a standard mounting rail

Requirements

- A horizontal 35 mm wide mounting rail in accordance with DIN EN 60715 has been properly secured at the installation location.
- Clearances: The distance to be maintained to the side with side-by-side mounting is 0 mm. The distance to be maintained to the side from grounded parts is 5 mm.
- Please observe the information about the mounting position in the technical data (Page 129).

Procedure

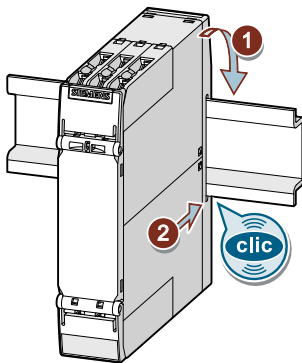
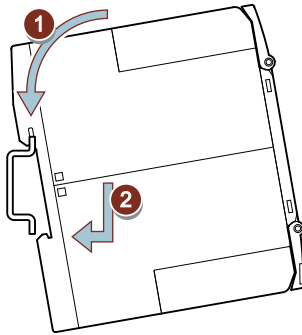

1. Place the back of the device onto the upper edge of the standard mounting rail.
2. Press the lower half of the device against the DIN rail until the device engages.

7.7 Removing devices from a standard mounting rail

⚠ WARNING

Hazardous Voltage
Can Cause Death, Serious Injury, or Property Damage.

Before starting work, therefore, disconnect the system and devices from the power supply.

Requirements

- The terminals have been removed or disconnected.

Procedure

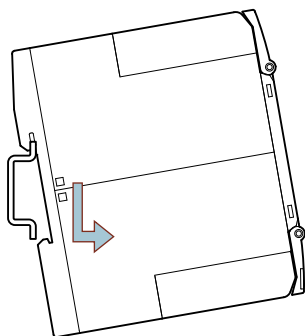

1. Press the device downwards.
2. Pull the lower half of the device away from the standard mounting rail.
3. Lift the device from the upper edge of the standard mounting rail.

7.8 Mounting 22.5 mm/17.5 mm devices with device connectors on a standard mounting rail

Requirements

- A horizontal 35 mm wide mounting rail in accordance with DIN EN 60715 has been properly secured at the installation location.
- Clearances: The distance to be maintained to the side with side-by-side mounting is 0 mm. The distance to be maintained to the side from grounded parts is 5 mm.
- Please observe the information about the mounting position in the technical data (Page 129).
- Device connectors:
Refer to the accessories list for the relevant article number in the chapter "Accessories (Page 157)".

Procedure

The figures show 22.5 mm devices. The 17.5 mm devices are mounted correspondingly.

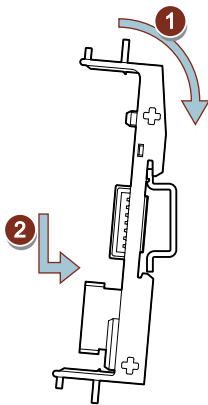

1. Place the back of the device connector on the upper edge of the standard mounting rail.
2. Press the lower half of the device connector against the standard mounting rail until the connector engages. Repeat the procedure with all the required device connectors.

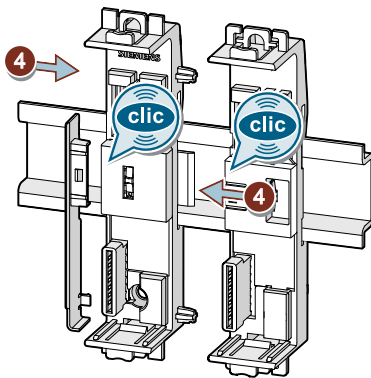

7.8 Mounting 22.5 mm/17.5 mm devices with device connectors on a standard mounting rail

4. Push the device connectors together until they engage.
5. Mount the cover on the left of the first device connector. The cover is included in the scope of supply of the device termination connector.

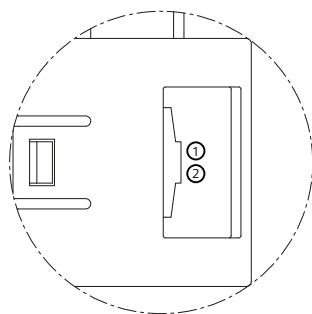
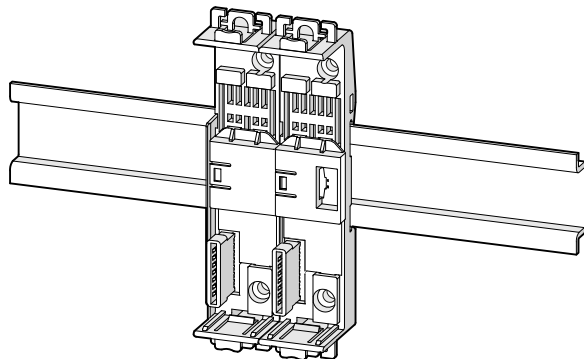

6. Set the slide switch in the device termination connector for the 3SK1 safety relay to the following positions:
 - Below 3SK1211 output expansion
Position ① (top; i.e. closed)
 - Below 3SK1 basic device
Position ② (bottom; i.e. open)

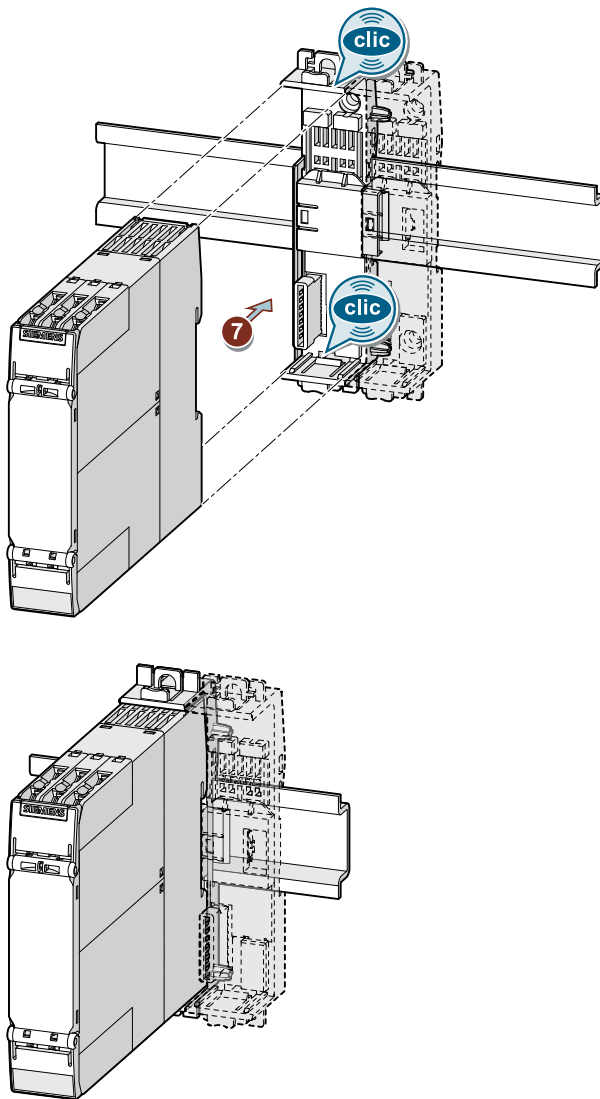

7. Mount the device on the device connector.
8. Mount all the devices required for the system configuration in accordance with the respective installation guidelines on the device connectors.

7.9 Removing 22.5 mm/17.5 mm devices with device connectors from a standard mounting rail

WARNING

Hazardous Voltage

Can Cause Death, Serious Injury, or Property Damage.

Before starting work, therefore, disconnect the system and devices from the power supply.

Requirements

- The terminals have been removed or disconnected.

Procedure

The figures show 22.5 mm devices. The 17.5 mm devices are removed correspondingly.

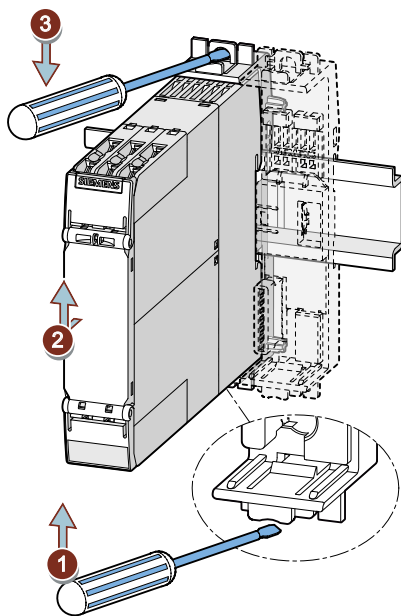

1. Unlock the device using a screwdriver.
2. Pull the lower half of the device away from the device connector.
3. Unlock the device using a screwdriver.

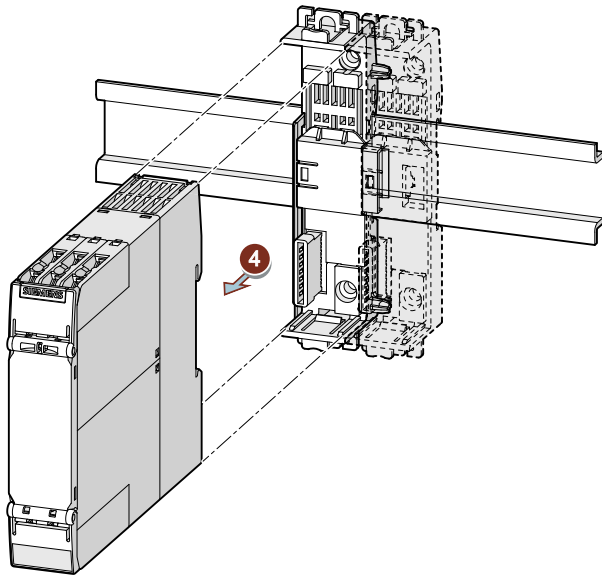

4. Pull the device away from the device connector.

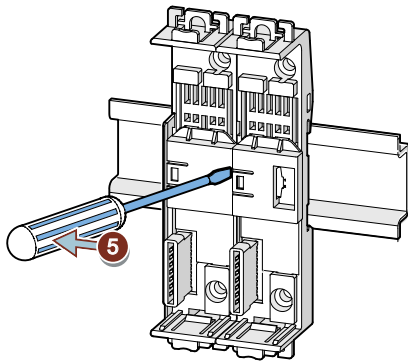

5. Separate the device connectors using a screwdriver.

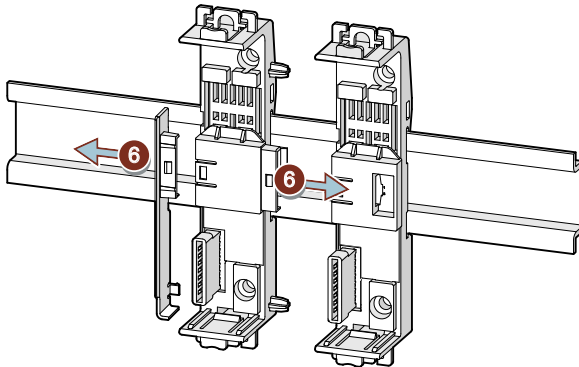

6. Remove the cover.

7.9 Removing 22.5 mm/17.5 mm devices with device connectors from a standard mounting rail

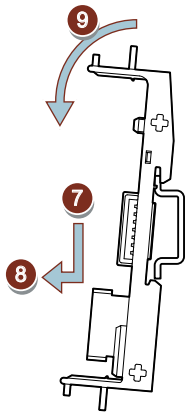

7. Press the device connector down.
8. Pull the lower half of the device connector away from the standard mounting rail.
9. Lift the device connector from the upper edge of the standard mounting rail.

7.10 Mounting 90 mm devices with device connectors on a standard mounting rail

Requirements

- A horizontal 35 mm wide mounting rail in accordance with DIN EN 60715 has been properly secured at the installation location.
- Clearances: The distance to be maintained to the side with side-by-side mounting is 0 mm. The distance to be maintained to the side from grounded parts is 5 mm.
- Please observe the information about the mounting position in the technical data (Page 129).
- Use the device termination connector set for 3SK1 safety relays, > 45 mm wide. Refer to the accessories list for the relevant article number in the chapter "Accessories (Page 157)".
- Please observe the obligatory mounting rules in the chapter: "System configuration rules (Page 57)".

Procedure

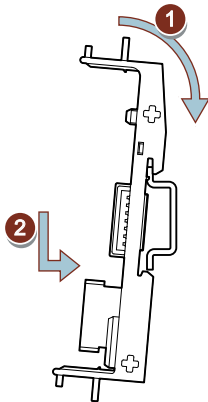

1. Hang the back of the device connector onto the upper edge of the standard mounting rail.
2. Press the lower half of the device connector against the standard mounting rail until the connector engages.
3. Repeat the procedure with all the required device connectors.

7.10 Mounting 90 mm devices with device connectors on a standard mounting rail

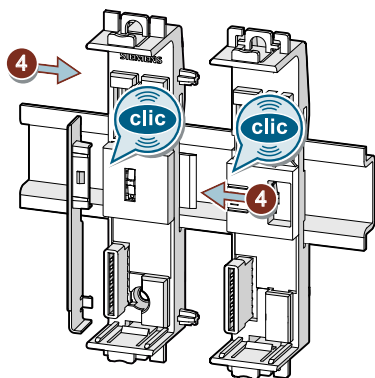

4. Push the device connectors together until they engage.

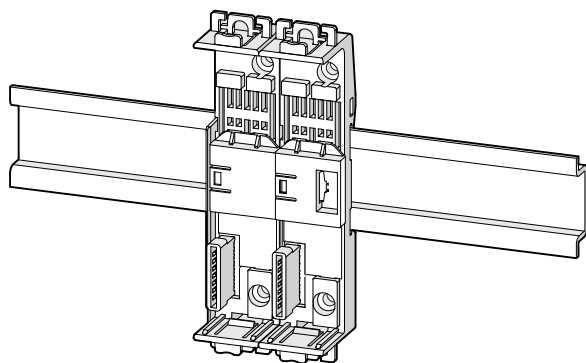

5. Mount the cover on the left of the first device connector piece and the device connectors supplied in the set for enclosures of 45 mm upwards (right-hand side).

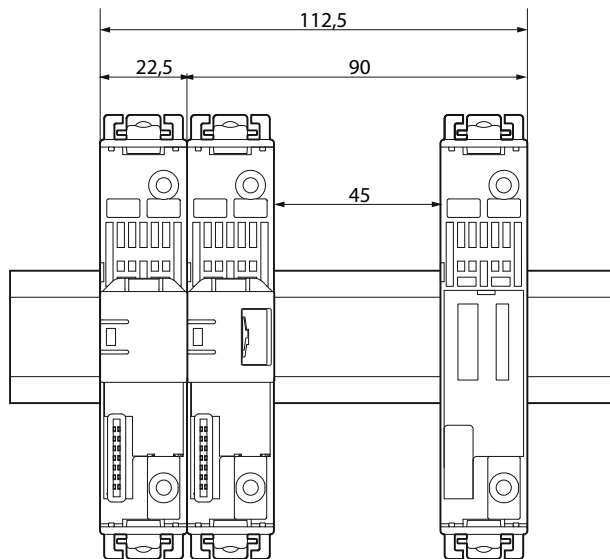

6. Note the clearances required for the 90 mm devices.

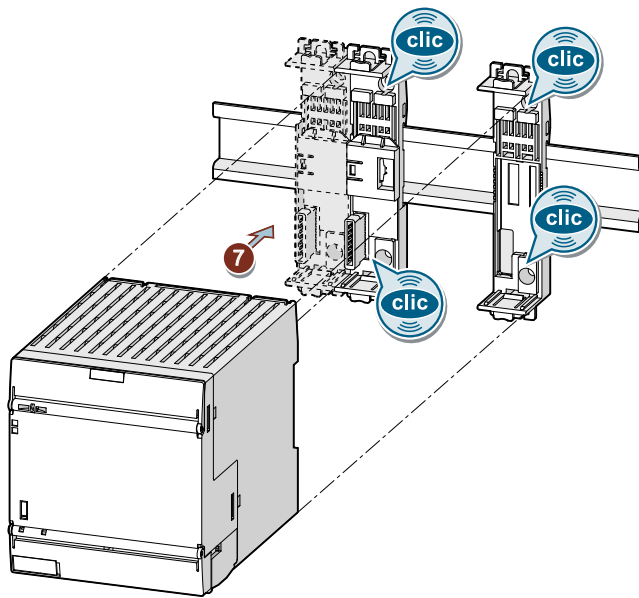

7. Mount the 3SK1213 output expansion on the device connectors.

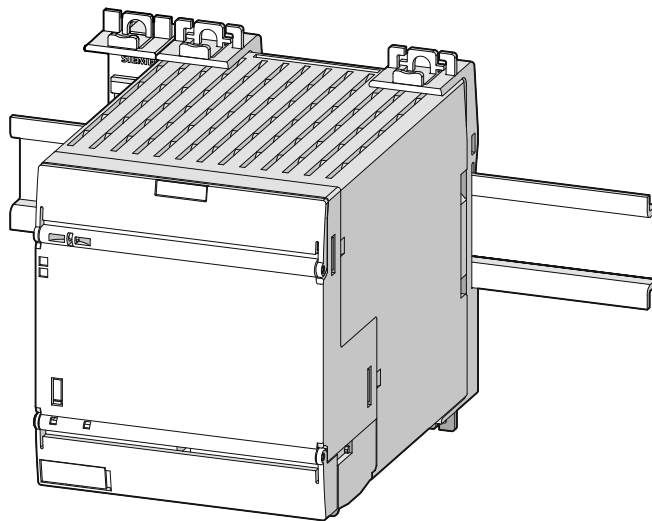

8. Mount all the devices required for the system configuration on the device connectors in accordance with the respective installation guidelines.

7.11 Removing 90 mm devices with device connectors from a standard mounting rail

⚠ WARNING

Hazardous Voltage

Can Cause Death, Serious Injury, or Property Damage.

Before starting work, therefore, disconnect the system and devices from the power supply.

Requirements

- The terminals have been removed or disconnected.

Procedure

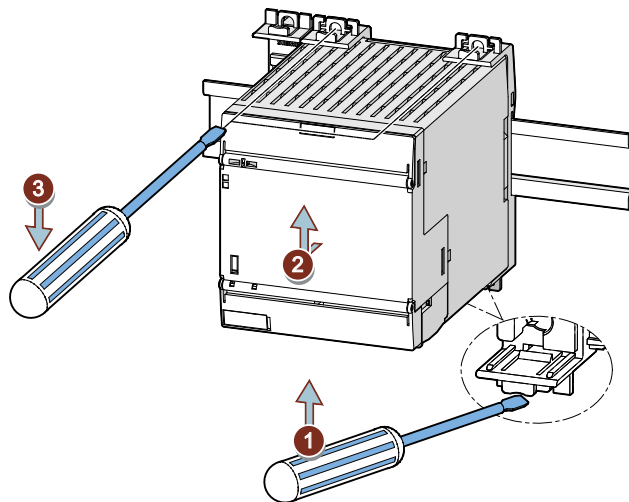

1. Unlock the device using a screwdriver.
2. Pull the lower half of the device away from the device connector.
3. Unlock the device using a screwdriver.

7.11 Removing 90 mm devices with device connectors from a standard mounting rail

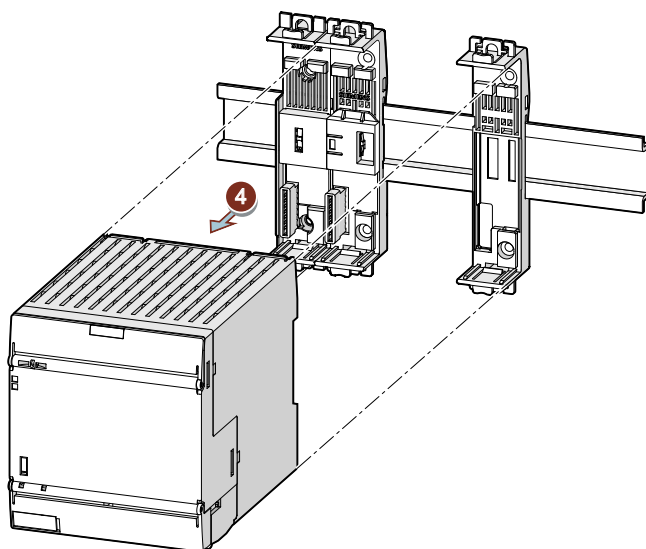

4. Pull the device away from the device connector.

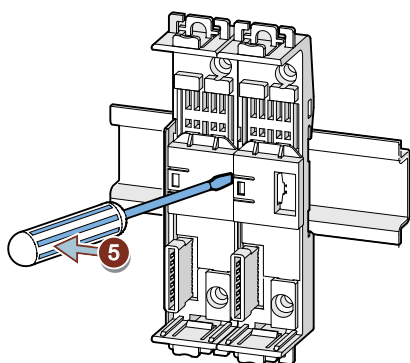

5. Separate the device connectors using a screwdriver.

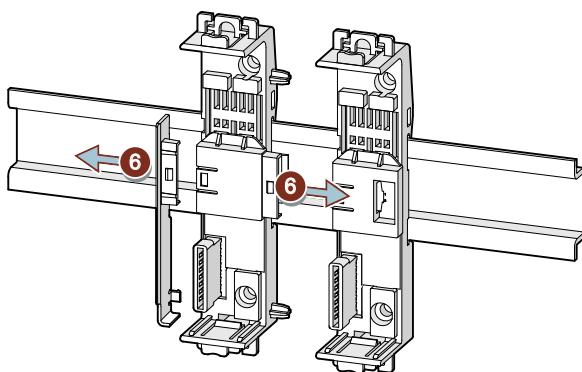

6. Disassemble the terminating section.

7.11 Removing 90 mm devices with device connectors from a standard mounting rail

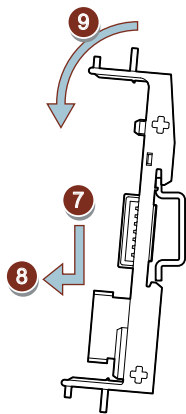

7. Press the device connector down.
8. Pull the lower half of the device connector away from the standard mounting rail.
9. Lift the device connector from the upper edge of the standard mounting rail.

7.12 Mounting 22.5 mm/17.5 mm devices with device connectors on the wall

Requirements

Please note the following requirements for mounting on a level surface:

- Please observe the information about the mounting position in the technical data (Page 129).
- Clearances: The distance to be maintained to the side with side-by-side mounting is 0 mm. The distance to be maintained to the side from grounded parts is 5 mm.
- Two properly executed drill holes (per device connector) with thread or plug on the level surface.
- Two screws (per device connector) to fit the holes M4 x12 in accordance with DIN 784.
- Device connector
Refer to the accessories list for the relevant article number in the chapter "Accessories (Page 157)".

Procedure for mounting on a level surface

The figures show 22.5 mm devices. The 17.5 mm devices are mounted correspondingly.

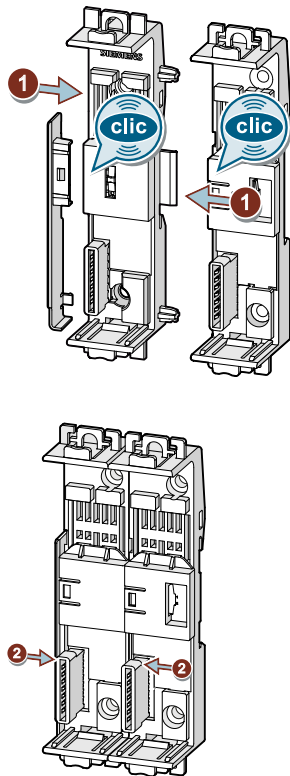

7.12 Mounting 22.5 mm/17.5 mm devices with device connectors on the wall

Push the device connectors together until they engage.

1. Mount the cover on the left of the first device connector. The cover is included in the scope of supply of the device termination connector.
2. Set the slide switch in the device termination connector for the 3SK1 safety relays to the following positions:
 - Below 3SK1211 output expansion
Position ① (top; i.e. closed)
 - Below 3SK1 basic device
Position ② (bottom; i.e. open)

(not applicable when mounting 3RM1 Failsafe motor starters)

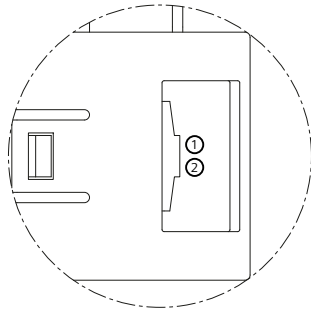

3. Hold the device connector against the level surface prepared for screw fastening.

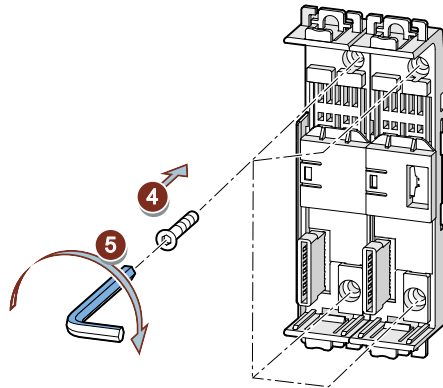

4. Insert the screws through the holes in the device connectors.

5. Screw the device connector securely onto the level surface.
Tightening torques:
 - Top: < 0.1 Nm
 - Bottom: 1 Nm

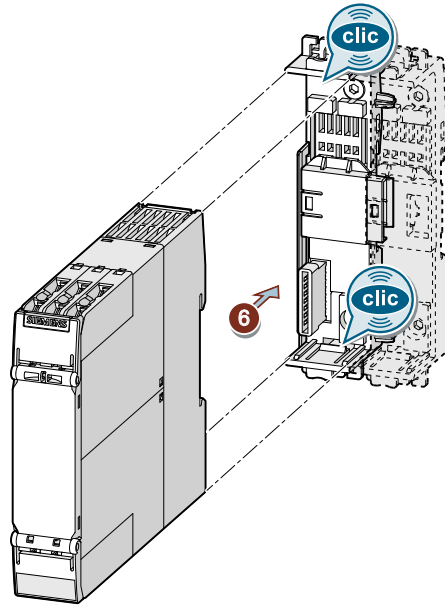

6. Mount the device on the device connector.

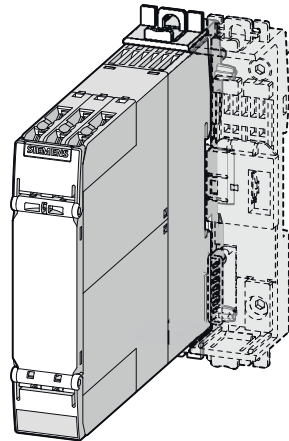

7. Mount all the devices required for the system configuration in accordance with the respective installation guidelines on the device connectors.

7.13 Removing 22.5 mm/17.5 mm devices with device connectors from the wall

WARNING

Hazardous Voltage

Can Cause Death, Serious Injury, or Property Damage.

Before starting work, therefore, disconnect the system and devices from the power supply.

Requirements

- The terminals have been removed or disconnected.

Procedure

The figures show 22.5 mm devices. The 17.5 mm devices are removed correspondingly.

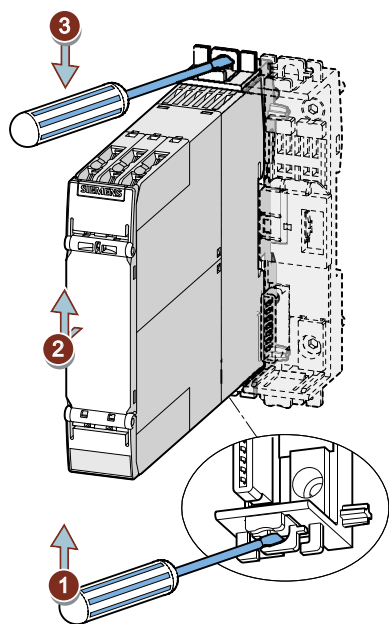

1. Unlock the device (below) using a screwdriver.
2. Pull the lower half of the device away from the device connector.

3. Unlock the device (above) using a screwdriver.

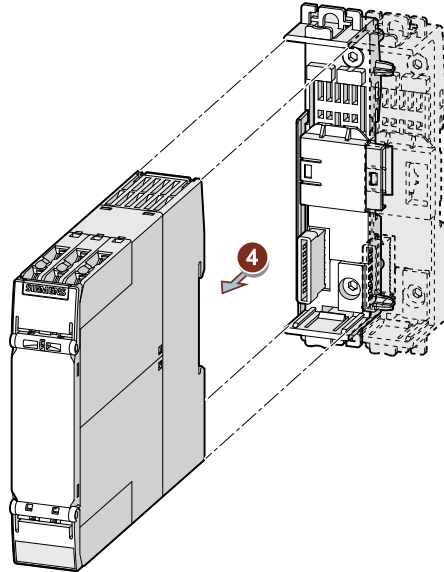

4. Pull the device away from the device connector.

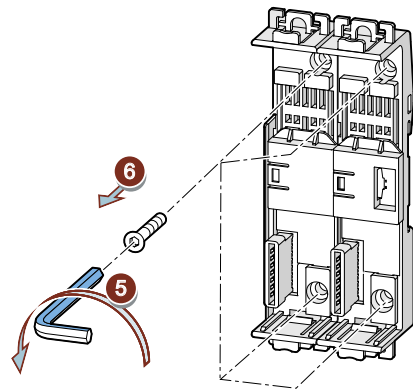

5. Release the screws.
6. Separate the device connectors.

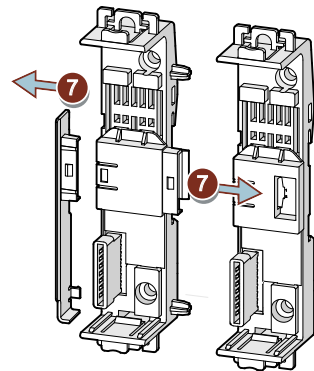

7. Remove the cover.

7.14 Mounting 90 mm devices with device connectors on the wall

Requirements

Please note the following requirements for mounting on a level surface:

- Please observe the information about the mounting position in the technical data (Page 129).
- Clearances: The distance to be maintained to the side with side-by-side mounting is 0 mm. The distance to be maintained to the side from grounded parts is 5 mm.
- Two properly executed drill holes with thread or plug on the level surface (per device connector).
- Two M4 x 12 screws in accordance with DIN 784 (per device connector) to fit the holes.
- Use the device termination connector set for 3SK1 safety relays, > 45 mm wide. Refer to the accessories list for the relevant article number in the chapter "Accessories (Page 157)".

Procedure

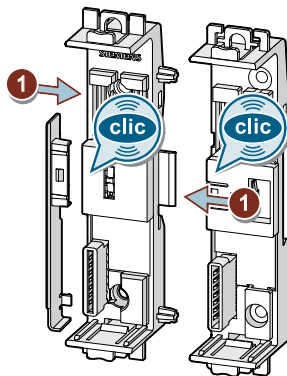

7.14 Mounting 90 mm devices with device connectors on the wall

1. Push the device connectors together until they engage.

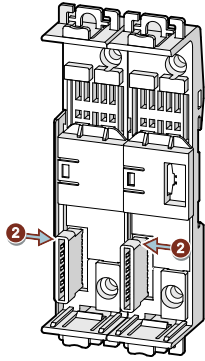

2. Mount the cover on the left of the first device connector.

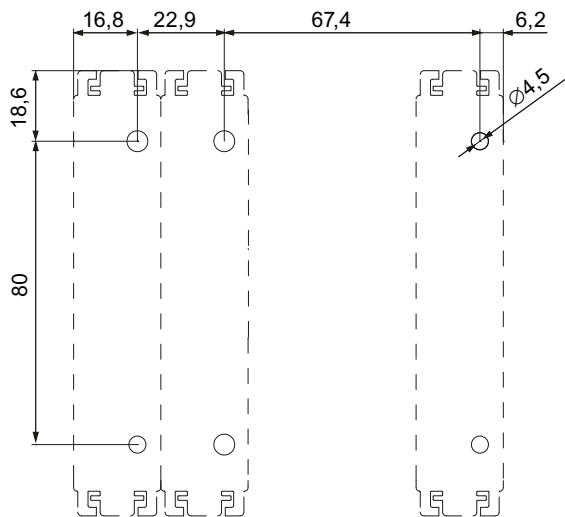

3. Note the clearances required for the 90 mm devices.
Mount the device connector supplied in the set for enclosures of 45 mm upwards (right-hand side).

Tightening torques:

- Top: < 0.1 Nm
- Bottom: 1 Nm

4. Hold the device connector against the level surface prepared for screw fastening.

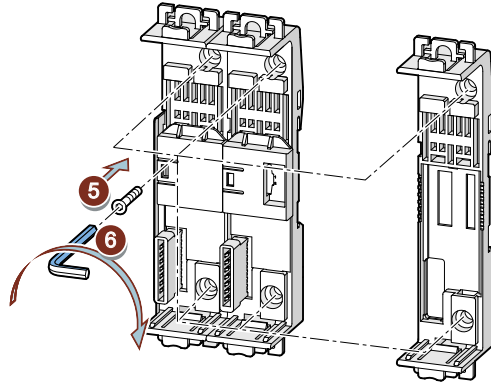

5. Insert the screws through the holes in the device connectors.
6. Screw the device connector securely onto the level surface.

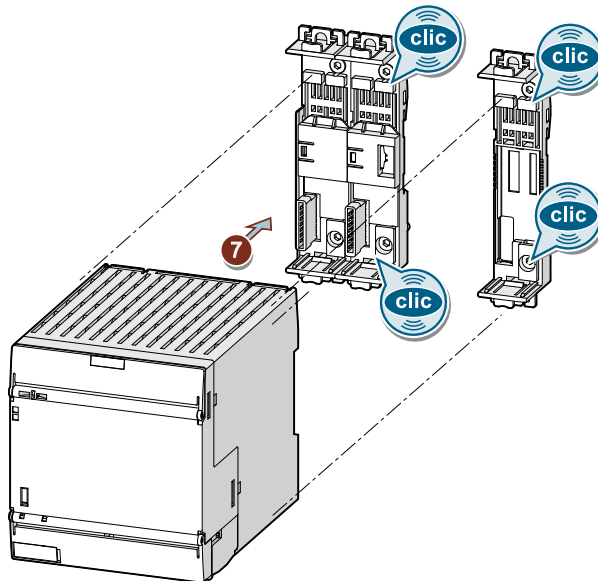

7. Mount the 3SK1213 output expansion on the device connectors.

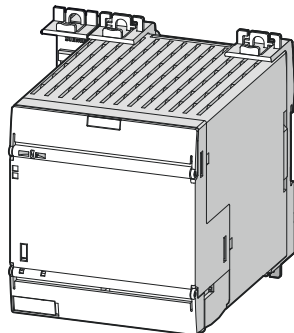

8. Mount all the devices required for the system configuration in accordance with the respective installation guidelines on the device connectors.

7.15 Removing 90 mm devices with device connectors from wall

⚠ WARNING

Hazardous Voltage

Can Cause Death, Serious Injury, or Property Damage.

Before starting work, therefore, disconnect the system and devices from the power supply.

Requirements

- The terminals have been removed or disconnected.

Procedure

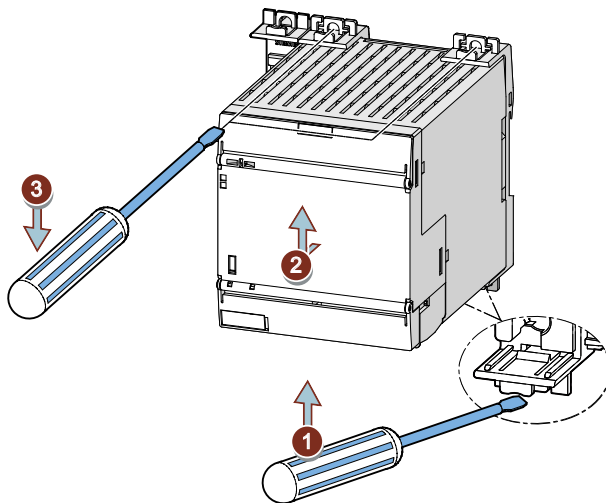

1. Unlock the device (bottom) using a screwdriver.
2. Pull the lower half of the device away from the device connector.

7.15 Removing 90 mm devices with device connectors from wall

3. Unlock the device (top) using a screwdriver.

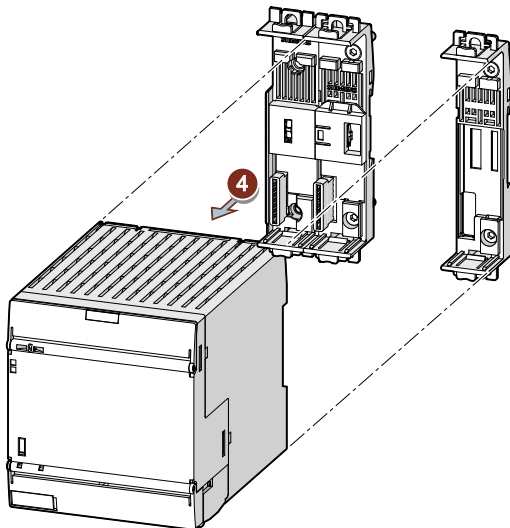

4. Pull the device away from the device connector.

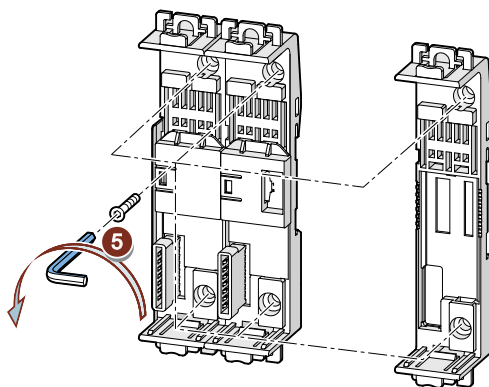

5. Release the screws.

6. Separate the device connectors.

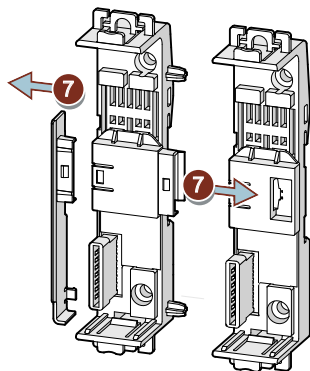

7. Remove the cover.

7.16 Mounting the sealable cover

The sealable cover (3ZY1321-1AA00 for 17.5 mm devices, 3ZY1321-2AA00 for 22.5 mm devices) can be used to secure the DIP switches (and, if present, the potentiometers for setting the delay time) of the safety relays against unauthorized or unintended readjustment.

As an alternative, Siemens also offers a sealable membrane (3TK2820-0AA00) for securing the safety relays. The sealable membrane is fixed to the front of the safety relay and secures the DIP switches and the buttons (and potentiometers) against unintentional readjustment.

Mounting the sealable cover

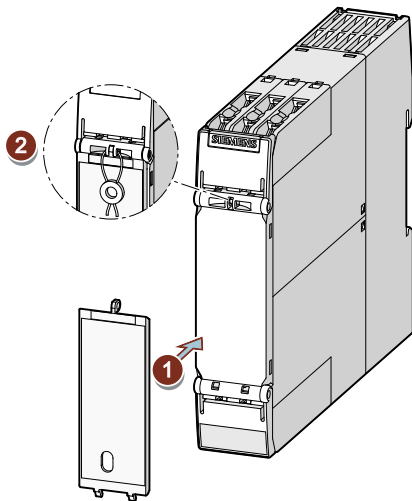

1. Attach the hooks on the cover to the openings on the device and fold the cover up.
2. Seal the cover to secure it against unauthorized removal.
Sealing wire diameter, max.: 2 mm

Connection

8.1 Warning notices

 WARNING
Hazardous Voltage Can Cause Death, Serious Injury, or Property Damage. Hazardous electrical voltages can cause electric shock, burns and damage. <ul style="list-style-type: none">• Turn off and lock out all power supplying the system and device before working on the device.• To ensure protection against the hazard of electric shock when the terminal cover is open, screw in all terminal screws that are not needed to clamp conductors.• Close the terminal covers and always keep them closed during operation.

 DANGER
Hazardous voltage. Can cause death or serious injury To ensure touch protection and degree of protection IP20, screw in all screws which are not used for conductor clamping and close the terminal covers.

8.2 22.5 mm/17.5 mm devices

8.2.1 Terminal assignment

Location of the connections

The inside faces of the terminal covers are labeled with the designations of the relevant terminals. The position of the label corresponds to the position of the respective terminal.

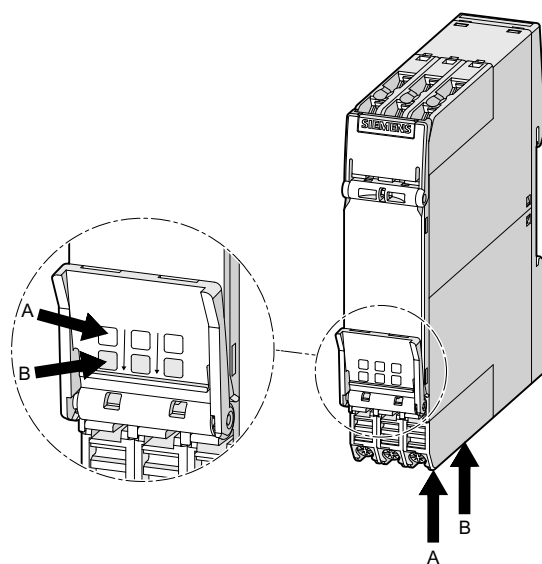
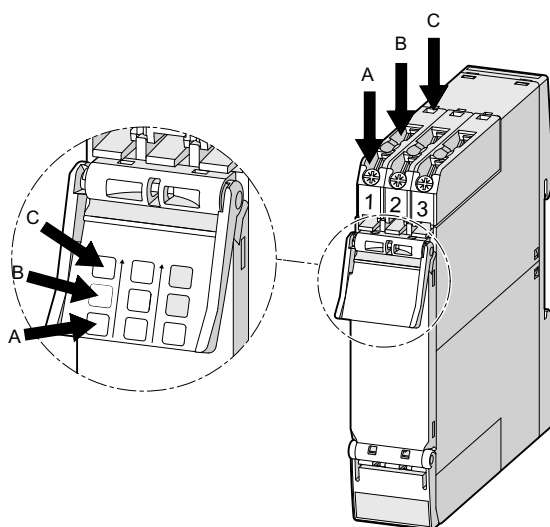

8.2.2 Connection data for 3RQ1 screw terminal

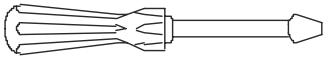
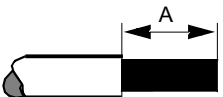
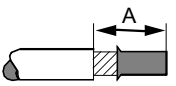
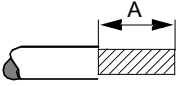
	Specification and value in the case of removable terminals with screw-type terminals
Screwdriver 	Cross-tip screwdriver Size: PZ 1x80 (∅ 4.5 mm) Torque: 0.6 to 0.8 Nm
Rigid cable 	A = 10 mm 1 x 0.5 ... 4.0 mm ² 2 x 0.5 ... 2.5 mm ²
Flexible conductor with end sleeve 	A = 10 mm 1 x 0.5 ... 4.0 mm ² 2 x 0.5 ... 1.5 mm ²
Flexible cable 	Not permissible
AWG	1 x 20 to 12 2 x 20 to 14

8.2.3 Connecting the screw-type terminals

 WARNING Hazardous Voltage Can Cause Death, Serious Injury, or Property Damage. Before starting work, therefore, disconnect the system and devices from the power supply.
--

Tools and materials

- Cross-tip screwdriver size PZ 1 x 80.

Procedure

1. Insert the relevant cable into square on the screw-type terminal until it engages.
2. Hold the cable in the screw-type terminal.

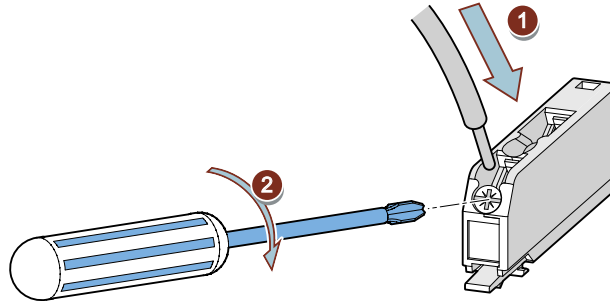

3. Tighten the screw with a torque of 0.6 ... 0.8 Nm.
4. Pull on the cable to ensure it is screwed tight.

8.2.4 Disconnecting the screw-type terminals

 WARNING
<p>Hazardous Voltage Can Cause Death, Serious Injury, or Property Damage.</p> <p>Before starting work, therefore, disconnect the system and devices from the power supply.</p>

Tools

- Cross-tip screwdriver size PZ 1 x 80

Procedure

1. Unscrew the screw of the screw-type terminal.
2. Remove the cable from the unscrewed screw terminal.

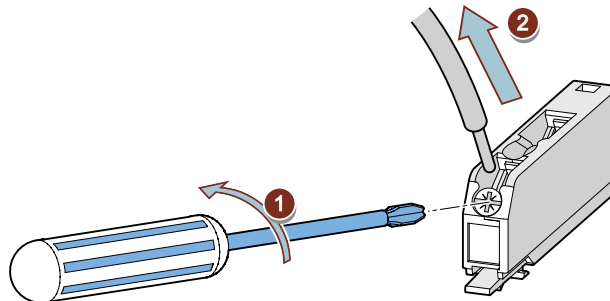

8.2.5 Wiring rules for spring-loaded terminal (push-in system)

Notes on handling spring-loaded terminals (push-in system)

The terminal area of the spring-loaded (push-in) terminals is rectangular, and the maximum overall dimensions of the conductor to be wired must not exceed 1.5 x 2.4 mm (control current terminals).

Attention must be paid to the orientation of the terminal area, which may call for vertical fitting of rectangularly crimped cables.

To make optimum use of available terminal area, you are advised to choose a form of crimping that creates a corresponding rectangular contour. Trapezoidal crimping is generally very highly suitable in this case.

When use is made of a cable that utilizes the full overall height, the terminal's spring is deflected to the maximum. Therefore, removal of this cable may become a problem because it requires further deflection of the spring.

Control current terminals

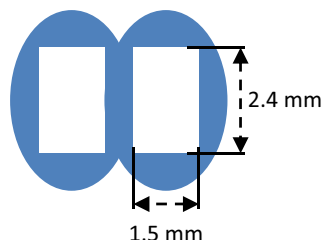

Terminal area of control current terminals

8.2.6 Connection data for 3SK1 spring-loaded terminal (push-in system)

Connection data for ...		Control current terminals
Connectable conductor cross-sections for solid cables		2 x 0.5 ... 2 x 1.5 mm ² (AWG ¹⁾ : 20 ... 16)
Connectable conductor cross-sections for flexible cables	Without end sleeve	2 x 0.5 ... 2 x 1.5 mm ² (AWG ¹⁾ : 20 ... 16)
	With end sleeve (with and without plastic sleeve)	2 x 0.5 ... 2 x 1.0 mm ² ²⁾ (AWG ¹⁾ : 20 ... 18)
	With TWIN end sleeve	--- ---
Cable stripping length		10 ... 11 mm
End sleeves according to DIN 46228-4 with plastic sleeve		10 mm

¹⁾ AWG: American Wire Gauge (AWG does not define use of end sleeves)

²⁾ When 2 x 1.0 mm² end sleeves with a plastic sleeve are used, space problems may arise with the sleeves; as an alternative, you are advised to use end sleeves without plastic sleeves

8.2.7 Connection data for 3RQ1 spring-loaded terminal (push-in system)

Connection data for ...		Control current terminals
Connectable conductor cross-sections for solid cables		1 x (0.5 .. 4.0) mm ² (AWG ¹⁾ : 1 x 20 to 12)
Connectable conductor cross-sections for flexible cables	Without end sleeve	1 x (0.5 ... 4.0) mm ² (AWG ¹⁾ : 1 x 20 to 12)
	With end sleeve (with and without plastic sleeve)	1 x (0.5 ... 2.5) mm ² (AWG ¹⁾ : 1 x 20 to 12)
Cable stripping length		10 mm
End sleeves according to DIN 46228-4 with plastic sleeve		10 mm

¹⁾ AWG: American Wire Gauge (AWG does not define use of end sleeves)

8.2.8 Connecting spring-loaded (push-in) terminals

<p> WARNING</p> <p>Hazardous Voltage Can Cause Death, Serious Injury, or Property Damage.</p> <p>Before starting work, therefore, disconnect the system and devices from the power supply.</p>

The spring-loaded (push-in) system allows wiring without tools for rigid conductors or conductors equipped with end sleeves.

A screwdriver is required for wiring finely-stranded or stranded conductors without end sleeves on spring-loaded (push-in) terminals.

Tools and materials

- 0.5 x 3 mm screwdriver DIN 5264 (for finely-stranded conductors only).

Procedure

Rigid cables or cables equipped with end sleeves

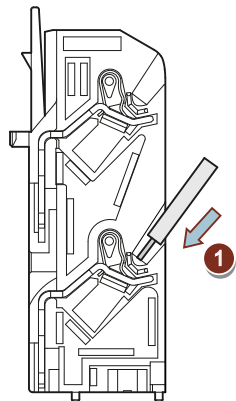

1. Insert the cable into the oval opening as far as it will go.
2. Pull on the cable to ensure it is tight.

Finely-stranded cables

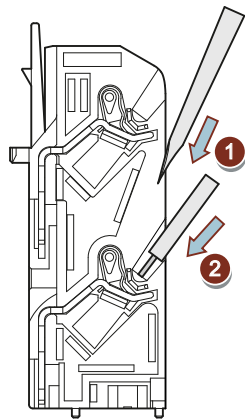

1. Insert the screwdriver in the rectangular opening to open the terminal (oval opening).
2. Insert the cable as far as it will go into the oval opening and remove the screwdriver.
3. Pull on the cable to ensure it is tight.

8.2.9 Disconnect the spring-loaded (push-in) terminal

⚠ WARNING
Hazardous Voltage Can Cause Death, Serious Injury, or Property Damage. Before starting work, therefore, disconnect the system and devices from the power supply.

Tools

- Screwdriver DIN 5264 of the size 0.5 x 3 mm

Procedure

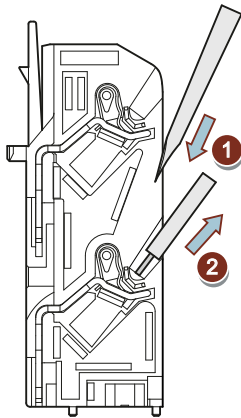

1. Insert the screwdriver into the rectangular opening of the spring-loaded (push-in) terminal until it engages.
2. Remove the cable from the oval opening.
3. Remove the screwdriver.

8.2.10 Attaching the terminals

⚠ WARNING
Hazardous voltage Can Cause Death, Serious Injury, or Property Damage. Before starting work, therefore, disconnect the system and devices from the power supply.

Requirements

You must have removed the terminals, for the purpose of replacing a device, for example.

Procedure when plugging in the terminals

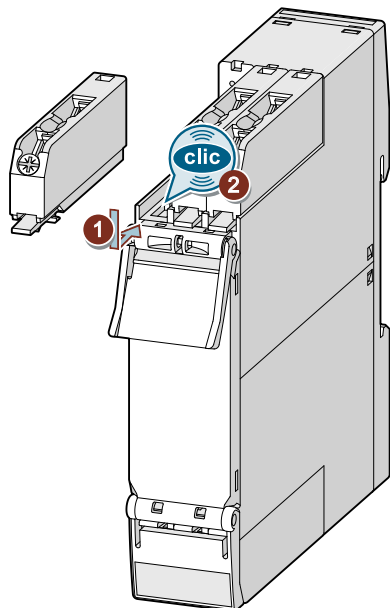

1. Insert the detachable terminals into the guide rail of the device.
2. Slide the detachable terminals back until they audibly engage.

8.2.11 Disconnecting

WARNING

Hazardous voltage

Can Cause Death, Serious Injury, or Property Damage.

Before starting work, therefore, disconnect the system and devices from the power supply.

Removing terminals from the device

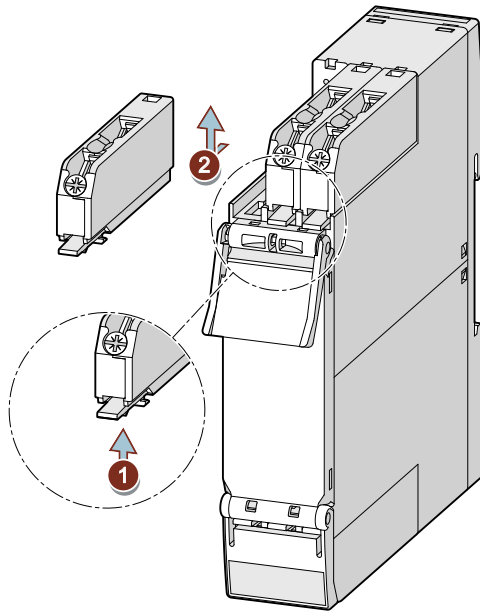

1. Press the clip of the terminals upwards.
2. Pull the terminals out to the front.
3. Lift the terminals out of the guide rail of the device.

Screw terminals: Disconnecting the conductor

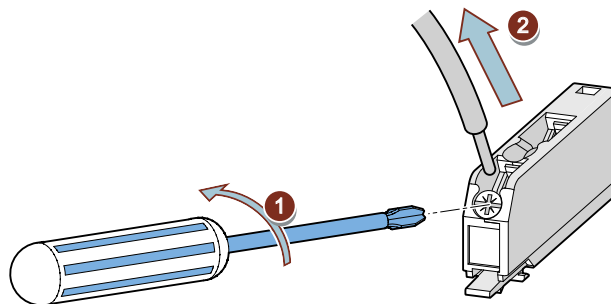

1. Unscrew the screw of the screw-type terminal.
2. Remove the cable from the unscrewed screw-type terminal.

Push-in terminals Disconnecting the conductor

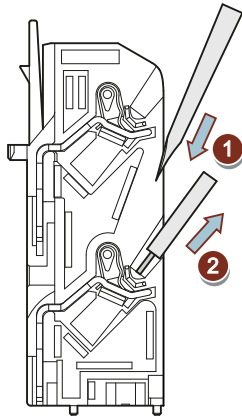

1. Insert the screwdriver into the rectangular opening of the push-in terminal until it engages. Please observe a 10° horizontal angular deviation of the screwdriver to the oval opening.
2. Remove the cable from the oval opening.
3. Remove the screwdriver.

8.3 Devices 90 mm

8.3.1 Opening the terminal cover

 WARNING
Hazardous voltage
Can Cause Death, Serious Injury, or Property Damage.
Before starting work, therefore, disconnect the system and devices from the power supply.

Positions of the terminals and opening the terminal cover

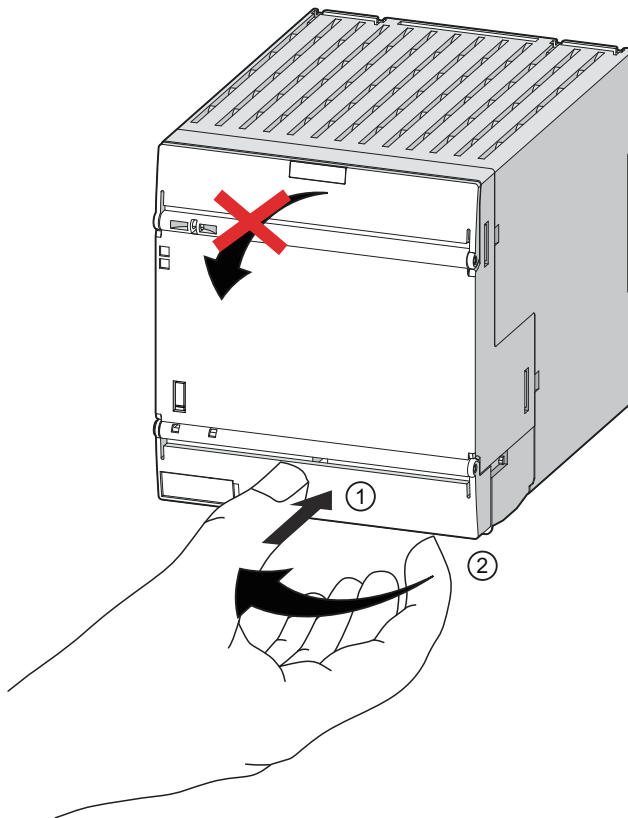

The removable terminals are located under the **lower** terminal cover.
To open the terminal cover, press on it in the middle ① and lift it up ②.

8.3.2 Connection data for terminals

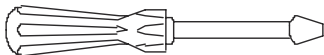
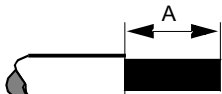
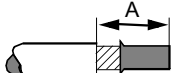
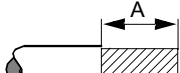
	Screwdriver for removable terminals with screw terminal	Screwdriver for removable terminals with spring- loaded connection
Screwdriver 	Cross-tip screwdriver Size: PZ 1 (ø 4 mm) Torque: 0.8 to 1.2 Nm	Screwdriver Size: 0 or 1 (width to 3 mm) for raising the terminal springs DIN 5264-A; 0.5 x 3
Rigid cable 	A = 10 mm 1 x 0.5 ... 4.0 mm ² 2 x 0.5 ... 2.5 mm ²	A = 10 mm 1 x 0.5 ... 1.5 mm ² 2 x 0.5 ... 1.5 mm ²
Flexible cable with end sleeve/cable lug 	A = 10 mm 1 x 0.5 ... 2.5 mm ² 2 x 0.5 ... 1.5 mm ²	A = 10 mm 1 x 0.5 ... 1.5 mm ² 2 x 0.5 ... 1.5 mm ²
Flexible cable 	Not permissible	A = 10 mm 1 x 0.5 ... 1.5 mm ² 2 x 0.5 ... 1.5 mm ²
AWG	1 x 20 to 12 2 x 18 to 14	1 x 20 to 16 2 x 20 to 16

8.3.3 Connecting terminals

 WARNING Hazardous voltage Can cause death, serious injury, or property damage. Before starting work, therefore, disconnect the system and devices from the power supply.
--

Procedure for screw terminal blocks

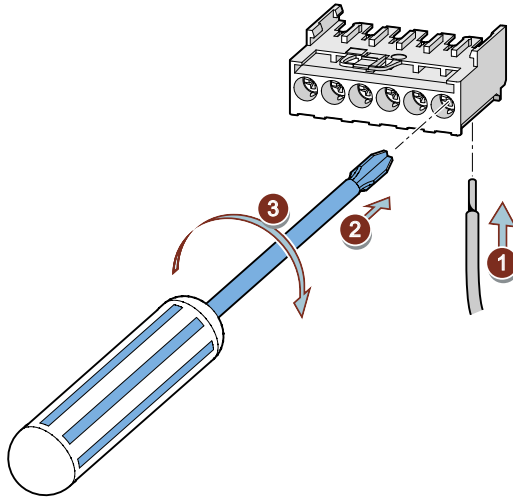

1. Insert the relevant cable into square on the screw-type terminal until it engages.
2. Hold the cable in the screw-type terminal.
3. Tighten the screw of the terminal in which the cable is inserted.
4. Pull on the cable to ensure it is screwed tight.

Procedure for spring-loaded terminals

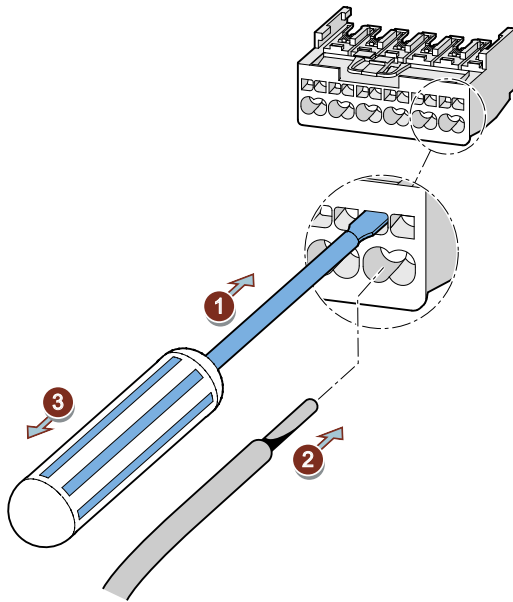

1. To release the terminal springs, insert the screwdriver as far as it will go into the rectangular opening of the spring-loaded terminal. Please observe a 10° horizontal angular deviation of the screwdriver to the oval opening.
2. Insert the cable into the oval opening as far as it will go.

3. Hold the cable in the spring-loaded terminal.
4. Remove the screwdriver.
5. Pull on the cable to ensure it is tight.

8.3.4 Mounting terminals

⚠ WARNING

Hazardous voltage

Can Cause Death, Serious Injury, or Property Damage.

Before starting work, therefore, disconnect the system and devices from the power supply.

Requirements

You must have removed the terminals, for the purpose of replacing a device, for example.

Procedure for mounting terminals

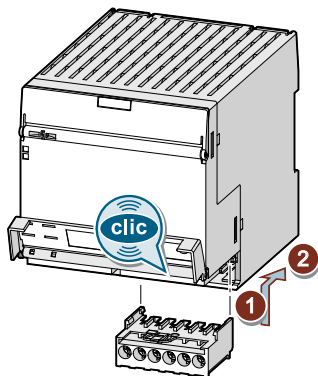

1. Insert the detachable terminals into the guide rail of the device.
2. Slide the detachable terminals back until they audibly engage.
3. Check that the clip of the removable terminals closes flush with the front panel.

8.3.5 Disconnecting

⚠ WARNING
Hazardous Voltage Can Cause Death, Serious Injury, or Property Damage.
Before starting work, therefore, disconnect the system and devices from the power supply.

Removing terminals from the device

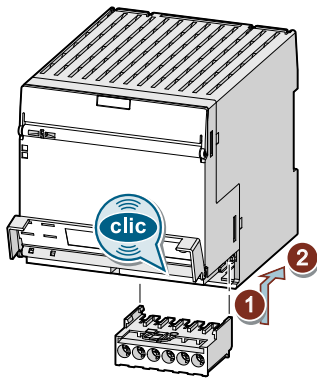

1. Insert a flat-head screwdriver between the clip of the terminals and the front panel.
2. Pull the terminals out to the front.
3. Lift the terminals out of the guide rail of the device.

Disconnecting the screw terminal

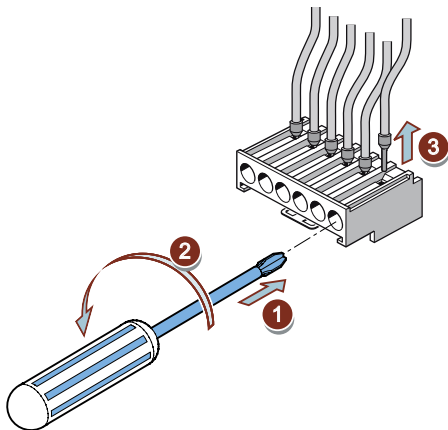

1. Insert the screwdriver into the screw-type terminal.
2. Unscrew the screw of the screw-type terminal.
3. Remove the cable from the unscrewed screw-type terminal.

Disconnecting the spring-loaded terminal

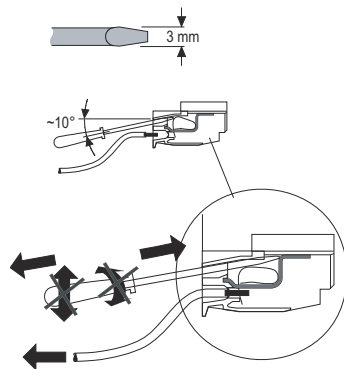

1. Insert the flat-head screwdriver into the rectangular opening of the spring-loaded terminal until it engages. Please observe a 10° horizontal angular deviation of the screwdriver to the oval opening.
2. Remove the cable from the oval opening.
3. Remove the screwdriver.

8.4 Device replacement

 WARNING
Hazardous Voltage Can Cause Death, Serious Injury, or Property Damage.
Before starting work, therefore, disconnect the system and devices from the power supply.

When replacing a device, you do not need to re-wire it. The terminals can be disconnected from the defective device and then connected to the new device.

You can provide the terminals with coding pins. These are to help you avoid errors when replacing the terminals (see the chapter "Terminal coding (Page 62)" for more details).

Replacing the module

 WARNING
Hazardous Voltage Can Cause Death, Serious Injury, or Property Damage. Carry out function test of the plant
To ensure the safety of the system, a full functional test must be conducted and a successful result obtained after a device has been replaced.

Note

Only replace a defective device with a device of an identical article number.

1. Disconnect the defective device at the terminals.
 - Chapter for 22.5 mm / 17.5 mm devices "Disconnecting (Page 101)"
 - Chapter for 90 mm devices "Disconnecting (Page 108)"
2. Deinstall the defective device.
 - Chapter "Removing devices from a standard mounting rail (Page 69)"
 - Chapter "Removing 22.5 mm/17.5 mm devices with device connectors from a standard mounting rail (Page 73)"
 - Chapter "Removing 90 mm devices with device connectors from a standard mounting rail (Page 79)"

3. Mount the new device
 - Chapter "Mounting the devices on a level surface (Page 63)"
 - Chapter "Mounting 22.5 mm/17.5 mm devices on a standard mounting rail (Page 67)"
 - Chapter "Mounting the 90 mm devices on a standard mounting rail (Page 68)"
 - Chapter "Mounting 22.5 mm/17.5 mm devices with device connectors on the wall (Page 82)"
 - Chapter "Mounting 90 mm devices with device connectors on the wall (Page 87)"
4. Connect the defective device at the terminals
 - Chapter for 22.5 mm / 17.5 mm devices "Connecting the screw-type terminals (Page 95)", "Connecting spring-loaded (push-in) terminals (Page 98)" and "Attaching the terminals (Page 100)"
 - Chapter for 90 mm devices "Connecting terminals (Page 105)" and "Mounting terminals (Page 107)"
5. Set the DIP switches/slide switches and, if applicable, the times according to the defective device.

After applying the supply voltage, the new 3SK1 basic unit checks whether the hardware configuration matches the device configuration.

If there are no deviations, the system re-enters safety mode.

Configuration / operation

Note

This chapter only refers to the 3SK1 basic units. If the 3RQ1 force-guided coupling relay is used without 3SK1 basic units, this chapter does not contain any relevant information.

9.1 Procedure for configuration

General information:

- It is only possible to change the configuration (DIP switch, NC/NO evaluation, potentiometer, input and output expansion) in configuration mode. Modifications during operation are not accepted.
- A configuration change (DIP switch, NC/NO evaluation, potentiometer) is indicated in safety mode by the "DEVICE" LED flashing green/yellow, but does not change the device function.
- In safety mode, if a change in the system configuration (input and output expansion) is detected, the device switches to error mode ("DEVICE" LED and "SF" LED red). A restart is only possible using Power OFF/ON.

Procedure for configuring a basic unit

1. Set the configuration (DIP, PAR, potentiometer, input expansion, output expansion) in accordance with the desired function.
2. Connect the power supply.
3. If the device detects a modified configuration, it remains in configuration mode (LEDs flash) during power up.
4. Confirm the new configuration by operating the SET/RESET pushbutton for more than 1s.
5. The configuration has been accepted and the device changes to safety mode.

Note

Configuration and setting the delay time

A change to the configuration must only ever be carried out when the system is disconnected from the power.

In safety mode, an adjustment to the potentiometer does not result in a change to the parameterized delay time.

A change to the potentiometer setting made during operation is not accepted and is indicated in safety mode by a yellow/green flashing "DEVICE" LED. The device can be restarted by performing a RESET (pressing the SET/RESET button) or by disconnecting and reconnecting the supply voltage. Following a restart, the device remains in safety configuration mode during power up (all safety-related outputs are shut down) until the new delay time is accepted by pressing the SET/RESET button.

9.2 Explanation of the device's functions

Explanation of the device functions (DIP switches)

DIP switch	Parameter	Function
1	Start type	<ul style="list-style-type: none"> • Autostart: The safety-related outputs are switched to the active position as soon as the switch-on condition is satisfied at the sensor inputs IN1, IN2, INF and INK. The START button connecting terminal INS is not queried. • Monitored start: The safety-related outputs are switched to the active position as soon as the switch-on condition is met at the IN1, IN2, INF and INK sensor inputs and the START button at the INS terminal is actuated (start with the falling edge).
2	Cross-circuit detection	<p>Cross-circuit detection is only possible with floating sensors. The sensors must be connected between T1 - IN1 and T2 – IN2. At the terminals IN1 and PAR (if used), the test signal of terminal T1 is expected; at the terminals IN2 and INF, the test signal of T2 is expected. The device detects a sensor fault if the signal at the terminals IN1, PAR or IN2, INF does not match the test signals T1, T2.</p> <p>Cross-circuit detection must be deactivated if electronic sensors such as light arrays or laser scanners are connected. The 3SK1 now no longer monitors the sensor inputs for cross-circuit detection. Usually, the outputs of safety sensors (OSSD) are already monitored for cross-circuits in the sensor.</p> <p>Devices with PAR terminals expect the test signal T2 at the parameterization input. A 24 V signal at the PAR or INF terminals results in a fault (cross-circuit at the input).</p>
3	Type of connection	<ul style="list-style-type: none"> • 1 sensor with 2 contacts 1 x two-channel; NC/NC. It is expected here that both contacts be open simultaneously. With the additional connection of T1 to PAR, this DIP parameterization applies to ONE two-channel sensor with NC/NO contacts. • 2 sensors with one contact each 2 x single-channel; NC / NC. In this case, both sensors are AND-connected. Simultaneity is not monitored.
4	Startup testing	After a power failure, startup testing requires that the sensors at IN1 and IN2 are actuated once by the system operator.

INK input for cascading

The INK cascading input is set up redundantly from the terminal in the device.

With protected installation, safety applications up to Performance Level e (PL e) or Safety Integrity Level 3 (SIL 3) can be implemented.

This applies if the connected sensor or output is suitable.

The INK cascading input can be used for the following applications:

- Safe connection of safety relays
In this application, a higher-level safety relay switches off the 3SK1 safety relay via the cascading input via a safe output.
- Additional safety sensor circuit
The cascading input INK is AND-linked with the sensor inputs IN1 and IN2.
The cascading input can be connected to 1-channel safety sensors (forced opening). The start function for the INK cascading input corresponds to the start response of sensor inputs IN1 and IN2 (autostart or monitored start).
- Functional switching
The INK cascading input can also be used for normal switching duty (not safe).

When using a 3SK1 safety relay with instantaneous and time-delayed contacts, the two following safety notes must always be observed:

NOTICE

In the event of external faults such as:

- Cross-circuit fault
- Short circuit to ground
- Current-source short circuit

and to access the configuration mode for copying a delay time after a reset, the following device behavior must always be taken into account:

The outputs of stop category 0 switch instantaneously, while the outputs of stop category 1 have a time delay.

The sequence cannot be interrupted.

Exception: Switching off the power supply.

NOTICE**Saving the starting command:**

1. If the safe state is restored during the time delay, (e.g. the protective door is closed) and the START button is actuated, the safety-related outputs switch to the active position immediately after the delay time has elapsed.
The actuation of the START button is saved.
The OFF-delayed enabling contacts or outputs of the 3SK112-CB4 safety relays (relay and semiconductor outputs) cannot be retriggered. This means that if an OFF command in the sensor circuit is canceled before the delay time has elapsed, the delay time still elapses in full length. If a start command has been issued during this time or if autostart has been set, after this time has elapsed the OFF-delayed enabling contacts switch off briefly and switch on again immediately with the instantaneous enabling contacts (start command is saved).
2. If a sensor is actuated at an input expansion within the system configuration, the entire system is disconnected. If the sensor at the input expansion is activated (e.g. protective door is open) and the START button on the basic unit is actuated, this command will be saved by the basic unit. This results in an automatic start of the system once the sensor at the input expansion is reset (for example, a protective door is closed again). This system response is identical in the system configuration for all 3SK1 basic units.

For additional notes/explanations on this topic, see the following FAQ (<https://support.industry.siemens.com/cs/ww/en/view/103655974>)

NOTICE**Observe the following in the case of protective doors with tumblers:**

If the voltage U_s is disconnected on devices with time-delayed outputs between switching the instantaneous outputs and the time-delayed outputs, the delay time expires when the voltage U_s is restored, and the time-delayed contacts change their switch positions.

9.3 Modes

The 3SK1 safety relays have 4 main operating modes:

- Power-up
- Configuration mode
- Safety mode
- Error mode

Power-up

During start-up (up to 7 seconds), the 3SK1 safety relay runs through a complete function test.

Configuration mode

A saved configuration can only be modified in configuration mode.

The configuration must only ever be modified after disconnecting the power supply.

If the device detects a configuration change during the restart (DIP, PAR, potentiometer, input expansion, output expansion), it does not change automatically to safety mode after power up, but instead remains in configuration mode.

In configuration mode, those LEDs flash yellow whose ON DIP switch position is on the right; all other parameter settings are not explicitly indicated.

The configuration is accepted by pressing the SET/RESET button for approximately 1 s.

In configuration mode, the device is in the safe state. No monitoring functions are active.

Note

A configuration change made during operation is not accepted, and in safety mode, this is indicated by a yellow/green flashing "DEVICE" LED. The device can be restarted by performing a RESET (pressing the SET/RESET button) or by disconnecting and reconnecting the supply voltage.

Safety mode (DEVICE LED: green)

In safety mode, all monitoring functions are active in accordance with the set configuration.

Note

Parameterized startup testing is indicated by a green flashing "DEVICE" LED. Only when this has been successfully executed does the "DEVICE" LED show a green light.

Error mode

Error mode is indicated by a red "DEVICE" LED or by a red "SF" LED. In error mode, the device **ALWAYS** changes to the safe state.

9.4 Response times

Verification of response times in the case of safety circuits

When safety equipment is commissioned, steps must be taken to verify that a safety-related output will switch off within a maximum permissible response time if the input signal changes at the relevant input.

To provide this verification, you must determine the total response time of the application you have configured.

Note

Note that the calculation of the response time affects the level of safety and governs the overall design of the system.

You can find the response data of the safety relays in the technical specifications of the respective devices in the chapter "Technical data (Page 129)".

You can find the response data of the 3RM1 Failsafe motor starters in the technical specifications in the "SIRIUS 3RM1 motor starters (<http://support.automation.siemens.com/WW/view/EN/66295730>)" manual.

Calculation of the response times

To calculate the response times of the overall system configuration, you must add up the individual response times of all input expansions affected by deactivation and also the response time of the basic unit.

If output expansions are used, the response times of the relevant output module are also added to the total time from the sensor to the actuator.

Commissioning

Note

Since commissioning of the 3SK1 safety relays is an important, safety-related step, it must be carried out by qualified personnel.

 WARNING**Hazardous voltage**

**Can cause death, serious injury, or property damage.
Carry out function test of the plant.**

To guarantee the safety of the system, a full functional test must be carried out and successfully concluded following commissioning.

Commissioning 3SK1 safety relays

3SK1 safety relays are commissioned by applying the operating voltage.

After the supply voltage has been applied, all LEDs show a green light for about 1 s (lamp test). The LEDs then go out for approx. 0.5 s. The device configuration is then displayed on the configuration LEDs for approx. 3 s.

If no configuration change (DIP, PAR, potentiometer, input expansion, output expansion) has been detected, the device changes automatically to safety mode and is ready for operation. However, if the device detects a deviation of the set parameters from the saved configuration, it remains in safe configuration mode until the new configuration is accepted by pressing the SET/RESET button.

Note**Observe the following during commissioning:**

The cascading input must be bypassed (24 V DC) if it is not to be used.

Monitoring of the feedback circuits is not optional.

Display and diagnostics

11.1 LED display

The LED displays of the 3SK1 Advanced safety relays are shown in the tables below.

LED	Display	Explanation
(1) DEVICE	OFF*	No voltage, group error Configuration mode DIP (1) position: left
	Green	Device is ready for operation Power-up: hardware test
	Green flashing	No startup testing Short-circuit on the SET/RESET button
	Yellow	Power-up DIP (1) position: right
	Yellow flashing	Configuration mode DIP (1) position: right
	Green/yellow flashing	Configuration changed
	Red	Device error
(2) OUT	OFF*	Output inactive Configuration mode DIP (2) position: left
	Green	Output active Power-up: hardware test
	Green flashing	Feedback circuit error Short-circuit on the SET/RESET button
	Yellow	Power-up DIP (2) position: right
	Yellow flashing	Configuration mode DIP (2) position: right START button pressed too long
	Green/yellow flashing	Instantaneous outputs inactive, delayed outputs active
(3) IN	OFF*	Start conditions not fulfilled Configuration mode DIP (3) position: left
	Green	Start conditions fulfilled Power-up: hardware test
	Green flashing	<ul style="list-style-type: none"> • If 1 x two-channel: Simultaneity of sensors not fulfilled • Two-hand operation: time monitoring violated • With monitored start: START button not yet pressed Short-circuit on the SET/RESET button
	Yellow	Power-up DIP (3) position: right
	Yellow flashing	Short-circuit of T1/T2 to ground or 24 V With input expansion: missing enabling signal of input expansion Group error: Cross-circuit at input Configuration mode DIP (3) position: right
	Flickering yellow	Configuration mode: Special two-hand operation configuration
	Flickering red	Configuration mode: impermissible configuration

11.1 LED display

LED	Display	Explanation
(4) SF	OFF*	No group error, Configuration mode DIP (4) position: left
	Green	Power-up: hardware test
	Green flashing	Short-circuit on the SET/RESET button
	Yellow	Power-up DIP (4) position: right
	Yellow flashing	Configuration mode DIP (4) position: right
	Red	Group error, e.g. cross-circuit at input, short-circuit to P, device configuration changed.
	Red flashing	Error message (e.g. short-circuit T1/T2, violation of simultaneity, violation of two-hand operation timeout, feedback circuit error, START-button pressed too long, connection of control supply voltage (A1/A2) to an expansion unit that is connected via a device connector)

* LED flashes briefly in configuration mode due to lamp test

11.2 Power-up

Display mode during power-up / parameterization in configuration mode

LED	Display	Explanation
(1) DEVICE	Yellow or yellow flashing	Monitored start
	Off	Autostart
(2) OUT	Yellow or yellow flashing	Cross-circuit detection ON
	Off	Cross-circuit detection off
(3) IN	Yellow or yellow flashing	1 x two-channel
	Flickering yellow	Configuration mode: Special two-hand operation configuration
	Flickering red	Configuration mode: impermissible configuration
	Off	2 x single-channel
(4) SF	Yellow or yellow flashing	Startup testing off
	Off	Startup testing ON

11.3 Error statuses

LED	Display	Explanation
(1) DEVICE	Red	Device error
(4) SF	Red	Group error
	Red flashing	Fault message

11.4 Diagnostics

Power-up

Explanation	DEVICE	OUT	IN	SF
Hardware test Note: Input expansions remain in this state until acknowledged by the device on the right-hand side.	Green	Green	Green	Green
The SET/RESET button is stuck, or has been pressed too long. The device remains in this state until the button is released again.	Green flashing	Green flashing	Green flashing	Green flashing
Display of DIP switch configuration.	If the DIP switch position is at ON (right), the relevant LED shows a yellow light.			

Configuration

Explanation	DEVICE	OUT	IN	SF
Indication of a modified configuration.	If the DIP switch position is at ON (right), the relevant LED flashes yellow			
Special configuration, two-hand operation NC/NO, autostart, 2 x single-channel.	Off	If the DIP switch position is at ON (right), the relevant LED flashes yellow	Flickering yellow	If the DIP switch position is at ON (right), the relevant LED flashes yellow
Impermissible configuration NC/NO, monitored start, 2 x single-channel	Yellow flashing	If the DIP switch position is at ON (right), the relevant LED flashes yellow	Flickering red	If the DIP switch position is at ON (right), the relevant LED flashes yellow
All DIP switches are in OFF position (left)	All LEDs light up briefly (yellow) at intervals			

Safety mode

Explanation	DEVICE	OUT	IN	SF
No startup testing.	Green flashing	Off	Off	Off
Device ready for operation, all outputs OFF.	Green	Off	Off	Off
Device ready for operation, all outputs ON.	Green	Green	Green	Off
Device ready for operation, instantaneous outputs OFF, time-delayed outputs ON.	Green	Green/yellow flashing	Off	Off
If "monitored start": START button not yet pressed.	Green	Off	Green flashing	Off
With input expansion: Missing enabling signal of input expansion.	Green	Off	Yellow flashing	Off
Configuration has been changed (PAR, DIP switch, potentiometer)	Green/yellow flashing	— ¹⁾	— ¹⁾	— ¹⁾

11.4 Diagnostics

Explanation	DEVICE	OUT	IN	SF
If 1 x two-channel: Simultaneity violated If two-hand operation: Time monitoring violated.	Green	Off	Green flashing	Red flashing
Short-circuit test clock output T1 or T2	Green ²⁾	Off	Yellow flashing	Red flashing
If "monitored start": START button was pressed too long or has a short-circuit.	Green	Yellow flashing	Off	Red flashing
Feedback circuit error	Green	Green flashing	Green	Red flashing

¹⁾ Dependent on device status

²⁾ Green flashing DEVICE LED: No startup testing

Error mode

Explanation	DEVICE	OUT	IN	SF
Device error Restart possible by pressing the SET/RESET button.	Red	Off ³⁾	Off ³⁾	Off ³⁾
Group error Restart possible by pressing the SET/RESET button	Off ³⁾	Off ³⁾	Off ³⁾	Red
Group error, cross-circuit at input Restart possible by pressing the SET/RESET button.	Off ³⁾	Off ³⁾	Yellow flashing ³⁾	Red
System stop Restart only possible by disconnecting and re-connecting the operating voltage.	Red	Off ³⁾	Off ³⁾	Red

³⁾ On time-delayed devices, the LED flashes green/yellow provided the time-delayed outputs are still switched on

Technical data

12.1 Technical specifications in the Siemens SiePortal

Technical data sheet

You can find the technical specifications for the product in Siemens SiePortal (<https://support.industry.siemens.com/cs/ww/en/ps/>).

1. Enter the article number of the desired device in the "Products" field.
2. Click the "Technical specifications" link in the result.

12.2 Electrical endurance

You can find FAQs and more tables on the topic of electrical endurance on the Internet (<https://support.industry.siemens.com/cs/us/en/view/109995353>).

Electrical endurance of 3RQ1 coupling relays

Note

When using the devices to equip furnaces to DIN EN 50156-1, the load (utilization category) listed below must not be exceeded.

The electrical endurance is $\geq 250,000$ operating cycles under the following conditions:

Utilization category	3RQ1000-.HB00; 3RQ1000-.LB00; 3RQ1000-.HW00; 3RQ1000-.LW00
AC-1, 240 V	1.5 A
AC-15, 240 V	0.2 A
DC-13, 24 V	2.0 A

Electrical endurance of 3RQ1 coupling relays for the following device versions

3SK1121-.AB40	3RQ1000-.HB00
3SK1111-.AB30	3RQ1000-.LB00
3SK1111-.AW20	3RQ1000-.HW00
3SK1211-.BB40	3RQ1000-.LW00
3SK1211-.BB00	
3SK1211-.BW20	

Utilization category	Ue (V)	Ie (A)	B10 _d value (operating cycles)	Electrical endurance of safety-related outputs (typical)
AC-1	240	5	500,000	85,000
		4	860,000	140,000
		2	1,300,000	210,000
AC-15	240	4	300,000	50,000
		3	850,000	85,000
		1	1,100,000	120,000
DC-13	24	5	300,000	50,000
		2	2,000,000	230,000
		1	7,000,000	1,100,000
DC-1	24	5		500,000

Electrical endurance of 3RQ1 coupling relays for the following device versions

3RQ1.00-.E.00

3RQ1000-.G.00

Utilization category	Ue (V)	Ie (A)	B10 _d value (operating cycles)	Electrical endurance of safety-related outputs (typical)
AC-1	230	5	340,000	170,000
AC-15	230	2	85,000	85,000
	230	1	220,000	220,000
DC-13	24	2	120,000	13,000
DC-1	24	5	1,560,000	780,000

12.3 Overview tables

Overview tables technical data

You will find overview tables with technical data in the "Product information" tab in our online ordering system (<https://sieportal.siemens.com/en-ww/search?scope=catalog&Type=products&SearchTerm=3RQ1&CatalogSearchSettings.Limit=20&CatalogSearchSettings.Index=0&SortingOption=Relevance>).

Dimension drawings

13.1 CAx data in the Siemens SiePortal

You can find CAx data for the product in the SiePortal (<https://support.industry.siemens.com/cs/ww/en/ps/>).

1. Enter the article number of the desired device in the "Products" field.
2. Click the "CAx data" link in the result.

Circuit diagrams

14.1 CAx data in the Siemens SiePortal

You can find CAx data for the product in the SiePortal (<https://support.industry.siemens.com/cs/ww/en/ps/>).

1. Enter the article number of the desired device in the "Products" field.
2. Click the "CAx data" link in the result.

14.2 Internal circuit diagrams

14.2.1 Internal circuit diagrams for expansion units

Output expansion 3RQ1000-.EB00 (24 V DC)

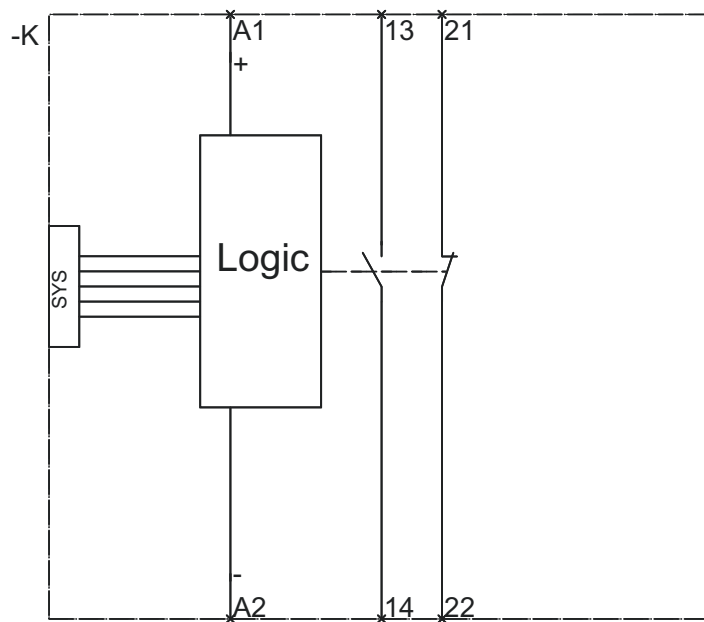

Output expansion 3RQ1000-.EW00 (24 - 240 V AC/DC)

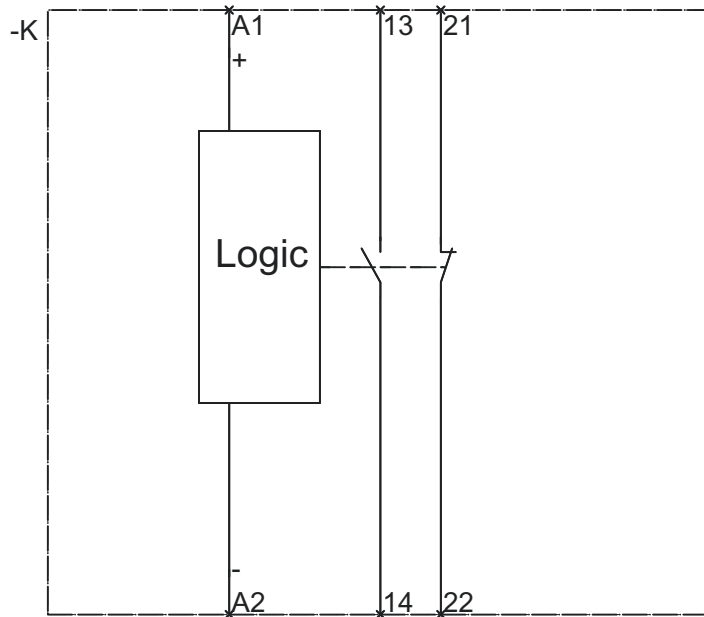

Output expansion 3RQ1000-.GB00 (24 V DC)

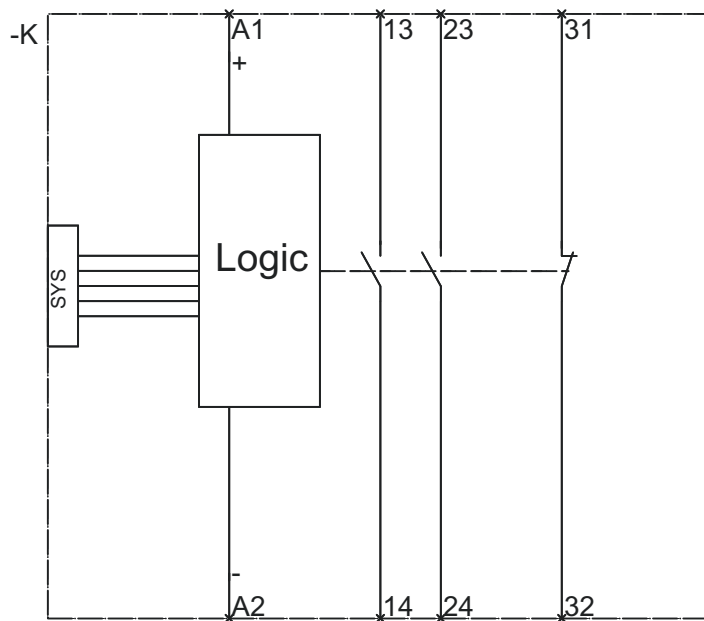

Output expansion 3RQ1000-.GW00 (24 - 240 V AC/DC)

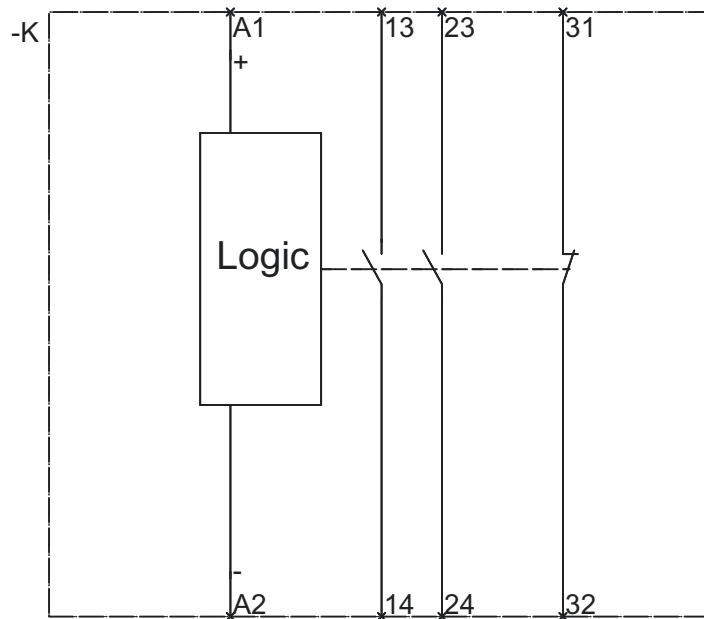

Output expansion 3RQ1000-.HB00 (24 V DC)

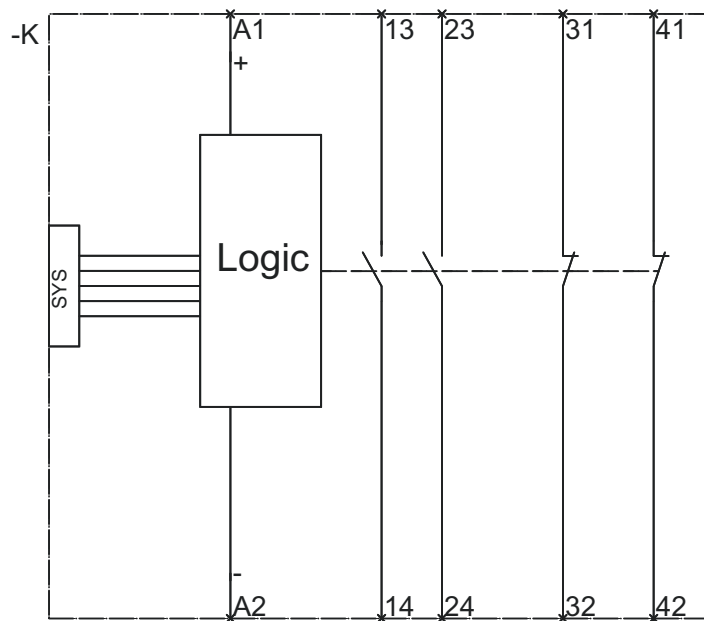

Output expansion 3RQ1000-.HW00 (24 - 240 V AC/DC)

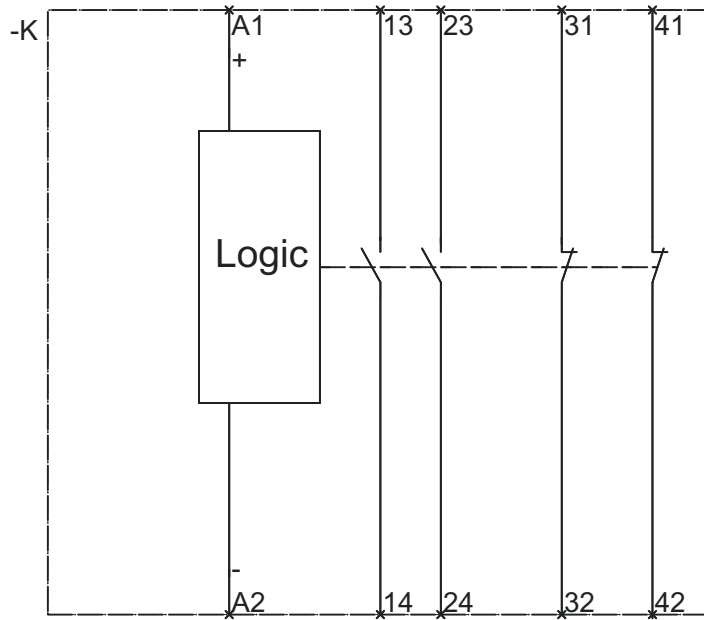

Output expansion 3RQ1000-.LB00 (24 V DC)

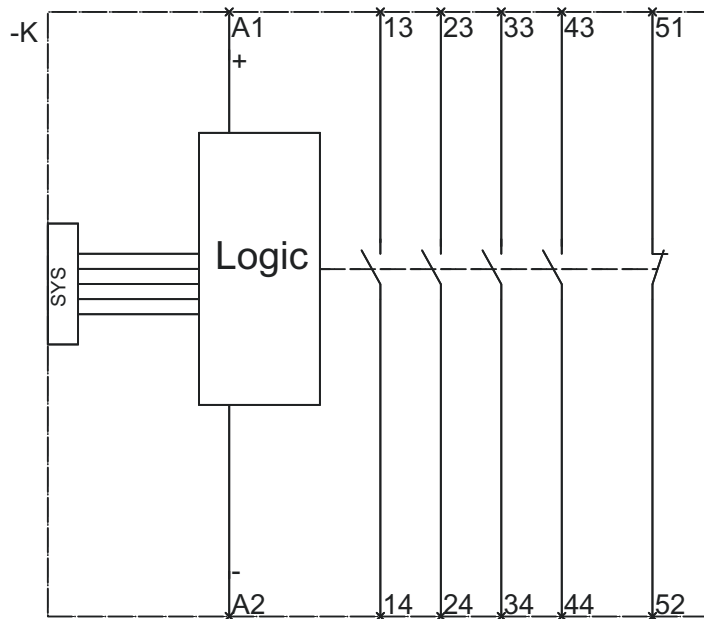

Output expansion 3RQ1000-.LW00 (24 - 240 V AC/DC)

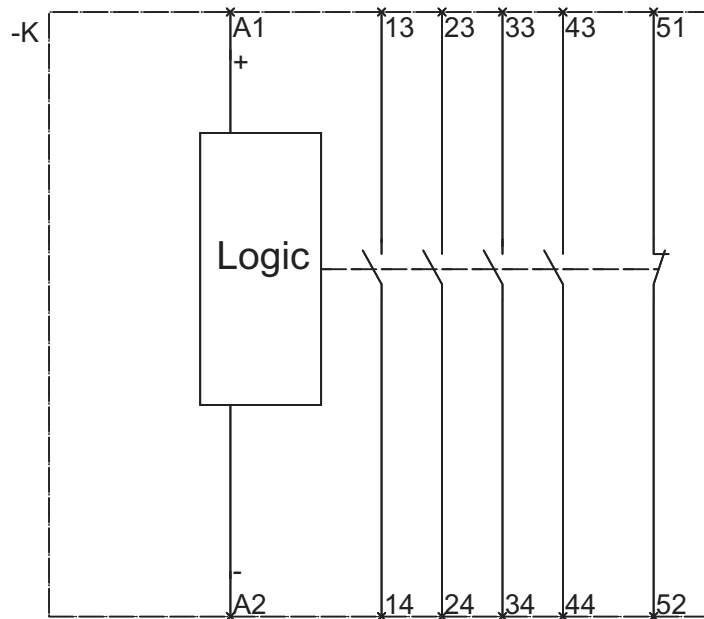

Output expansion 3RQ1200-.EB00 (24 V DC)

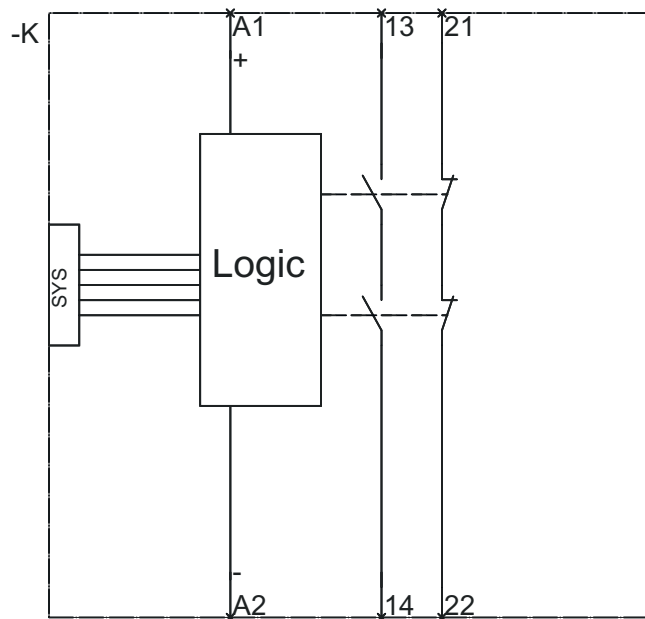

Output expansion 3RQ1200-.EW00 (24–240 V AC/DC)

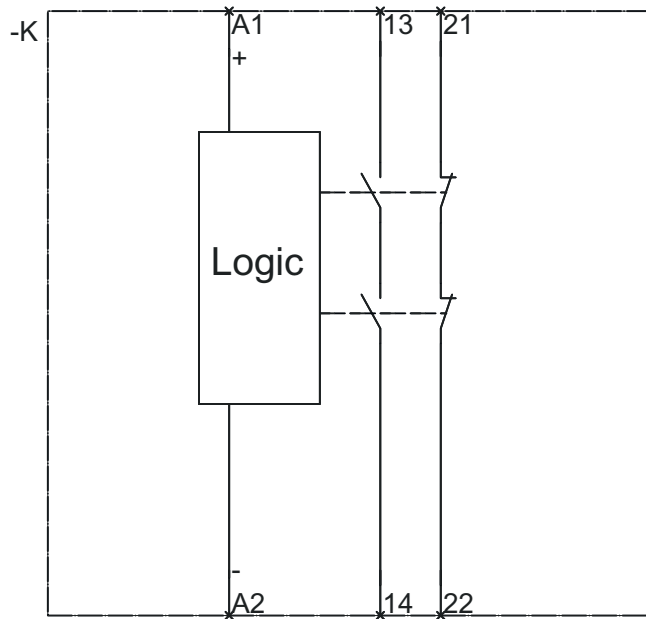

Output expansion 3SK1211 (110–240 V)

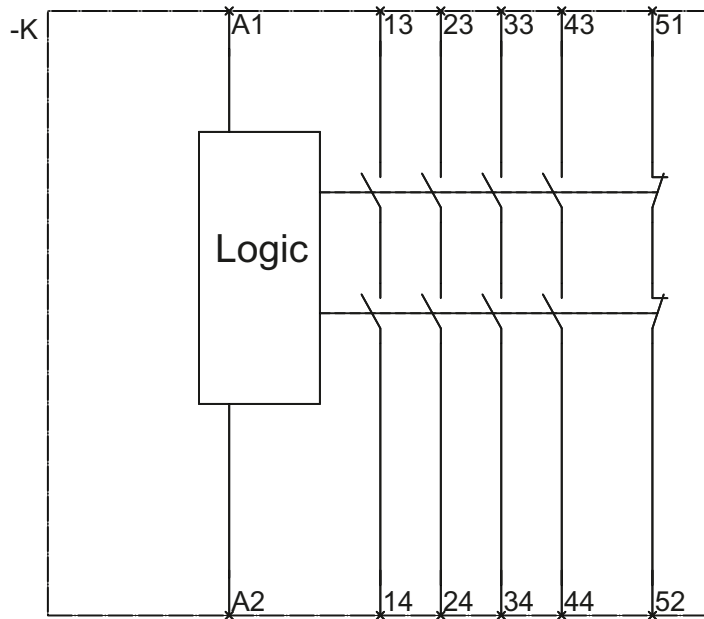

Output expansion 3SK1211 (24 V DC)

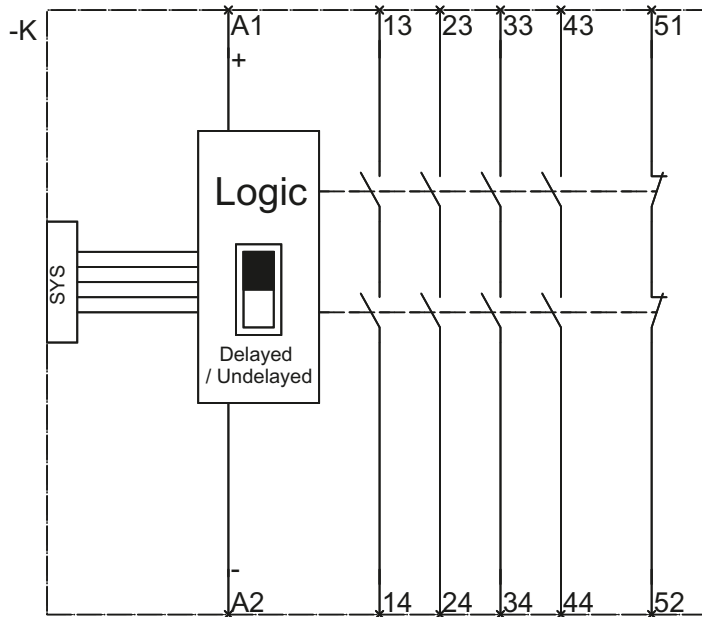

Output expansion 3SK1213-.A.20 (110–240 V)

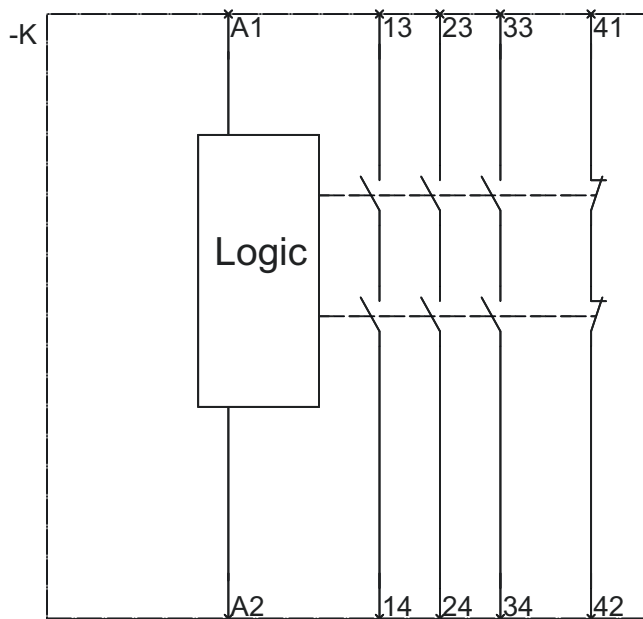

Output expansion 3SK1213-.AB40 (24 V DC)

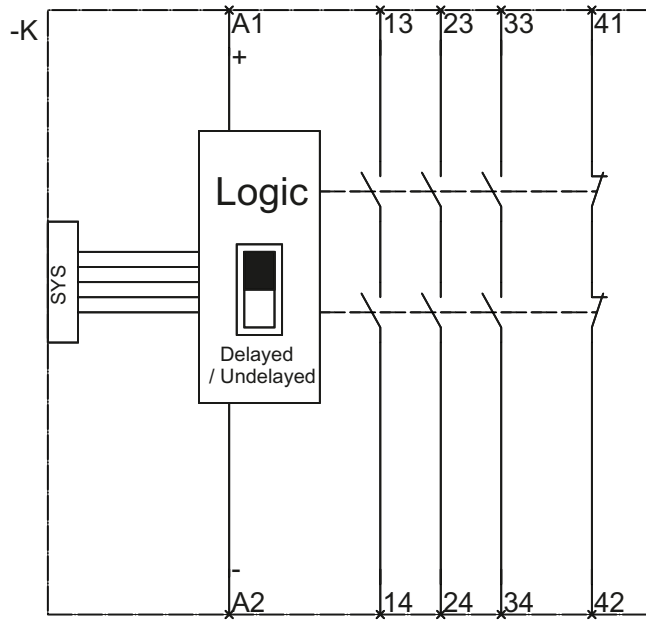

14.3 Typical circuits

The black fields show the positions of the switches. Here, "Autostart" in each case.

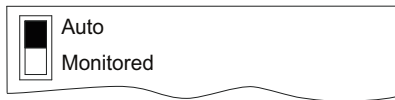

If use of the feedback circuit is not desired for the application, this has to be jumpered with the corresponding test output.

Typical circuit for 3SK1111 Standard relay basic unit

Table 14-1 Typical circuit 1:
Single-channel, with monitored start

<p>* For 3SK1111-..AB30 basic unit only</p>	<ul style="list-style-type: none"> • Monitored start • 3SK1111 Standard relay • Sensor: 1 NC contact 				
	Slide switch				
	<table border="1"> <thead> <tr> <th>Auto</th> <th>Monitored</th> </tr> </thead> <tbody> <tr> <td>—</td> <td>ON Bottom</td> </tr> </tbody> </table>	Auto	Monitored	—	ON Bottom
	Auto	Monitored			
	—	ON Bottom			
Up to PL in accordance with ISO 13849-1	c				
Up to Safety Integrity Level (SILCL) to IEC 62061	1				

Table 14-2 Typical circuit 2:
Single-channel, with monitored start

	<ul style="list-style-type: none"> Monitored start 3SK1111-.AB30 Standard relay Sensor: 1 NC contact 	
	Slide switch	
	Auto	Monitored
	—	ON Bottom
	Up to PL in accordance with ISO 13849-1	c
Up to Safety Integrity Level (SILCL) to IEC 62061	1	

Table 14-3 Typical circuit 3:
single-channel, with autostart

	<ul style="list-style-type: none"> Autostart 3SK1111 Standard relay Sensor: 1 NC contact 	
	Slide switch	
	Auto	Monitored
	ON Top	—
	Up to PL in accordance with ISO 13849-1	c
Up to Safety Integrity Level (SILCL) to IEC 62061	1	

* For 3SK1111-.AB30 basic unit only

14.3 Typical circuits

Table 14-4 Typical circuit 4:
single-channel, with autostart

	<ul style="list-style-type: none"> Autostart 3SK1111-.AB30 Standard relay Sensor: 1 NC contact 						
	Slide switch						
	<table border="1"> <thead> <tr> <th>Auto</th> <th>Monitored</th> </tr> </thead> <tbody> <tr> <td>ON</td> <td>—</td> </tr> <tr> <td>Top</td> <td>—</td> </tr> </tbody> </table>	Auto	Monitored	ON	—	Top	—
	Auto	Monitored					
ON	—						
Top	—						
Up to PL in accordance with ISO 13849-1	c						
Up to Safety Integrity Level (SILCL) to IEC 62061							
1							

Table 14-5 Typical circuit 5:
2-channel EMERGENCY STOP, with cross-circuit detection, with monitored start

	<ul style="list-style-type: none"> Monitored start With cross-circuit detection Sensor: 2 NC contacts 3SK1111 Standard relay 						
	Slide switch						
	<table border="1"> <thead> <tr> <th>Auto</th> <th>Monitored</th> </tr> </thead> <tbody> <tr> <td>—</td> <td>ON</td> </tr> <tr> <td>—</td> <td>Bottom</td> </tr> </tbody> </table>	Auto	Monitored	—	ON	—	Bottom
	Auto	Monitored					
—	ON						
—	Bottom						
Up to PL in accordance with ISO 13849-1	e						
Up to Safety Integrity Level (SILCL) to IEC 62061							
3							

* For 3SK1111-.AB30 basic unit only

When connecting magnetically operated switches as sensors, observe the information in chapter Use of magnetically operated switches (Page 45).

Table 14-6 Typical circuit 6:
Two-channel, with cross-circuit detection, with autostart

<p>* For 3SK1111-.AB30 basic unit only</p>	<ul style="list-style-type: none"> • Autostart • With cross-circuit detection • Sensor: 2 NC contacts • 3SK1111 Standard relay 		
	Slide switch		
	Auto	Monitored	
	ON Top	—	
	Up to PL in accordance with ISO 13849-1	e	
Up to Safety Integrity Level (SILCL) to IEC 62061		3	

14.3 Typical circuits

Table 14-7 Typical circuit 7:
Sensors with solid-state outputs, without cross-circuit detection, with autostart

The diagram shows a control panel with terminals A1 (+), T1, IN1, T2, IN2, T3, IN3, T4, and IN F/S. A slide switch is connected to L+ and the IN F/S terminal. Relays Q1 and Qn are connected to the T1, T2, T3, and T4 terminals. A motor M is connected to the output of the relays. A legend indicates 'Auto' (black) and 'Monitored' (white) states.

- Autostart
- Without cross-circuit detection
- Sensor: 2-channel non-floating
- 3SK1111-.AB30 Standard relay

Slide switch	
Auto	Monitored
ON	—
Top	—
Up to PL in accordance with ISO 13849-1	e
Up to Safety Integrity Level (SILCL) to IEC 62061	3

Typical circuits for 3SK1 Standard solid-state basic units or 3SK1 Advanced basic units

Table 14-8 Typical circuit 8: EMERGENCY STOP two-channel, with cross-circuit detection, with monitored start

	<ul style="list-style-type: none"> • Monitored start • With cross-circuit detection • 1 x two-channel • Sensor: 2 NC contacts • 3SK1112 Standard solid-state and 3SK112 / 3SK122 Advanced 								
	DIP switch								
	<table border="1"> <thead> <tr> <th>1</th> <th>2</th> <th>3</th> <th>4</th> </tr> </thead> <tbody> <tr> <td>ON Right</td> <td>ON Right</td> <td>ON Right</td> <td>—</td> </tr> </tbody> </table>	1	2	3	4	ON Right	ON Right	ON Right	—
	1	2	3	4					
ON Right	ON Right	ON Right	—						
Up to PL in accordance with ISO 13849-1	e								
Up to Safety Integrity Level (SILCL) to IEC 62061	3								

Table 14-9 Typical circuit 9: Two-channel, with cross-circuit detection, with autostart

	<ul style="list-style-type: none"> • Autostart • With cross-circuit detection • 1 x two-channel • Sensor: 2 NC contacts • 3SK1112 Standard solid-state and 3SK112 / 3SK122 Advanced 								
	DIP switch								
	<table border="1"> <thead> <tr> <th>1</th> <th>2</th> <th>3</th> <th>4</th> </tr> </thead> <tbody> <tr> <td>OFF Left</td> <td>ON Right</td> <td>ON Right</td> <td>—</td> </tr> </tbody> </table>	1	2	3	4	OFF Left	ON Right	ON Right	—
	1	2	3	4					
OFF Left	ON Right	ON Right	—						
Up to PL in accordance with ISO 13849-1	e								
Up to Safety Integrity Level (SILCL) to IEC 62061	3								

14.3 Typical circuits

Table 14-10 Typical circuit 10:
Electronic sensor, 2-channel, without cross-circuit detection, with monitored start

DIP switch			
1	2	3	4
ON Right	OFF Left	ON Right	—
Up to PL in accordance with ISO 13849-1			e
Up to Safety Integrity Level (SILCL) to IEC 62061			3

Table 14-11 Typical circuit 11:
Electronic sensor, two-channel, without cross-circuit detection, with autostart

DIP switch			
1	2	3	4
OFF Left	OFF Left	ON Right	—
Up to PL in accordance with ISO 13849-1			e
Up to Safety Integrity Level (SILCL) to IEC 62061			3

Note
Single-channel connection

If only one single-channel sensor is used, the other sensor circuit must be jumpered.

Table 14-12 Typical circuit 12: 2 x single-channel, without cross-circuit detection, with monitored start

	<ul style="list-style-type: none"> • Monitored start • Without cross-circuit detection • 2 x single-channel • Sensor: 2 x single-channel NC sensors • 3SK1112 Standard solid-state and 3SK112 / 3SK122 Advanced <table border="1"> <thead> <tr> <th colspan="4">DIP switch</th> </tr> <tr> <th>1</th> <th>2</th> <th>3</th> <th>4</th> </tr> </thead> <tbody> <tr> <td>ON Right</td> <td>OFF Left</td> <td>OFF Left</td> <td>—</td> </tr> <tr> <td colspan="3">Up to PL in accordance with ISO 13849-1</td> <td>c</td> </tr> <tr> <td colspan="3">Up to Safety Integrity Level (SILCL) to IEC 62061</td> <td>1</td> </tr> </tbody> </table>	DIP switch				1	2	3	4	ON Right	OFF Left	OFF Left	—	Up to PL in accordance with ISO 13849-1			c	Up to Safety Integrity Level (SILCL) to IEC 62061			1
DIP switch																					
1	2	3	4																		
ON Right	OFF Left	OFF Left	—																		
Up to PL in accordance with ISO 13849-1			c																		
Up to Safety Integrity Level (SILCL) to IEC 62061			1																		

14.3 Typical circuits

Table 14-13 Typical circuit 13: 2 x single-channel, without cross-circuit detection, with autostart

	<ul style="list-style-type: none"> • Autostart • Without cross-circuit detection • 2 x single-channel • Sensor: 2 x single-channel NC • 3SK1112 Standard solid-state and 3SK112 / 3SK122 Advanced <table border="1"> <thead> <tr> <th colspan="4">DIP switch</th> </tr> <tr> <th>1</th> <th>2</th> <th>3</th> <th>4</th> </tr> </thead> <tbody> <tr> <td>OFF Left</td> <td>OFF Left</td> <td>OFF Left</td> <td>—</td> </tr> <tr> <td colspan="3">Up to PL in accordance with ISO 13849-1</td> <td>c</td> </tr> <tr> <td colspan="3">Up to Safety Integrity Level (SILCL) to IEC 62061</td> <td>1</td> </tr> </tbody> </table>	DIP switch				1	2	3	4	OFF Left	OFF Left	OFF Left	—	Up to PL in accordance with ISO 13849-1			c	Up to Safety Integrity Level (SILCL) to IEC 62061			1
DIP switch																					
1	2	3	4																		
OFF Left	OFF Left	OFF Left	—																		
Up to PL in accordance with ISO 13849-1			c																		
Up to Safety Integrity Level (SILCL) to IEC 62061			1																		

Also possible: 2 x single-channel with T1-IN1, T2-IN2 and DIP switch 2 cross-circuit detection to ON.

Typical circuits for 3SK1 Advanced basic units only

Table 14-14 Typical circuit 14:
1NC/1NO sensor, with cross-circuit detection, with monitored start

	<ul style="list-style-type: none"> • Monitored start • With cross-circuit detection • 1 x two-channel • Jumper T1/PAR for NC/NO evaluation • Sensor: NC/NO sensor • 3SK112 / 3SK122 Advanced <table border="1"> <thead> <tr> <th colspan="4">DIP switch</th> </tr> <tr> <th>1</th> <th>2</th> <th>3</th> <th>4</th> </tr> </thead> <tbody> <tr> <td>ON Right</td> <td>ON Right</td> <td>ON Right</td> <td>—</td> </tr> <tr> <td colspan="3">Up to PL in accordance with ISO 13849-1</td> <td>e</td> </tr> <tr> <td colspan="3">Up to Safety Integrity Level (SILCL) to IEC 61508</td> <td>3</td> </tr> </tbody> </table>	DIP switch				1	2	3	4	ON Right	ON Right	ON Right	—	Up to PL in accordance with ISO 13849-1			e	Up to Safety Integrity Level (SILCL) to IEC 61508			3
DIP switch																					
1	2	3	4																		
ON Right	ON Right	ON Right	—																		
Up to PL in accordance with ISO 13849-1			e																		
Up to Safety Integrity Level (SILCL) to IEC 61508			3																		

Table 14-15 Typical circuit 15:
1NC/1NO sensor, with cross-circuit detection, with autostart

	<ul style="list-style-type: none"> • Autostart • With cross-circuit detection • 1 x two-channel • Jumper T1/PAR for NC/NO evaluation • Sensor: NC/NO sensor • 3SK112 / 3SK122 Advanced <table border="1"> <thead> <tr> <th colspan="4">DIP switch</th> </tr> <tr> <th>1</th> <th>2</th> <th>3</th> <th>4</th> </tr> </thead> <tbody> <tr> <td>OFF Left</td> <td>ON Right</td> <td>ON Right</td> <td>—</td> </tr> <tr> <td colspan="3">PL in accordance with ISO 13849-1</td> <td>e</td> </tr> <tr> <td colspan="3">Safety Integrity Level (SILCL) to IEC 61508</td> <td>3</td> </tr> </tbody> </table>	DIP switch				1	2	3	4	OFF Left	ON Right	ON Right	—	PL in accordance with ISO 13849-1			e	Safety Integrity Level (SILCL) to IEC 61508			3
DIP switch																					
1	2	3	4																		
OFF Left	ON Right	ON Right	—																		
PL in accordance with ISO 13849-1			e																		
Safety Integrity Level (SILCL) to IEC 61508			3																		

14.3 Typical circuits

Table 14-16 Typical circuit 16:
Two-hand operation with cross-circuit detection, with autostart

DIP switch			
1	2	3	4
OFF Left	ON Right	OFF Left	—
PL in accordance with ISO 13849-1			e
Safety Integrity Level (SILCL) to IEC 61508			3

You can find further information on two-hand operation in chapter Two-hand operation/ synchronism (Page 39).

Table 14-17 Typical circuit diagram 17:
Advanced cascading input with monitored start

DIP switch			
1	2	3	4
ON Right	---	---	—
PL in accordance with ISO 13849-1			e
Safety Integrity Level (SIL) acc. to IEC 62061			3

¹ Safety level PL/SIL of the application always corresponds to the lowest safety level of a subsystem of the application.
Consequently, in order to achieve SIL 3/PL e, the connected sensor must be appropriately qualified via the INK input and an error exclusion (protected laying of the control line) must be applied.

Table 14-18 Typical circuit diagram 18:
Autostart – single-channel via cascading INK input

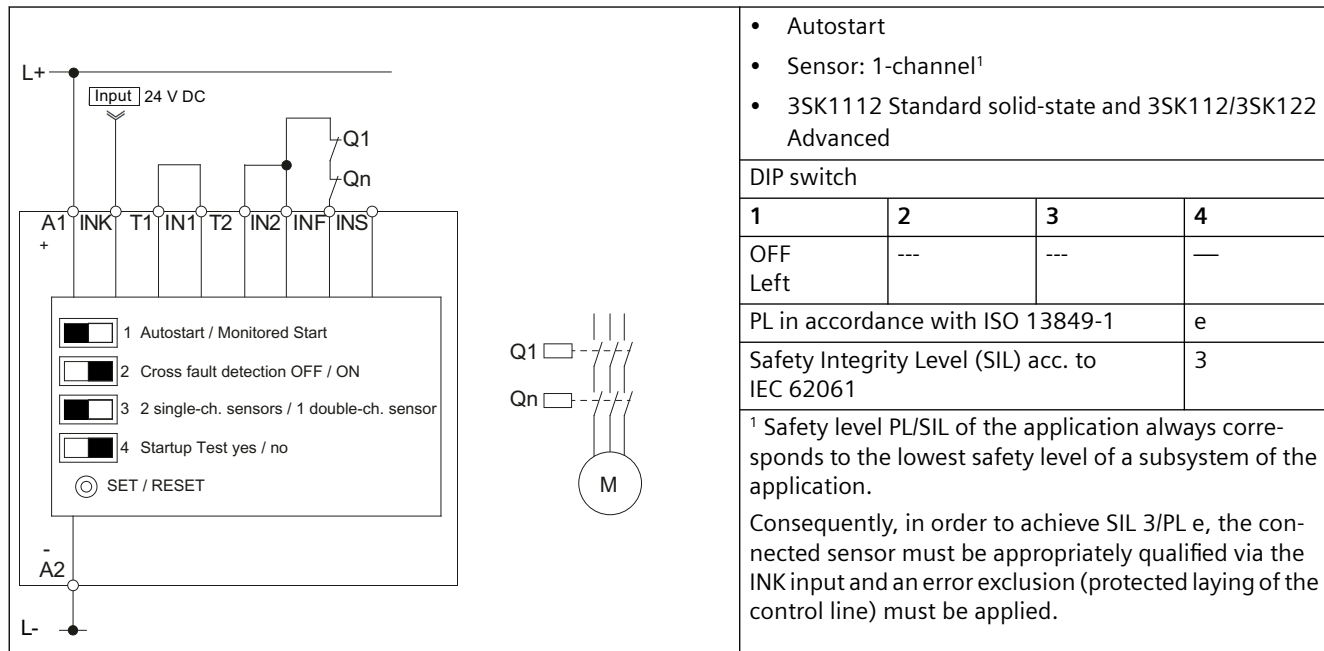

Further information:

- SIRIUS Safety Integrated Application Manual (<https://support.industry.siemens.com/cs/ww/en/view/81366718>)
- FAQs on 3SK1 (<https://support.industry.siemens.com/cs/ww/en/ps/16382/faq>)

Accessories

15.1 Accessories for 3SK1

The following accessories are available for the 3SK1 safety relay system.

Designation	Article number	Image
SIRIUS terminal 2-pole screw-type terminal 2 x 1.5 mm ² or 1 x 2.5 mm ²	3ZY1121-1BA00	 <p>Example 3ZY1121-1BA00</p>
SIRIUS terminal 3-pole screw-type terminal 2 x 1.5 mm ² or 1 x 2.5 mm ²	3ZY1131-1BA00	
SIRIUS terminal 2-pole screw-type terminal 2 x 2.5 mm ² or 1 x 4 mm ²	3ZY1122-1BA00	
SIRIUS spring-loaded terminal (push-in) 2-pole 2 x 1.5 mm ² or 1 x 2.5 mm ²	3ZY1121-2BA00	 <p>Example 3ZY1121-2BA00</p>
SIRIUS spring-loaded terminal (push-in) 3-pole 2 x 1.5 mm ² or 1 x 2.5 mm ²	3ZY1131-2BA00	
SIRIUS spring-loaded terminal (push-in) 2-pole 2 x 2.5 mm ² or 1 x 4 mm ²	3ZY1122-2BA00	

15.1 Accessories for 3SK1

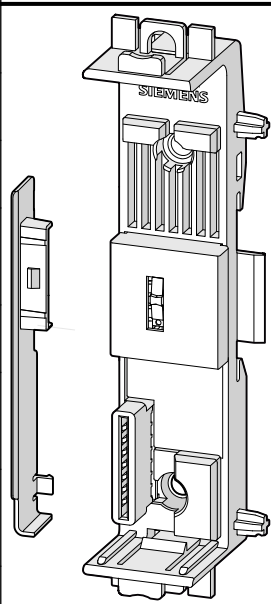
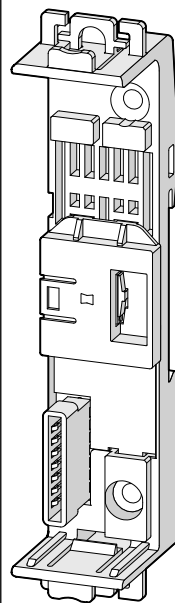
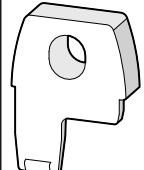
Designation	Article number	Image
SIRIUS device connector for 3SK1 / 3RQ1 safety relay, 17.5 mm wide	3ZY1212-1BA00	
SIRIUS device connector for 3RQ1 safety relay, 17.5 mm wide	3ZY1212-1DA00	
SIRIUS device connector for 3SK1 / 3RQ1 safety relay, 22.5 mm wide	3ZY1212-2BA00	
SIRIUS device termination connector for 3SK1 / 3RQ1 safety relay, 22.5 mm wide	3ZY1212-2DA00	
SIRIUS device connector for 3RM1 motor starters, 22.5 mm wide	3ZY1212-2EA00	
SIRIUS device termination connector for 3RM1 motor starters, 22.5 mm wide	3ZY1212-2FA00	
SIRIUS device termination connector set for 3SK1 safety relay, ≥ 45 mm wide	3ZY1212-0FA01	
SIRIUS device connector for looping through signals, 22.5 mm wide (for 3RM1 motor starters)	3ZY1212-2AB00	
SIRIUS device connector for height compensation without electrical function, 22.5 mm wide	3ZY1210-2AA00	
SIRIUS push-in lugs for wall mounting (Contents: 12 units)	3ZY1311-0AA00	

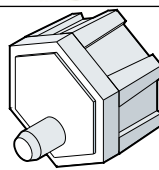
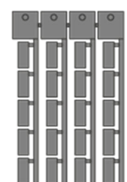
Designation	Article number	Image
SIRIUS sealable cover, 17.5 mm	3ZY1321-1AA00	
SIRIUS sealable cover, 22.5 mm	3ZY1321-2AA00	
Coding pins for SIRIUS terminals	3ZY1440-1AA00	
SIRIUS device identification label 17 sheets of 48 labels; size 10 x 7 mm	3RT2900-1SB10	
SIRIUS device identification label 17 sheets of 20 labels; size 20 x 7 mm	3RT2900-1SB20	
SIRIUS device identification label 10 sheets of 306 adhesive labels; size 19 x 6 mm	3RT2900-1SB60	

Use of removable terminals for 3SK1

The following removable terminals are available for the safety relays for pre-wiring of the terminals in the control cabinet, or for replacing terminals:

3SK1 safety relays	Terminal		
	2-pin	3-pin	2-pin
	3ZY1121-*BA00	3ZY1131-*BA00	3ZY1122-*BA00
3SK1 Advanced basic units			
3SK1111	---	✓	---
3SK1112	✓	---	---
3SK1120	---	✓	---
3SK1121	---	✓	---
3SK1122	✓ bottom	✓ top	---
Output expansions			
3SK1211	✓	---	---
3SK1213	---	---	---
3RQ1	---	---	✓
Input expansions			
3SK1220	---	✓ top	---
3SK1230	✓ bottom	---	---

* - 1 Screw terminal

* - 2 Spring-loaded terminal (push-in)

15.1 Accessories for 3SK1

Device connectors for 3SK112., 3SK12.. and 3SK2

Device connectors can be used to interconnect multiple devices of the 3SK-/3RM-/3RQ1 system. It is not possible to use device connectors with the 3SK1 Standard.

Device connectors are available in different designs specifically for the 3SK safety relays:

For type	Device connector			
	3ZY1212-1BA00-2BA00	3ZY1212-2BA00	3ZY1212-2GA00	3ZY1212-4GA01
	For 3SK1/3RQ1, 17.5 mm wide	For 3SK1/3RQ1, 22.5 mm wide	For 3SK2, 22.5 mm wide	For 3SK2, 45 mm wide
3SK1 Advanced basic units				
3SK1120	✓	--	--	--
3SK1121	--	✓	--	--
3SK1122	--	✓	--	--
3SK2 basic units				
3SK2112	--	--	✓	--
3SK2122	--	--	--	✓
Output expansions				
3SK1211	--	✓	--	--
3SK1213	--	--	--	--
3RQ1 17.5 mm	✓	--	--	--
3RQ, 22.5 mm	--	✓	--	--
Input expansions				
3SK1220	✓	--	--	--
3SK1230	--	✓	--	--

✓ Possible

-- Not possible

For type	Device termination connector		
	3ZY1212-1DA00	3ZY1212-2DA00	3ZY1212-0FA01
	For 3RQ1, 17.5 mm wide	For 3SK1/3RQ1, 22.5 mm wide	For 3SK1, set for enclosures ≥ 45 mm
3SK1 Advanced basic units			
3SK1120	--	--	--
3SK1121	--	✓	--
3SK1122	--	✓	--
3SK2 basic units			
3SK2112	--	--	--
3SK2122	--	--	--
Output expansions			
3SK1211	--	✓	--
3SK1213	--	--	✓
3RQ1 17.5 mm	✓	--	--
3RQ, 22.5 mm	--	✓	--
Input expansions			
3SK1220	--	--	--
3SK1230	--	--	--

✓ Possible

-- Not possible

